



SERVICE BULLETIN

INSTALLATION OF AN ELECTRIC STARTER WITH ENHANCED POWER FOR ROTAX® ENGINE TYPE 912 AND 914 (SERIES) SB-912-037 R1 SB-914-023 R1

OPTIONAL

Repeating symbols:

Please, pay attention to the following symbols throughout this document emphasizing particular information.

▲ **WARNING:** Identifies an instruction, which if not followed, may cause serious injury or even death.

■ **CAUTION:** Denotes an instruction which if not followed, may severely damage the engine or could lead to suspension of warranty.

◆ **NOTE:** Information useful for better handling.

1) Planning information

1.1) Engines affected

All versions of the engine type:

- 912 A from S/N 4,380.600
- 912 F from S/N 4,412.501
- 912 S from S/N 4,922.503
- 914 F from S/N 4,420.001

1.2) Reason

A new starter with enhanced power to improve starting performance has been introduced as an option.

Addition of the electric starter installation requirements.

1.3) Subject

Installation of an electric starter with enhanced power.

1.4) Compliance

OPTIONAL

At owner's discretion, retrofit to enhanced electric starter may be performed in case of start problems (for example: low temperature operations).

1.5) Approval

The technical content of this document is approved under the authority of MOT, DOA Nr. MOT - JA 03.

1.6) Manpower

Estimated man-hours:

engine installed in the aircraft - - - manpower time will depend on installation and therefore no estimate is available from the engine manufacturer.

1.7) Mass data

Change of weight : difference +0.43 kg (0.95 lb).

Moment of inertia - - - unaffected

1.8) Electrical load data

Due to shorter starter operation time, total electrical system load is not affected.

1.9) Software accomplishment summary

No change

d03082

OKTOBER 2003

SB-912-037 R1

SB-914-023 R1

Copyright - ROTAX®

page 1 of 4

1.10) References

In addition to this technical information refer to current issue of

- Operator's Manual (OM)
- Installation Manual (IM)

1.11) Other publications affected

none

1.12) Interchangeability of parts

- All parts are interchangeable

2) Material Information

2.1) Material - cost and availability

Price and availability will be supplied on request by ROTAX[®] Authorized Distributors or their Service Center.

2.2) Material requirement per engine

Parts requirement:

Fig.no.	New p/n	Qty/engine	Description	Old p/n	Application
	889751	1	electric starter set		
consisting of:					
(1)	889750	1	electric starter assy.	293152	
(8)	-	2	allen screw M5x45	941791	
(2)	-	2	lock nut M5	842030	
(3)	-	2	lock washer DIN 128-A5-FST	945750	
(11)	-	2	hex. nut M5 DIN 934	242071	
(4)	-	4	washer 5.3 DIN 125	927571	

2.3) Rework of parts

These parts may be reworked as follows:

Depending on aircraft installation, lugs (A) on the electric starter may be shortened by up to 23 mm (0.91 in) as shown in figure 3.

■ CAUTION: This work shall only be performed by trained personnel and with suitable tools.

3) Accomplishment / Instructions

Accomplishment

All the measures must be taken and confirmed by the following persons or facilities:

- ROTAX[®]-Airworthiness representative
- ROTAX[®]-Distributors or their Service Centers
- Persons approved by the respective Aviation Authority

▲ **WARNING:** Proceed with this work only in a non-smoking area and not close to sparks or open flames. Switch off ignition and secure engine against unintentional operation. Secure aircraft against unauthorized operation. Disconnect negative terminal of aircraft battery.

▲ **WARNING:** Carry out work on a cold engine only.

▲ **WARNING:** Should removal of a locking device (namely lock tabs, self-locking fasteners) be required when undergoing disassembly/assembly, always replace with a new one.

◆ **NOTE:** All work has to be performed in accordance with the relevant Maintenance Manual.

3.1) Removing the electric starter:

(see fig. 1)

Disconnect positive terminal from starter. Remove 2 hex. nuts M5 (2) with lock washers (3) and washers (4) at rear of ignition housing (10). Remove electric starter (1) by loosening securing clamp 76 (7). The electric starter is axially kept in position by 2 spacers (5) and O-rings (6).

◆ **NOTE:** When pulling out the electric starter from the ignition housing, hold together the bearing flange with the starter housing and rotor bearing to prevent the carbon brushes from dislodging from the commutator.

3.2) Installing the electric starter:

(see fig. 2)

Mounting holes for old starter are to be plugged off with 2 Allen screws M5x45 (8), washer (4) and lock nut M5 (2) with 6 Nm (4 in.lb). Clean electric starter mounting surface (9) inside the ignition housing. Slightly lubricate mounting surface (9) with multipurpose grease or engine oil. Slide new electric starter set (1) into ignition housing (10). Tighten electric starter with washer (4), lock washer (3), and hex. nut M5 (11) evenly with 6 Nm (4 in.lb).

■ **CAUTION:** Cyl. screws M5x180 (12) are used for the internal attachment of the starter components. In the course of the mounting of the starter the cyl. screws M5x180 (12) may not be rotated, since it could shift the position of the bearing plate (13) and possibly cause a malfunction of the starter. The markings on the rotor bearing and starter housing must to aligned. (see fig. 4)

◆ **NOTE:** Spacers (5) and the O-rings (6) are not used in this application.

Turn the securing clamp (7) in position and tighten. The clamp is round when new and will form itself around the housing support (14) when tightened. Connect positive terminal to the starter.

- Restore aircraft to original operating configuration.
- Connect negative terminal of aircraft battery.

3.3) Test run

Conduct test run including ignition check and oil leak checks.

3.4) Summary

These instructions (section 3) have to be conducted in compliance with section 1.5.

Approval of translation to best knowledge and judgment - in any case the original text in the German language and the metric units (SI-system) are authoritative.

4) Appendix

the following drawings should convey additional information:

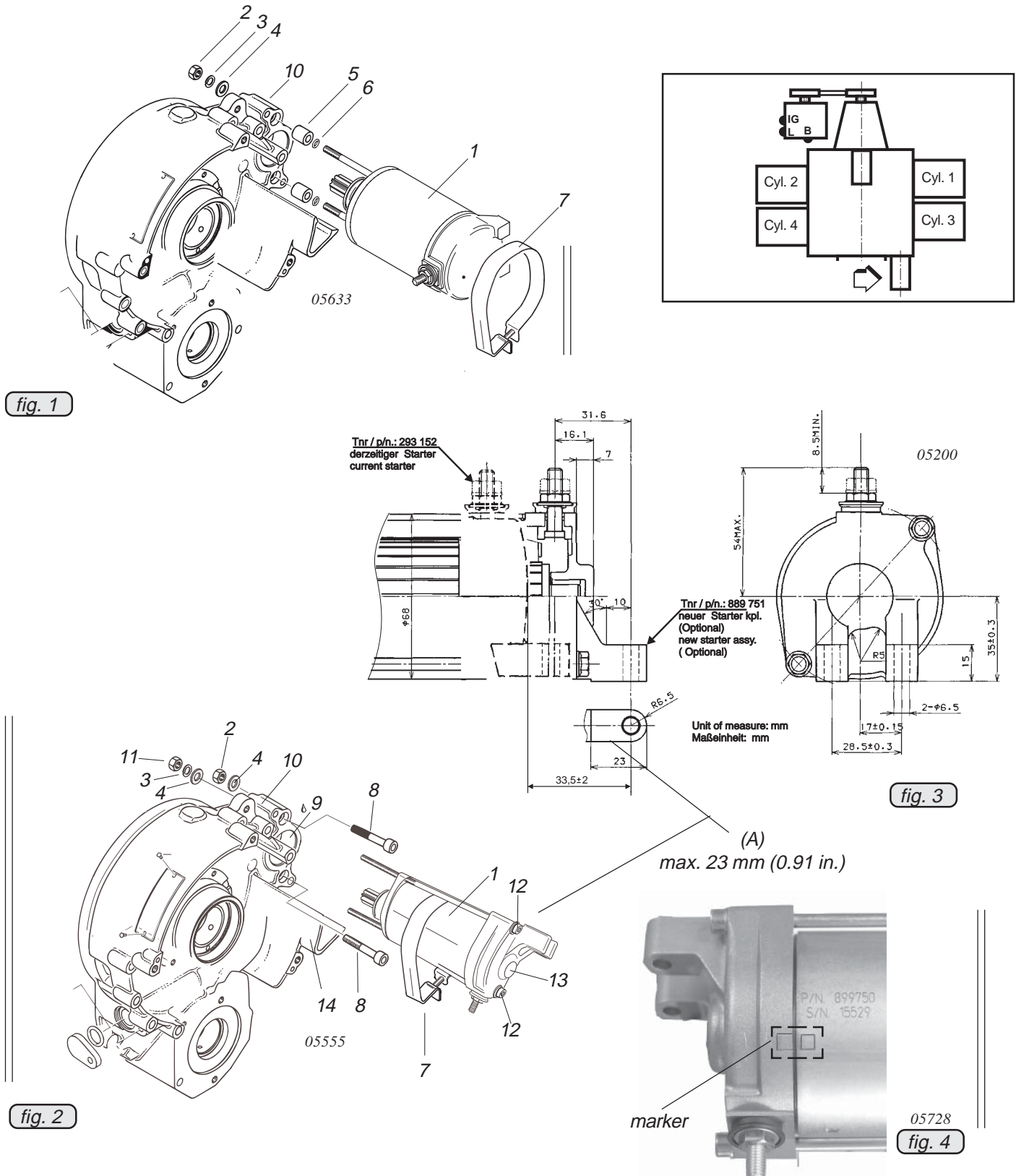

fig. 1

fig. 2

fig. 3

fig. 4

◆ NOTE: The illustrations in this document show the typical construction. They may not represent full detail or the exact shape of the parts which have the same or similar function. Exploded views are **not technical** drawings and are for reference only. For specific detail, refer to the current documents of the respective engine type.