

SERVICE BULLETIN

CHECKING ECCENTERS AND FUEL PUMP PLUNGERS

FOR ROTAX® ENGINE TYPE 912 (SERIES)

SB-912-049UL

MANDATORY

Repeating symbols:

Please, pay attention to the following symbols throughout this document emphasizing particular information.

- ▲ **WARNING:** Identifies an instruction, which if not followed, may cause serious injury or even death.
- **CAUTION:** Denotes an instruction which if not followed, may severely damage the engine or could lead to suspension of warranty.
- ◆ **NOTE:** Information useful for better handling.

1) Planning information

1.1) Engines affected

All versions of the engine type:

- 912 UL from S/N 4,407.200 to S/N 4,407.692
- 912 ULS from S/N 5,644.871 to S/N 5,646.165
- 912 ULSFR from S/N 4,430.123 to S/N 4,430.277

all parts

- Eccenter, part no. 848223, which was supplied as a spare part from April 14, 2005.
- Propellergearbox, S/N 28989 to 31400, which was supplied as a spare part.

Also affected are all engines and gearboxes in which an eccenter part no. 848223 was installed during maintenance, which was supplied as a spare part during the supply period starting April 14, 2005.

For complete instructions and compliance to this Service Bulletin refer to Service Bulletin SB-912-49, latest edition section 1.2 onward.

- ◆ **NOTE:** Section 1.6) Approval: Is not required for engines of the type UL (series).
Section 3) Accomplishment: In addition: persons with adequate type-specific training.

SERVICE BULLETIN

CHECKING ECCENTERS AND FUEL PUMP PLUNGERS FOR ROTAX® ENGINE TYPE 912 (SERIES) SB-912-049

MANDATORY

Repeating symbols:

Please, pay attention to the following symbols throughout this document emphasizing particular information.

▲ **WARNING:** Identifies an instruction, which if not followed, may cause serious injury or even death.

■ **CAUTION:** Denotes an instruction which if not followed, may severely damage the engine or could lead to suspension of warranty.

◆ **NOTE:** Information useful for better handling.

1) Planning information

1.1) Engines affected

All versions of the engine type:

- 912 A from S/N 4,410.661 up to S/N 4,410.685
- 912 F from S/N 4,412.888 up to S/N 4,412.912
- 912 S from S/N 4,923.167 up to S/N 4,923.281

all parts

- Eccenter, part no. 848223, which was supplied as a spare part from April 14, 2005.
- Propellergearbox, S/N 28989 to 31400, which was supplied as a spare part.

Also affected are all engines and gearboxes in which an eccenter part no. 848223 was installed during maintenance, which was supplied as a spare part during the supply period starting April 14, 2005.

1.2) Concurrent ASB/SB/SI and SL

none

1.3) Reason

Because of roughness surface on the eccenter in the propeller gearbox, this can result in abrasion on the fuel pump plunger.

1.4) Subject

Checking eccenters and fuel pump plungers on ROTAX® engine type 912 (Series).

1.5) Compliance

- At the first 25 h maintenance check or at the next 100 h check, but no later than December 31, 2006, the check of the magnetic plug, eccenter and fuel pump plunger must be carried out.

▲ **WARNING:** Non-compliance with these instructions could result in engine damage, personal injury or death!

1.6) Approval

The technical content is approved under the authority of DOA Nr. EASA.21J.048.

1.7) Manpower

Estimated man-hours:

Engine installed in the aircraft - manpower time will depend on installation and thus, no estimate is available from the engine manufacturer.

d03831

1.8) Mass data

Change of weight - none
Moment of inertia - unaffected

1.9) Electrical load data

No change

1.10) Software accomplishment summary

No change

1.11) References

In addition to this technical information refer to current issue of
- Maintenance Manual (MM) of relevant engine type

1.12) Other publications affected

None

1.13) Interchangeability of parts

All used parts which cannot be used must be returned F.O.B. to a ROTAX[®] Authorized Distributors or Service Center.

2) Material Information

2.1) Material - cost and availability

Price and availability will be supplied on request by ROTAX[®] Authorized Distributors or their Service Centers.

2.2) Company support information

None

2.3) Material requirement per engine

Material requirement depends on the necessary work steps:

Item no.	New part no.	Qty. per engine	Description	Old part no.	Application
	XXXXXX*	1	propeller gearbox assy.	xxxxxx*	engine
	845430	1	friction washer VS 30	-	gearbox
	892232*	1	fuel pump assy.	996593*	fuel system
	892236*	1	fuel pump assy. with fuel line	996597*	fuel system
	950225	1	gasket	950220	fuel pump
	950141	1	sealing ring	-	crankshaft locking
	825701	2	oil filter	-	oil pump

* depends on engine type (see IPC)

2.4) Material requirement per spare part

None

2.5) Rework of parts

None

2.6) Special tooling/lubricant-/adhesives-/sealing compound - Price and availability

- Price and availability will be supplied on request by ROTAX[®] Authorized Distributors or their Service Centers.
- Parts requirement: (gearbox disassembly/assembly)

Item no.	New part no.	Qty. per engine	Description	Application
	240880	1	crankshaft locking pin	crankcase
	877660	1	pull-off device	propeller gear
	899784	n.B.	Loctite [®] 574	sealing surface gearbox housing
	898441	n.B.	Loctite [®] 2701	hex. nut M30x1,5 (left-handed thread)
	n.a.*	n.B.	Lapping fleece SR 4600-very fine standard	cleaning

* or equivalent

■ CAUTION: In using these special tools observe the manufacturer's specifications.

3) Accomplishment / Instructions

Accomplishment

All the measures must be taken and confirmed by the following persons or facilities:

- ROTAX[®] -Airworthiness representative
- ROTAX[®] -Distributors or their Service Centers
- Persons approved by the respective Aviation Authority

▲ **WARNING:** Proceed with this work only in a non-smoking area and not close to sparks or open flames. Switch off ignition and secure engine against unintentional operation. Secure aircraft against unauthorized operation. Disconnect negative terminal of aircraft battery.

▲ **WARNING:** Risk of scalds and burns! Allow engine to cool sufficiently and use appropriate safety gear while performing work.

▲ **WARNING:** Should removal of a locking device (namely lock tabs, self-locking fasteners) be required when undergoing disassembly/assembly, always replace with a new one.

3.1) Instructions

(see fig. 1, 2 and 3)

■ **CAUTION:** Conduct all subsequent work in accordance with the current Maintenance Manual of the respective engine type.

- Detailed check of the surface of the fuel pump plunger (see section 3.2).
- Visual inspection of the eccentric for unusual traces of wear (see section 3.2).
- Check magnetic plug (see section 3.2).
- Lock crankshaft if the gearbox must be disassembled.

3.2) Checking fuel pump plunger / eccentric / magnetic plug

- Remove fuel pump
- Detailed check of the surface (2) of the fuel pump plunger (3). The contact surface with the eccentric must have no corrosion. Wear traces that appear slight are permissible. See Fig. 3. The width of the contact area is greater depending on the running time already completed. If traces of wear are visible on the entire diameter of the pump plunger, the fuel pump must be replaced due to too much wear.

◆ **NOTE:** Minimal or usual starting tracks are normal and are not considered.

- Check eccentric through the gearbox opening for unusual wear. Turn the propeller shaft so that the visual inspection can be carried out at several points.

If the surface of the pump plunger and/or eccentric is found to have unusual wear, then the propeller gearbox with drive gear and fuel pump must be sent to the authorized distributor or their service center for repair.

- If OK, then reinstall fuel pump with a new gasket.
- Mount the magnetic plug and check for increased metal content. See Fig. 1.

3.3) Work to be carried out according to current findings for the components

The work is to be carried out according to the following criteria:

Magnetic plug	Pump plungers/eccenter	Instruction (short form)
Layer thickness less than 3 mm (0.12 in.)	not O.K.	Propeller gearbox to distributor - see chapter 3.3.1
Layer thickness greater than 3 mm (0.12 in.)	not O.K.	Propeller gearbox to distributor - see chapter 3.3.2 Inspection of engine
Layer thickness greater than 3 mm (0.12 in.)	O.K.	Inspection according current valid Maintenance Manual Line Maintenance 12-00-00 chapter 5.4)
Layer thickness less than 3 mm (0.12 in.)	O.K.	Reinstall fuelpump with new gasket

08124

3.3.1) Layer thickness less than 3 mm (0.12 in.)

If a quantity of chips (less than 3 mm) is found on the magnetic plug (1) and wear is found on the plunger of the fuel pump, then the eccentric and the fuel pump must be replaced.

The propeller gearbox with drive gear must be sent to the authorized distributor or their service center for repair.

In this case, the drive gear on the crankshaft must also be replaced.

◆ **NOTE:** The drive gear and dog clutch gear are paired and have the same serial number, and must thus be replaced together.

Steel chips in small quantities as shown in Fig. 1 are acceptable as long as the layer thickness is less than 3 mm. If the findings are unclear, the oil circuit must be flushed and a new oil filter installed.

- Carry out a ground run with the new oil filter and check oil filter mats again for chips according to the current maintenance manual. If an unusual quantity of chips is found again, the cause must be found and the damage corrected.

3.3.2) Layer thickness greater than 3 mm (0.12 in.)

If a quantity of chips (greater than 3 mm)(0.12 in) is found on the magnetic plug (1) and wear is found on the plunger of the fuel pump, then the eccentric and the fuel pump must be replaced. The propeller gearbox with drive gear must be sent to the authorized distributor or their service center for repair. The entire engine must be inspected, repaired or overhauled, consistent with the instructions on maintaining airworthiness.

- Remove oil pump, inspect and clean.
- Flush oil circuit.
- Install cleaned oil pump.
- Install new or repaired gearbox.
- Install magnetic plug.
- Install new fuel pump.
- Install new oil filter.
- Loosen crankshaft locking.
- Connect negative terminal of aircraft battery.
- Check all systems for correct function.
- Carry out a ground run with the new oil filter and finally check oil filter mats again for chips according to the current maintenance manual. Check magnetic plug. If an unusual quantity of chips is found again, the cause must be found and the damage corrected.
- Clean magnetic plug and reinstall. Tightening torque 25 Nm (221 in.lb.)
- Lock wire.

3.4) Trial run

Start engine. Conduct test run including ignition check and leakage test in accordance with the current Maintenance Manual of the respective engine type.

3.5) Summary

These instructions (section 3) shall be conducted in accordance with compliance in section 1.5.

Confirm the implementation of the specified Service Bulletin in the Engine Log.

Approval of translation to best knowledge and judgment - in any case the original text in the German language and the metric units (SI-system) are authoritative.

4) Appendix

The following drawings should provide additional information:

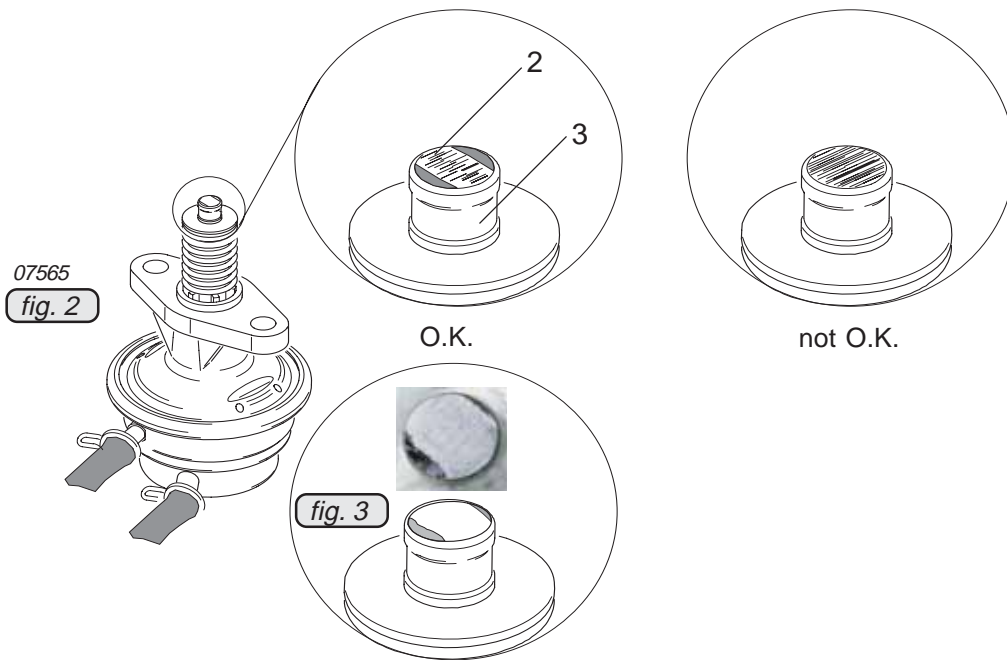
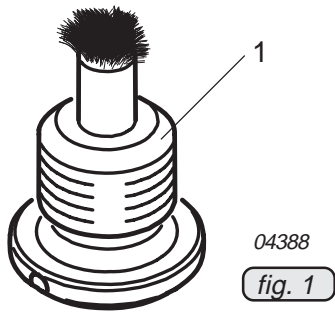

- ◆ NOTE: The illustrations in this document show the typical construction. They may not represent full detail or the exact shape of the parts which have the same or similar function.
Exploded views are **not technical** drawings and are for reference only. For specific detail, refer to the current documents of the respective engine type.