

Inspection and/or replacement of crankcase and/or gearbox housing for ROTAX® engine type 912 i, 915 i and 916 i (Series)

ATA System: 72-00-00 Engine

MANDATORY*

* legally binding after publishing an (E)AD as referenced in EASA CM-21.A-J-001.

1) Planning information

To obtain satisfactory results, procedures specified in this publication must be accomplished with accepted methods in accordance with prevailing legal regulations.

BRP-Rotax GmbH & Co KG cannot accept any responsibility for the quality of work performed in accomplishing the requirements of this publication.

1.1) Applicability

All engines of Series 912 iSc Sport, 915 iSc A, 915 iSc C24, 916 iSc A, 916 iSc C24 and 916 iSc B are affected if at least one of following criteria applies:

Criterion A) Engine S/N:

These engines have been originally delivered from the factory with the possibility of hardness values outside the nominal range:

Engine type	Serial number
912 iSc (Series)	The serial numbers of the affected engine types are mentioned in Chapter 4) Appendix. NOTE: To search for serial numbers, please use the search function (Ctrl+F) in the PDF.
915 iSc (Series)	
916 iSc (Series)	

Criterion B) Spare parts

Further, all engines are affected which have been equipped with the following part no.:

- 893246 OVERHAUL-KIT 912 i (Series) WITH ENGINE BLOCK
- 893249 OVERHAUL-KIT 915 i (Series) WITH ENGINE BLOCK
- 300091210 ENGINE BLOCK 912 i (Series)
- 300091501 ENGINE BLOCK 915 i (Series)
- 811954 GEAR COVER ASSY. 912 i (Series)
- 610362 GEAR COVER ASSY. 912 i (Series)
- 893341 GEARBOX WITH CLUTCH Version 2 912 i (Series)
- 893346 GEARBOX WITH CLUTCH Version 3 912 i (Series)
- 911988 GEARBOX HOUSING ASSY. 915 i / 916 i (Series)
- 686790 GEARSET 2.54 - 3 TORSION SHAFT PACKAGED
- 686810 GEARSET 2,54 - 3 TORSION SHAFT PACKAGED
- 893868 CRANKCASE ASSY. 912 i (Series)

SERVICE BULLETIN

- 886078 CRANKCASE ASSY. 915 i / 916 i (Series)

during engine repair, maintenance or general overhaul, delivered as spare parts from September 1st, 2023 up to November 30th, 2024 included.

1.2) Concurrent ASB/SB/SI and SL

In addition to this Service Bulletin the following documents must be observed:

- SI-912 i-023, SI-912-031, SI-914-032, SI-915 i-009, SI-916 i-009 Change of the Gearbox Configuration for ROTAX Engine Type 916 i, 915 i, 912 i, 912 and 914 (Series)
- SI-912-026, SI-914-027, SI-912 i-012 Important notes for installing the ball bearing into the gearbox of ROTAX Engine Type 912 i, 912 and 914 (Series)
- SI-912 i-001, SI-912-016, SI-914-019, SI-915 i-001, SI-916 i-001 Selection of suitable operating fluids for ROTAX Engine Type 916 i (Series), 915 i (Series), 912 i (Series), 912 and 914 (Series)
- in general, all relevant Alert Service Bulletins (ASB), Service Bulletins (SB), Service Instructions (SI), Service Letters (SL), Service Instruction - Parts and Accessories (SI-PAC) with relevance to perform this maintenance, repair or overhaul task.

1.3) Reason

Due to a deviation in the manufacturing process, engine crankcase and gearbox housing may not reach the correct hardness values. This deviation could possibly lead to reduced endurance of components and/or potential oil leakage.

1.4) Subject

Inspection and/or replacement of crankcase and/or gearbox housing for ROTAX® engine type 912 i, 915 i and 916 i (Series).

1.5) Compliance

- On stored engines / spare parts: prior to delivery.
- On delivered engines / spare parts: before the initial installation, but not later than January 31st 2026.
- On already installed engines (up to 800 hours of operation) / spare parts: at the next scheduled maintenance event carry out this inspection and/or replacement of the crankcase and gearbox housing according to the following instructions in section 3, but at the latest after 1 year (from the date of the initial issue of this Service Bulletin).
- On already installed engines (with more than 800 hours of operation) / spare parts: at the next scheduled maintenance event but at latest within the next 50 hours of operation carry out this inspection and/or replacement of the crankcase and gearbox housing according to the following instructions in section 3, but at the latest after 1 year (from the date of the initial issue of this Service Bulletin).



Non-compliance with these instructions could result in engine damages, personal injuries or death.

1.6) Approval

The technical content of this document is approved under the authority of the DOA ref. EASA.21J.048.

d07185.fm

SERVICE BULLETIN

1.7) Labor time

A labor credit will be provided for work performed by a technician with current applicable iRMT rating.

To apply for labor credit, contact your ROTAX® Authorized Distributor or their independent Service Centers.

1.8) Mass data

Change of weight - - - none

Moment of inertia - - - unaffected

1.9) Electrical load data

No change.

1.10) Software modifications

No change.

1.11) References

In addition to this technical information refer to current issue of

- In general Illustrated Parts Catalog (IPC) and in particular Chapters 72-10-00 & 72-20-00
- In general Operators Manual (OM)
- In general Installation Manual (IM)
- In general Maintenance Manual Line (MML)
- In general Maintenance Manual Heavy (MMH) and in particular Chapters 72-10-00 & 72-20-00

NOTE: The status of the Manuals can be determined by checking the table of amendments. The 1st column of this table shows the revision status. Compare this number to the one listed on the ROTAX® website:

www.flyrotax.com. Updates and current revisions can be downloaded for free.

1.12) Other Publications affected

None

1.13) Interchangeability of parts

None.

SERVICE BULLETIN

2) Material Information

2.1) Material

Price and availability will be provided on request by ROTAX® Authorized Distributors or their independent Service Centers.

2.2) Company support information

- Any possible support by BRP-Rotax will be provided on request by ROTAX® Authorized Distributors or their independent Service Centers
- Exchanged parts must be returned FCA (Free Carrier) and/or proof of scrapping parts must be provided to ROTAX® Authorized Distributors or their independent Service Centers
- This exchange program and cost sharing is valid until January 31st 2026. Up to this date limited reimbursement of costs can be applied for
- Shipping costs, downtime costs, loss of income, telephone costs etc. or costs of conversion to other engine versions or additional work, as for instance simultaneous engine overhauls are not covered in this scope and will not be borne or reimbursed by ROTAX®.

SERVICE BULLETIN

2.3) Material requirement per engine

Parts required for replacement of gearbox housing at 912 i Series, see Fig. 1.

Fig. - pos.	Part no.	Qty/ engine	Description
-	481372	1	REPLACEMENT KIT
consists of:			
1-1	811954	1	GEAR COVER ASSY.
1-2	456520	1	OIL SPRAY NOZZLE ASSY.
1-3	950470	1	OIL SEAL AS 40x55x7 FPM
1-4	832587	1	BALL BEARING 6207 ETN9 C3 35-72-17
1-5	827992	1	THRUST WASHER 33.2/51/1.2
1-6	926035	2	RING HALF
1-7	950141	1	SEALING RING

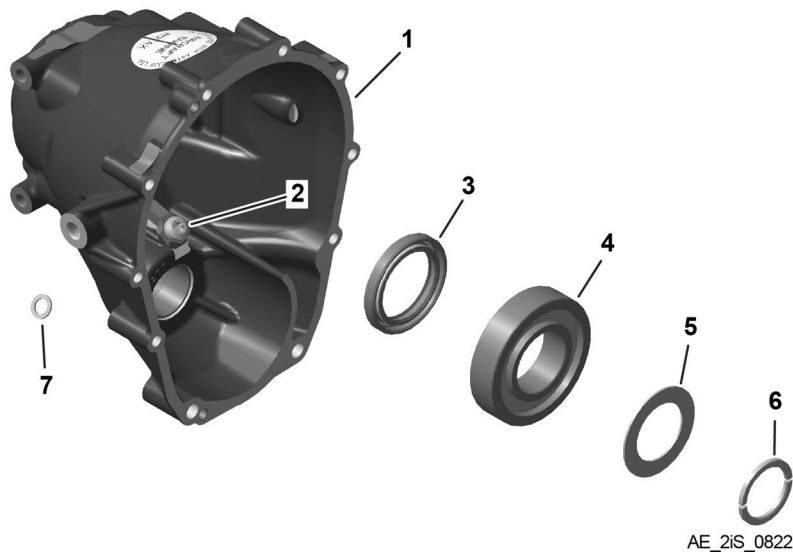

Fig. 1

Gearbox housing with replacement parts (912 i Series)

d07185.fm

SERVICE BULLETIN

Parts required for replacement of gearbox housing at 915 i and 916 i Series, see Fig. 2.

Fig. - pos.	Part no.	Qty/ engine	Description
-	481373	1	REPLACEMENT KIT
consists of:			
2-1	911988	1	GEARBOX HOUSING ASSY.
2-2	250646	1	SEALING RING - A12x18
2-3	230915	1	O-RING - 33x3-N FPM 75
2-4	950091	1	OIL SEAL AS 48x72x8 FKM
2-5	832062	1	BALL BEARING 6208 TN9 C3PAB4F 40-80-18
2-6	950141	1	SEALING RING

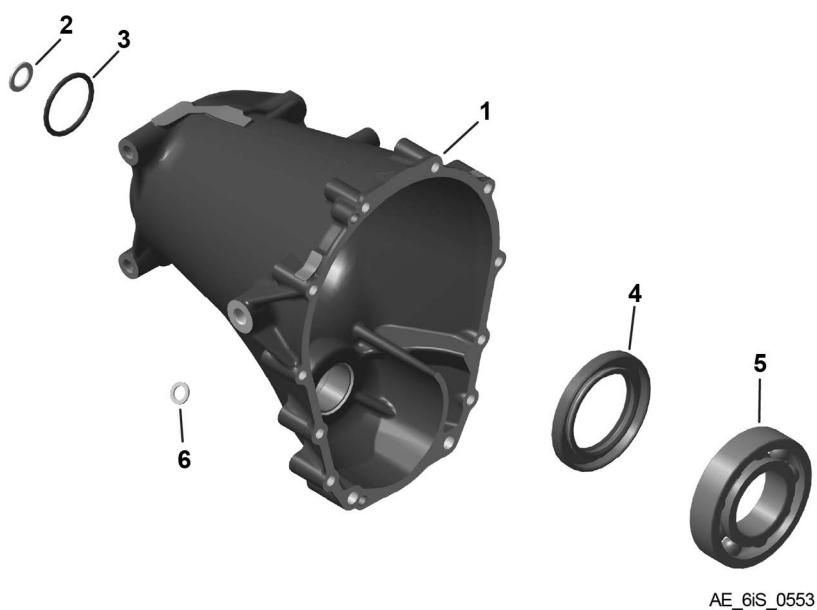

Fig. 2

Gearbox housing with replacement parts (915 i / 916 i Series)

SERVICE BULLETIN

Parts required for replacement of crankcase housing, see Fig. 3:

Part no.	Qty/ engine	Description
300091220	1	ENGINE LONG BLOCK 912 i (Series)
300091510	1	ENGINE LONG BLOCK 915 i (Series)
300091610	1	ENGINE LONG BLOCK 916 i A (Series)
300091611	1	ENGINE LONG BLOCK 916 i B (Series)
-	AR	ENGINE OIL*
-	AR	ENGINE COOLANT*

* See latest SI-912 i-001, SI-912-016, SI-914-019, SI-915 i-001, SI-916 i-001 Selection of suitable operating fluids for ROTAX Engine Type 916 i (Series), 915 i (Series), 912 i (Series), 912 and 914 (Series).

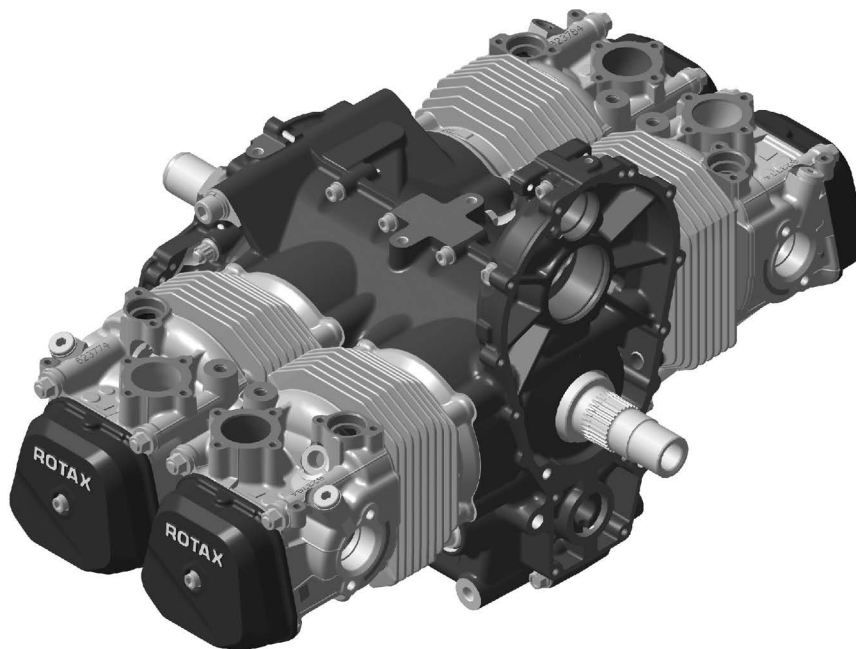

AE_2iS_0817

Fig. 3
TYPICAL - long block (912 i Series shown)

SERVICE BULLETIN

2.4) Special tooling/lubricants- /adhesives- /sealing compounds

See Fig. 4.

Part no.	Description
-	Mitech MH600 Portable leeb hardness tester**
** or equivalent	

NOTICE

If using these special tools observe the manufacturers specifications. All special tools must be calibrated according to the manufacturers specifications.



AE_6iS_0549

Fig. 4
Sample portable hardness tester

SERVICE BULLETIN

3) Accomplishment/Instructions

- ROTAX® reserves the right to make any amendments to existing documents, which might become necessary due to this standardization, at the time of next revision or issue.

NOTE: Before maintenance, review the entire documentation to make sure you have a complete understanding of the procedure and requirements.

Accomplishment

All measures must be implemented and confirmed by at least one of the following persons or organizations:

- ROTAX® - Airworthiness representatives
- ROTAX® - Authorized Distributors or their independent Service Centers
- Persons approved by the respective Aviation Authorities
- Persons with approved qualifications for the corresponding engine types. Only authorized persons (iRMT, Level Line / Heavy Maintenance) are entitled to carry out this work
- Persons with type-specific training

NOTE: Indicates supplementary information which may be needed to fully complete or understand an instruction.



All work has to be performed in accordance with the relevant ROTAX® Instructions for Continued Airworthiness (ICA) of the respective engine type.

General

Further material on general inspection, maintenance and repair can also be found in relevant Advisory Circular AC 43.13 from FAA.

Advisory Circular

The Advisory Circular (AC) contains maintenance methods, techniques and practices.

Procedure

Step	Procedure
1	Check the criteria given on page 1, section 1.1, if the aircraft engine or spare part is affected by this SB.
2	Check the engine logbook and maintenance documentation, if this SB has already been accomplished.

3.1) Illustrated Parts Catalog - related information



See current Illustrated Parts Catalog (IPC) for the respective engine type, Chapters 72-10-00 & 72-20-00.

3.2) Installation - related information



See current Installation Manual (IM) for the respective engine type.

d07185.fm

SERVICE BULLETIN

3.3) Operation - related information



See current Operators Manual (OM) for the respective engine type.
 See also Aircraft Flight Manual (AFM) / Pilot Operating Handbook (POH).

3.4) Maintenance (Line) - related information



See current Maintenance Manual LINE (MML) for the respective engine type.

3.5) Maintenance (Heavy) - related information

3.5.1) Inspection of gearbox housing

NOTE: Only these locations provide reliable results. Other areas have not representative values.

NOTE: All measurements have to be documented and need to be reported to ROTAX® Authorized Distributors or their independent Service Centers for further investigations.

See Fig. 5

Step	Procedure
1	Perform the hardness test 6 times (according to figure 5) on the gearbox housing at the machined surface in each of the areas indicated in Fig. 5. Remove the lowest and highest values and calculate the average of the remaining four measurements (maximum difference of the remaining values allowed: 10 HB). See Fig. 9 for example of how to calculate the resulting hardness value. NOTE: Follow the instructions of the tester manufacturer for calibration, the impact device connection status and direction before performing the hardness test.
2	If the average hardness value is below 87 HB, the gearbox housing must be replaced. Continue to Section 3.5.3).
3	If the average hardness value is 87 HB or higher, the gearbox housing is serviceable. Continue to Section 3.5.2).

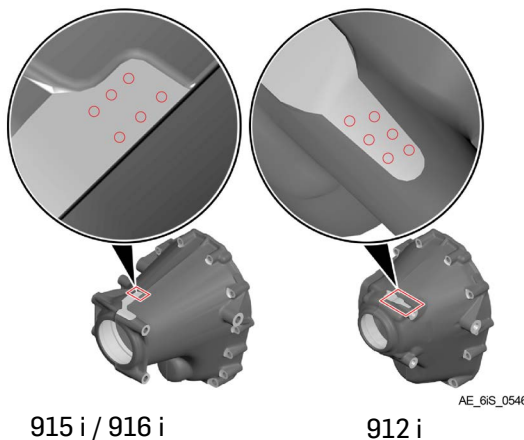

Fig. 5

d07185.fm

SERVICE BULLETIN

3.5.2) Inspection of crankcase

In order to verify the hardness value of the crankcase housing, two options are applicable:

NOTE: Only these locations can be tested to obtain reliable results. Other areas do not give reliable results.

NOTE: The crankcase housings right and left side need both be serviceable in order to be reused; if one is not serviceable, the complete crankcase needs to be replaced.

OPTION A - Crankcase top side:

See Fig. 6

Step	Procedure
1	If equipped, remove the cooling air baffle. See current Maintenance Manual Heavy (MMH) for the respective engine type, Chapter 75-00-00 and SI-PAC-028. NOTE: Before considering to remove the cooling air baffle, first check if option B is possible.
2	Perform the hardness test 6 times on both of the crankcase-halves at the machined surface in each of the areas indicated in Fig. 6. For each crankcase-half remove the lowest and highest values and calculate the average of the remaining four measurements (maximum difference of the remaining values allowed: 10 HB). See Fig. 9 for an example of how to calculate the resulting hardness value. NOTE: Follow the instruction of the tester manufacturer for calibration, the impact device connection status and direction before performing the hardness test
3	If the average hardness value is below 79 HB, the crankcase must be replaced. Continue to Section 3.5.4). Please contact your local Rotax Authorized Distributor or their independent Service Centers to receive further information.
4	If the average hardness value is 79 HB or higher, the crankcase is serviceable. Continue to Section 3.6).

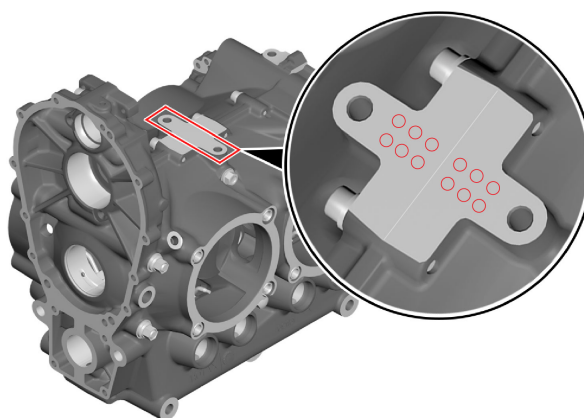

AE_6IS_0547

Fig. 6

d07185.fm

SERVICE BULLETIN

OPTION B - Crankcase bottom side:

See Fig. 7

Step	Procedure
1	<p>Perform the hardness test 6 times on both of the crankcases at the machined surface in each of the areas indicated in Fig. 7. For each crankcase-half remove the lowest and highest values and calculate the average of the remaining four measurements (maximum difference of the remaining values allowed: 10 HB). See Fig. 9 for an example of how to calculate the resulting hardness value.</p> <p>NOTE: Follow the instruction of the tester manufacturer for calibration, the impact device connection status and direction before performing the hardness test.</p>
2	<p>If the average hardness value is below 79 HB, the crankcase must be replaced. Continue to Section 3.5.4).</p> <p>Please contact your local ROTAX Authorized Distributor or their independent Service Centers to receive further information.</p>
3	<p>If the average hardness value is 79 HB or higher, the crankcase is serviceable. Continue to Section 3.6).</p>

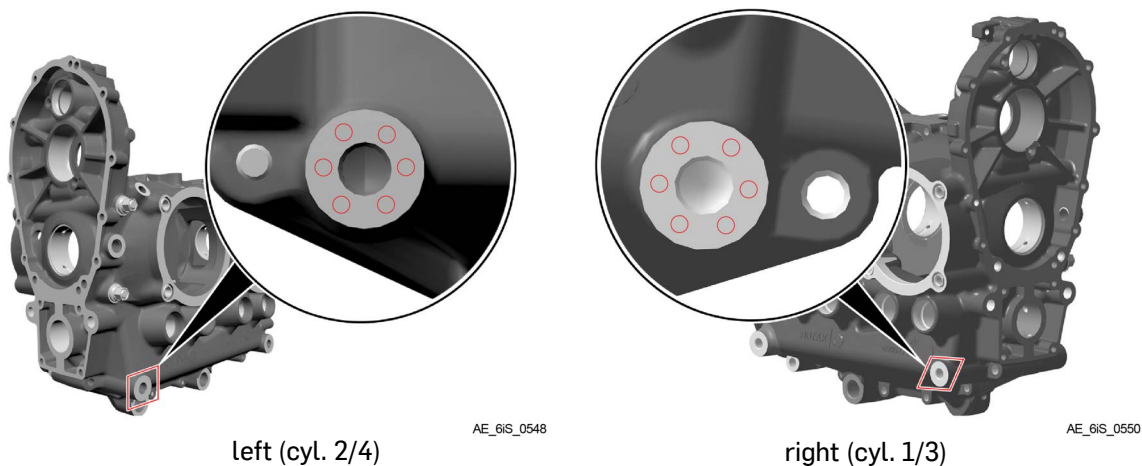

Fig. 7

NOTE: If the lower front engine mounting points have been modified, in anyway, this position can not be used for accurate hardness testing.

d07185.fm

SERVICE BULLETIN

3.5.3) Replacement of gearbox housing

Preparation

Before the propeller gearbox is removed, the work described below must be carried out:

- General visual inspection, see current Maintenance Manual Line (MML) for the respective engine type, Chapter 05-20-00, Section Visual inspection.
- Remove the surrounding assemblies, see current airframe and propeller manufacturer's instructions.
- If installed, remove the gearbox oil line assy, see current Maintenance Manual Heavy (MMH) for the respective engine type, Chapter 61-20-00, Section Removal.
- If installed, remove the external alternator, see current Maintenance Manual Heavy (MMH) for the respective engine type, Chapter 24-30-00, Section Removal.

Step	Procedure
1	Lock the crankshaft. See current Maintenance Manual Line (MML) for the respective engine type, Chapter 12-20-00, section Locking/Loosen of the crankshaft.
2	Remove the gearbox assy. See current Maintenance Manual Line (MML) for the respective engine type, Chapter 05-50-00, section Removal of the propeller gearbox and Drive gear removal. NOTE: Before proceeding with the next steps, perform the crankcase inspection as stated on section 3.5.2).
3	Disassembly the propeller gearbox. See current Maintenance Manual Heavy (MMH) for the respective engine type, Chapter 72-10-00, section Disassembly of the propeller gearbox.
4	Replace gearbox housing and relative parts using the replacement kit part no. 481372 (for 912 i Series), see Fig. 1 or part no. 481373 (for 915 i and 916 i Series), see Fig. 2. Inspect all the remaining parts of the gearbox assy, see current Maintenance Manual Heavy (MMH) for the respective engine type, Chapter 72-10-00, section Inspection and Wear limits. If the parts are not within the given limits or have unusual wear or damage, the components need to be replaced. NOTE: All gaskets, O-rings and oil seals must be replaced! NOTE: Use hand engraver to mark the original gearbox p/n and gearbox s/n on the new gearbox housing dedicated zone.
5	Install the propeller gearbox. See current Maintenance Manual Line (MML) for the respective engine type, Chapter 05-50-00, section Installation of the propeller gearbox.
6	Remove locking pin and install Allen screw with new sealing ring, see current Maintenance Manual Line (MML) for the respective engine type, Chapter 12-20-00, section Locking/Loosen of the crankshaft.
7	Finalize the work as reported in section 3.6).

d07185.fm

SERVICE BULLETIN

3.5.4) Replacement of crankcase

Preparation

Before proceeding with the crankcase removal, be informed that ROTAX® will supply Long Blocks (see section 2.3) for all the engine types affected, in order to facilitate the operation of exchange.

The Long Block contain all the parts assembled of the following systems: displacement parts, valve trains and sprag clutch assy.

Step	Procedure
1	Remove all the systems not included in the Long Block, see current Maintenance Manual Heavy (MMH) for the respective engine type.
2	Remove the engine type plate from the old crankcase and install it on the Long Block (LB), see current Maintenance Manual Heavy (MMH) for the respective engine type. NOTE: The Long Blocks (LB) are already equipped with a dedicated type plate, see Fig. 8. Remove and store this type plate with the engine logbook due to traceability.
3	Inspect all the parts of the systems not included in the Long Block, see current Maintenance Manual Heavy (MMH) for the respective engine type. If the parts are not within given limits or have unusual wear or damage, the components need to be replaced NOTE: All gaskets, O-rings and oil seals must be replaced!
4	Install the systems not included in the Long Block, see current Maintenance Manual Heavy (MMH) for the respective engine type.
5	Finalize the work as reported in section 3.6).

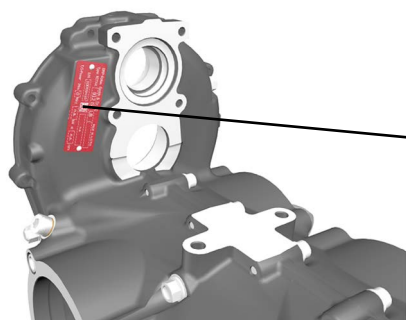

AE_2IS_0818



AE_2IS_0820

TYPICAL
 Fig. 8

d07185.fm

SERVICE BULLETIN

3.6) Finishing work

- Replenish operating fluids or check filling levels, see current Maintenance Manual Line (MML) for the respective engine type, Chapter 12-00-00.
- Purge the oil system, see current Installation Manual (IM) for the respective engine type, Chapter 79-00-00, section Purging the lubrication system.
- Make an entry in the engine logbook stating the execution of this Service Bulletin, the operation performed and the Long Block (LB) serial number (S/N) installed.
- Restore aircraft to original operating configuration.
- Connect negative terminal of aircraft battery.

3.7) Test run

Conduct test run and in case of long block installation perform break-in procedure (including performance check), see latest Overhaul Manual (OHM) of the respective engine type.

In case of uninstalled engines test run is accomplished with the mandatory test run after installation into aircraft.



See Chapter 12-20-00 of the latest Maintenance Manual Line (MML) for the respective engine type.

Perform a leakage check of the whole system, see current Maintenance Manual Line (MML) for the respective engine type.

3.8) Summary

These instructions (section 3) have to be followed in accordance with the deadlines specified in section 1.5.

The execution of the mandatory Service Bulletin must be confirmed in the logbook.

NOTE: Work on EASA certified parts might affect the EASA Form 1 and does require appropriate documentation by authorized persons. Repairs must be entered into the engine logbook and also do apply for the EASA Form 1.

▮ A revision bar outside of the page margin indicates a change to text or graphic.

Translation into other languages might be performed in the course of language localization but does not lie within ROTAX® scope of responsibility.

In any case the original text in English language and the metric units are authoritative.

3.9) Inquiries

Inquiries regarding this Service Bulletin should be sent to the ROTAX® Authorized Distributor of your area.

A list of all ROTAX® Authorized Distributors or their independent Service Centers is provided on <https://dealerlocator.flyrotax.com>.

SERVICE BULLETIN

4) Appendix

NOTE: To get a reliable average value, the minimum and maximum values (called peaks) should not be included in the calculation.

Measurement 1	Measurement 2	Measurement 3	Measurement 4	Measurement 5	Measurement 6
82	80	86	87	83	82
Remove the highest value			87 HB		
Remove the lower value			80 HB		
Measurement 1	Measurement 3	Measurement 5	Measurement 6		
82	86	83	82		
Average			83,25 HB		
Maximum difference			4 HB		
Maximum difference allowed			10 HB		
Gearbox hardness minimum value			87 HB		
Gearbox Not Serviceable					

Fig. 9
 Example of component evaluation (in a spreadsheet editor)

Engine type	Engine S/N
915 iS3 A	10002076
915 iS3 A	10002077
915 iSc3 A	10002147
915 iSc3 A	10002148
915 iSc2 A	10002149
915 iSc2 A	10002150
915 iSc2 A	10002151
915 iSc2 A	10002152
915 iSc2 A	10002153
915 iS3 A	10002174
915 iS3 A	10002175
915 iS3 A	10002176
915 iS3 A	10002177
915 iS3 A	10002178
915 iS3 A	10002179
915 iS2 A	10002180
915 iS2 A	10002181
915 iS2 A	10002182
915 iS2 A	10002183
915 iS2 A	10002184
915 iS2 A	10002185
915 iS2 A	10002186
915 iS2 A	10002187
915 iS2 A	10002188
915 iS2 A	10002189
915 iS3 A	10002282
915 iS3 A	10002283
915 iS3 A	10002284
915 iS3 A	10002285
915 iS3 A	10002286
915 iS2 A	10002287
915 iS2 A	10002288
915 iS2 A	10002289
915 iS2 A	10002290
915 iS2 A	10002291
915 iSc2 A	10002351
915 iSc2 A	10002352
915 iSc2 A	10002353
915 iSc2 A	10002354
915 iSc2 A	10002355
915 iSc2 A	10002356
915 iSc2 A	10002357
915 iSc2 A	10002358
915 iSc2 A	10002359
915 iSc2 A	10002360
915 iS3 A	10002361
915 iS3 A	10002362
915 iS3 A	10002363
915 iS3 A	10002364
915 iS3 A	10002365
915 iS3 A	10002366

Engine type	Engine S/N
915 iS3 A	10002367
915 iS3 A	10002390
915 iS3 A	10002391
915 iS3 A	10002392
915 iS3 A	10002493
915 iS2 A	10002494
915 iS2 A	10002495
915 iS2 A	10002496
915 iS2 A	10002497
915 iS2 A	10002498
915 iS2 A	10002499
915 iS2 A	10002500
915 iS2 A	10002501
915 iS2 A	10002502
915 iS2 A	10002503
915 iS3 A	10002574
915 iS3 A	10002575
915 iS3 A	10002576
915 iS3 A	10002577
915 iS3 A	10002578
915 iS3 A	10002579
915 iS3 A	10002580
915 iS3 A	10002581
915 iS3 A	10002582
915 iS3 A	10002583
915 iS3 A	10002584
915 iS3 A	10002585
915 iS3 A	10002586
915 iS3 A	10002587
915 iSc3 C24	10002606
915 iSc3 C24	10002607
915 iSc3 A	10002608
915 iSc3 A	10002609
915 iS3 A	10002610
915 iS3 A	10002611
915 iS3 A	10002612
915 iS3 A	10002613
915 iS2 A	10002614
915 iS2 A	10002615
915 iS2 A	10002616
915 iS2 A	10002617
915 iS2 A	10002618
915 iSc2 A	10002738
915 iSc2 A	10002739
915 iSc2 A	10002740
915 iSc2 A	10002741
915 iSc2 A	10002742
915 iSc2 A	10002743
915 iSc2 A	10002744
915 iS3 A	10002783
915 iS3 A	10002784
915 iS3 A	10002785
915 iS3 A	10002786
915 iS3 A	10002787

Engine type	Engine S/N
915 iS3 A	10002788
915 iS3 A	10002789
915 iS3 A	10002790
915 iS2 A	10002791
915 iS2 A	10002792
915 iS2 A	10002793
915 iS2 A	10002794
915 iS2 A	10002795
915 iS2 A	10002796
915 iS2 A	10002797
915 iS2 A	10002798
915 iS2 A	10002799
915 iS2 A	10002800
912 iS2 Sport	10002835
912 iS3 Sport	10002836
912 iS3 Sport	10002837
912 iS3 Sport	10002838
912 iS3 Sport	10002839
912 iS3 Sport	10002840
912 iS3 Sport	10002841
912 iS3 Sport	10002842
912 iS3 Sport	10002843
915 iSc2 A	10002883
915 iSc2 A	10002884
915 iSc2 A	10002885
915 iSc2 A	10002886
915 iSc2 A	10002887
915 iSc2 A	10002888
915 iSc2 A	10002889
915 iSc2 A	10002890
916 iS3 A	10002891
916 iS3 A	10002892
916 iS3 A	10002893
916 iS3 A	10002894
915 iS3 A	10002914
915 iS3 A	10002915
915 iS3 A	10002916
915 iS3 A	10002917
915 iS3 A	10002918
915 iS3 A	10002919
915 iS3 A	10002920
915 iS3 A	10002921
915 iS3 A	10002922
915 iS3 A	10002923
915 iS3 A	10002924
915 iS3 A	10002925
915 iS3 A	10002926
915 iS3 A	10002927
915 iS3 A	10002928
915 iS3 A	10002929
915 iS3 A	10002930
915 iS3 A	10002931
915 iS3 A	10002932
915 iS3 A	10002933

Engine type	Engine S/N
912 iS3 Sport	10002995
912 iS3 Sport	10002996
912 iS3 Sport	10002997
912 iS3 Sport	10002998
912 iS3 Sport	10002999
912 iS3 Sport	10003000
912 iSc3 Sport	10003040
912 iSc3 Sport	10003041
912 iSc3 Sport	10003042
912 iSc3 Sport	10003043
912 iSc3 Sport	10003044
912 iSc3 Sport	10003045
915 iSc2 A	10003046
915 iSc2 A	10003047
915 iSc2 A	10003048
915 iSc2 A	10003049
915 iSc2 A	10003050
916 iSc2 A	10003051
916 iSc2 A	10003052
916 iSc2 A	10003053
916 iSc2 A	10003054
916 iSc2 A	10003055
916 iS3 A	10003056
916 iS3 A	10003057
916 iS3 A	10003058
916 iS3 A	10003059
916 iS3 A	10003060
916 iS3 A	10003061
916 iS2 A	10003062
916 iS2 A	10003063
916 iS2 A	10003064
916 iS2 A	10003065
916 iS2 A	10003066
912 iS2 Sport	10003082
912 iS2 Sport	10003083
912 iS2 Sport	10003084
912 iS2 Sport	10003085
912 iS2 Sport	10003086
912 iS3 Sport	10003087
912 iS3 Sport	10003088
912 iS3 Sport	10003089
912 iS3 Sport	10003090
912 iS3 Sport	10003091
912 iS3 Sport	10003092
912 iS3 Sport	10003093
912 iS3 Sport	10003094
912 iS3 Sport	10003095
912 iS3 Sport	10003096
912 iS2 Sport	10003097
912 iS2 Sport	10003098
912 iS2 Sport	10003099
912 iS2 Sport	10003100
912 iS2 Sport	10003101
912 iS3 Sport	10003102

Engine type	Engine S/N
912 iS3 Sport	10003103
912 iS3 Sport	10003104
912 iS3 Sport	10003105
912 iS3 Sport	10003106
912 iS3 Sport	10003107
912 iS3 Sport	10003108
912 iS3 Sport	10003109
912 iS3 Sport	10003110
912 iS3 Sport	10003111
912 iS3 Sport	10003112
912 iS3 Sport	10003113
912 iS3 Sport	10003114
912 iS3 Sport	10003115
912 iS3 Sport	10003116
912 iS3 Sport	10003157
912 iS3 Sport	10003158
912 iS2 Sport	10003159
912 iS2 Sport	10003160
912 iS2 Sport	10003161
912 iS2 Sport	10003162
912 iS2 Sport	10003163
912 iS2 Sport	10003164
912 iS2 Sport	10003165
912 iS2 Sport	10003166
912 iS2 Sport	10003167
912 iS2 Sport	10003168
912 iS2 Sport	10003169
912 iS2 Sport	10003170
912 iS2 Sport	10003171
912 iS2 Sport	10003172
912 iS2 Sport	10003173
912 iS2 Sport	10003174
915 iS3 A	10003175
915 iS3 A	10003176
915 iS3 A	10003177
915 iS3 A	10003178
915 iS3 A	10003179
915 iS3 A	10003180
915 iS3 A	10003181
915 iS3 A	10003182
915 iS3 A	10003183
912 iS3 Sport	10003184
912 iS3 Sport	10003185
912 iS3 Sport	10003186
912 iS3 Sport	10003187
912 iS3 Sport	10003188
912 iS3 Sport	10003189
912 iS3 Sport	10003190
912 iS3 Sport	10003191
912 iS3 Sport	10003192
912 iS3 Sport	10003193
912 iS3 Sport	10003194
912 iS3 Sport	10003195
912 iS3 Sport	10003196

Engine type	Engine S/N
912 iS3 Sport	10003197
912 iS3 Sport	10003198
912 iS3 Sport	10003199
912 iS3 Sport	10003200
912 iS3 Sport	10003201
912 iS3 Sport	10003202
912 iS3 Sport	10003203
912 iS3 Sport	10003204
912 iS3 Sport	10003205
912 iS3 Sport	10003206
912 iS3 Sport	10003207
912 iS3 Sport	10003208
915 iSc2 A	10003315
915 iSc2 A	10003316
915 iSc2 A	10003317
915 iSc2 A	10003318
915 iSc2 A	10003319
915 iSc2 A	10003320
915 iSc2 A	10003321
915 iSc2 A	10003322
915 iSc2 A	10003323
915 iSc2 A	10003324
915 iSc2 A	10003325
915 iSc2 A	10003326
915 iS3 A	10003549
915 iS2 A	10003550
915 iS3 A	10003551
915 iS3 A	10003552
915 iS2 A	10003553
915 iS2 A	10003554
915 iS2 A	10003555
915 iS2 A	10003556
915 iS2 A	10003557
916 iS3 A	10003558
916 iS3 A	10003559
916 iS2 A	10003560
916 iS2 A	10003561
916 iS2 A	10003562
916 iS2 A	10003563
916 iS2 A	10003564
916 iS3 A	10003565
916 iS3 A	10003566
916 iS3 A	10003567
916 iS3 A	10003568
916 iS3 A	10003569
916 iSc3 A	10003673
916 iS3 A	10003674
916 iS3 A	10003675
916 iS3 A	10003676
916 iS3 A	10003677
916 iS3 A	10003678
916 iS3 A	10003679
916 iS3 A	10003680
915 iS3 A	10003706

Engine type	Engine S/N
915 iS3 A	10003707
915 iS2 A	10003708
915 iS2 A	10003709
915 iS2 A	10003710
915 iS2 A	10003711
915 iS2 A	10003712
915 iS2 A	10003713
915 iS2 A	10003714
915 iS2 A	10003715
915 iS2 A	10003716
915 iS2 A	10003717
915 iSc2 A	10003773
915 iSc2 A	10003774
915 iSc2 A	10003775
915 iSc2 A	10003776
915 iSc2 A	10003777
915 iSc3 A	10003778
915 iSc3 A	10003779
915 iSc3 A	10003780
915 iSc3 A	10003781
915 iSc3 A	10003782
915 iSc3 A	10003783
915 iSc3 A	10003784
915 iSc3 A	10003785
915 iSc3 A	10003786
915 iSc3 A	10003787
915 iSc3 A	10003788
915 iS3 A	10003789
916 iS2 A	10003791
916 iS2 A	10003792
916 iS2 A	10003793
916 iS2 A	10003794
915 iSc2 A	10003819
915 iSc2 A	10003820
915 iSc2 A	10003821
915 iSc2 A	10003822
916 iSc2 A	10003823
916 iSc2 A	10003824
916 iSc2 A	10003825
916 iSc2 A	10003826
916 iSc2 A	10003827
916 iS3 A	10003861
916 iS3 A	10003862
915 iS3 A	10003863
915 iS3 A	10003864
915 iS3 A	10003865
915 iS3 A	10003866
915 iS3 A	10003867
915 iS3 A	10003868
915 iS3 A	10003869
915 iS3 A	10003870
915 iS3 A	10003871
915 iS3 A	10003872
915 iS3 A	10003873

Engine type	Engine S/N
915 iS3 A	10003874
915 iS3 A	10003875
915 iS3 A	10003876
915 iS3 A	10003907
915 iS3 A	10003908
915 iS3 A	10003909
915 iS3 A	10003910
915 iS3 A	10003911
915 iS3 A	10003912
915 iS3 A	10003913
915 iS3 A	10003914
915 iS3 A	10003915
915 iS3 A	10003916
916 iS3 A	10003970
916 iS3 A	10003971
916 iS3 A	10003972
916 iS3 A	10003973
916 iS3 A	10003974
916 iS3 A	10003975
916 iS3 A	10003976
916 iS3 A	10003977
915 iSc2 A	10004080
915 iSc2 A	10004081
915 iSc2 A	10004082
915 iSc2 A	10004083
915 iSc2 A	10004084
915 iSc2 A	10004085
916 iS2 A	10004086
915 iSc2 A	10004184
915 iSc2 A	10004185
915 iS3 A	10004186
915 iS2 A	10004187
915 iS2 A	10004188
915 iS2 A	10004189
915 iS2 A	10004190
915 iS3 C24	10004191
916 iS2 A	10004192
916 iS2 A	10004193
916 iS2 A	10004194
916 iS2 A	10004195
916 iS3 A	10004196
916 iS3 A	10004294
916 iS3 A	10004295
916 iS3 A	10004296
916 iS3 A	10004297
916 iS2 A	10004298
916 iS2 A	10004299
916 iS2 A	10004300
916 iS2 A	10004301
916 iS2 A	10004302
915 iS3 A	10004303
915 iS3 A	10004304
915 iS3 A	10004305
915 iS3 A	10004306

Engine type	Engine S/N
915 iS3 A	10004308
915 iS3 A	10004309
915 iS3 A	10004310
915 iS3 A	10004311
915 iS3 A	10004312
915 iS3 A	10004313
915 iS3 A	10004314
915 iS3 A	10004315
915 iS3 A	10004316
915 iS3 A	10004317
915 iS2 A	10004387
915 iS2 A	10004388
915 iS2 A	10004389
915 iS2 A	10004390
915 iS2 A	10004391
915 iS2 A	10004392
915 iS2 A	10004393
915 iS2 A	10004394
915 iS2 A	10004395
915 iS2 A	10004396
915 iS3 A	10004397
915 iS3 A	10004398
915 iS3 A	10004399
915 iSc3 A	10004420
915 iSc3 A	10004421
915 iSc2 A	10004422
915 iSc2 A	10004423
915 iSc2 A	10004424
915 iSc2 A	10004425
915 iSc2 A	10004426
915 iS3 A	10004427
915 iS3 A	10004428
915 iS3 A	10004429
915 iS3 A	10004430
915 iS3 A	10004431
915 iS3 A	10004432
915 iS3 A	10004433
915 iS3 A	10004434
915 iS3 A	10004435
915 iS3 A	10004436
915 iS3 A	10004437
915 iS3 A	10004438
915 iS3 A	10004439
915 iSc2 A	10004527
915 iSc2 A	10004528
915 iSc2 A	10004529
915 iSc2 A	10004530
915 iSc2 A	10004531
915 iSc2 A	10004532
915 iS3 A	10004533
915 iS3 A	10004534
915 iS3 A	10004535
915 iS3 A	10004536
916 iS3 A	10004537

Engine type	Engine S/N
916 iS3 A	10004538
916 iS3 A	10004539
916 iS3 A	10004540
916 iS3 A	10004541
916 iS3 A	10004542
916 iS3 A	10004543
916 iS3 A	10004544
916 iS3 A	10004545
915 iSc3 A	10004626
915 iSc3 A	10004627
915 iSc2 A	10004628
915 iSc2 A	10004629
915 iSc2 A	10004630
915 iSc2 A	10004631
915 iSc2 A	10004632
915 iSc2 A	10004633
915 iSc2 A	10004634
915 iSc2 A	10004635
915 iSc2 A	10004636
915 iS2 A	10004652
915 iS3 A	10004653
915 iS3 A	10004654
915 iS3 A	10004655
915 iS3 A	10004656
915 iS3 A	10004657
915 iS3 A	10004658
915 iS3 A	10004659
916 iSc3 A	10004660
916 iS3 A	10004661
916 iS3 A	10004662
916 iS3 A	10004663
916 iS3 A	10004664
916 iS3 A	10004665
915 iS2 A	10004711
915 iS2 A	10004712
915 iS2 A	10004713
915 iS2 A	10004714
915 iS2 A	10004715
915 iS2 A	10004716
915 iS2 A	10004717
915 iS2 A	10004718
915 iS2 A	10004719
915 iS2 A	10004720
916 iSc2 A	10004721
916 iSc2 A	10004722
916 iSc2 A	10004723
916 iSc2 A	10004724
916 iSc2 A	10004725
916 iSc2 A	10004726
916 iSc2 A	10004727
916 iSc2 A	10004728
916 iSc2 A	10004729
916 iSc2 A	10004730
916 iS3 A	10004758

Engine type	Engine S/N
916 iS3 A	10004759
916 iS3 A	10004760
916 iS3 A	10004761
916 iS2 A	10004762
916 iS2 A	10004763
916 iS2 A	10004764
916 iS2 A	10004765
916 iS2 A	10004766
916 iS2 A	10004767
916 iS2 A	10004768
916 iS2 A	10004769
916 iS2 A	10004770
916 iS2 A	10004771
915 iS3 A	10004820
915 iS3 A	10004821
915 iS3 A	10004822
915 iS3 A	10004823
915 iS3 A	10004824
915 iS2 A	10004825
915 iS2 A	10004826
915 iS2 A	10004827
915 iS2 A	10004828
915 iS2 A	10004829
916 iS3 A	10004830
916 iS3 A	10004831
916 iS3 A	10004832
916 iS3 A	10004833
916 iS3 A	10004834
916 iS3 A	10004835
915 iSc2 A	10004857
915 iSc2 A	10004858
915 iSc2 A	10004859
915 iSc2 A	10004860
915 iSc2 A	10004861
915 iSc2 A	10004862
915 iSc2 A	10004863
915 iSc2 A	10004864
915 iSc2 A	10004865
915 iSc2 A	10004866
915 iSc3 A	10004867
915 iSc3 A	10004868
915 iSc3 A	10004869
915 iSc3 A	10004870
915 iSc3 A	10004871
915 iSc3 A	10004872
916 iS2 A	10004873
916 iS2 A	10004874
916 iS2 A	10004875
915 iSc2 A	10004950
915 iSc2 A	10004951
915 iSc2 A	10004952
915 iSc2 A	10004953
915 iS3 A	10004954
915 iS3 A	10004955

Engine type	Engine S/N
915 iS3 A	10004956
915 iS3 A	10004957
915 iS3 A	10004958
915 iS3 A	10004959
915 iS2 A	10004960
915 iS2 A	10004961
915 iS2 A	10004962
915 iS2 A	10004963
915 iS2 A	10004964
915 iS3 A	10005014
915 iS2 A	10005015
915 iS2 A	10005016
915 iS2 A	10005017
915 iS2 A	10005018
915 iS2 A	10005019
915 iS3 A	10005020
915 iS3 A	10005021
915 iS3 A	10005022
915 iS3 A	10005023
915 iS3 A	10005024
915 iS3 A	10005025
915 iS3 A	10005026
915 iS3 A	10005027
915 iS3 A	10005028
915 iS3 A	10005029
916 iS2 A	10005040
916 iS2 A	10005041
916 iS2 A	10005042
916 iS2 A	10005043
916 iS2 A	10005044
916 iS2 A	10005045
916 iS2 A	10005046
916 iS2 A	10005047
916 iS2 A	10005048
916 iS3 A	10005049
916 iS3 A	10005050
916 iS3 A	10005051
916 iS3 A	10005063
916 iS3 A	10005064
916 iS2 A	10005065
916 iS2 A	10005066
916 iS2 A	10005067
916 iS2 A	10005068
916 iS2 A	10005069
916 iS3 A	10005070
916 iS3 A	10005071
916 iS3 A	10005072
916 iS3 A	10005073
916 iS3 A	10005074
916 iS3 A	10005083
916 iS3 A	10005084
916 iS3 A	10005085
916 iS3 A	10005086
916 iSc3 B	10005087

Engine type	Engine S/N
916 iSc3 B	10005088
916 iSc3 B	10005089
916 iSc3 B	10005090
916 iSc3 B	10005091
912 iSc3 Sport	10005103
912 iSc3 Sport	10005104
912 iSc3 Sport	10005105
912 iSc3 Sport	10005106
912 iSc3 Sport	10005107
912 iSc3 Sport	10005108
912 iSc3 Sport	10005109
912 iSc3 Sport	10005110
912 iSc3 Sport	10005111
912 iSc3 Sport	10005112
912 iSc3 Sport	10005113
912 iSc3 Sport	10005114
912 iSc3 Sport	10005115
915 iS2 A	10005152
915 iS2 A	10005153
915 iS2 A	10005154
915 iS2 A	10005155
915 iS2 A	10005156
915 iS2 A	10005157
915 iS2 A	10005158
915 iS2 A	10005159
915 iS2 A	10005160
915 iS2 A	10005161
915 iS2 A	10005174
915 iS2 A	10005175
915 iS2 A	10005176
915 iS2 A	10005177
915 iS2 A	10005178
915 iS2 A	10005179
915 iS2 A	10005180
915 iS2 A	10005181
915 iS2 A	10005182
915 iS2 A	10005183
915 iS2 A	10005198
915 iS2 A	10005199
915 iS2 A	10005200
915 iS2 A	10005201
915 iS2 A	10005202
915 iS2 A	10005203
915 iS2 A	10005204
915 iS2 A	10005205
915 iS2 A	10005206
915 iS2 A	10005207
915 iSc2 A	10005267
915 iSc2 A	10005268
915 iSc2 A	10005269
915 iS3 A	10005270
915 iS3 A	10005271
915 iS3 A	10005272
915 iS3 A	10005273

Engine type	Engine S/N
915 iS3 A	10005274
915 iS3 A	10005289
915 iS3 A	10005290
915 iS3 A	10005291
915 iS3 A	10005292
915 iS3 A	10005293
915 iS3 A	10005294
915 iS3 A	10005295
915 iS3 A	10005296
915 iS3 A	10005297
915 iS3 A	10005298
915 iS3 A	10005299
915 iS3 A	10005300
912 iS2 Sport	10005308
912 iS2 Sport	10005310
912 iS2 Sport	10005311
912 iS2 Sport	10005312
915 iS3 A	10005313
915 iS3 A	10005314
915 iS3 A	10005315
915 iS3 A	10005316
915 iS2 A	10005317
915 iS2 A	10005318
915 iS2 A	10005319
915 iS2 A	10005320
915 iS2 A	10005321
912 iS3 Sport	10005322
912 iS3 Sport	10005323
912 iS3 Sport	10005324
912 iS3 Sport	10005325
912 iS3 Sport	10005326
912 iS3 Sport	10005327
912 iS3 Sport	10005328
912 iS3 Sport	10005329
912 iS3 Sport	10005330
912 iS3 Sport	10005331
912 iS3 Sport	10005332
912 iS3 Sport	10005333
912 iS3 Sport	10005334
912 iS3 Sport	10005335
912 iS3 Sport	10005336
912 iS2 Sport	10005337
912 iS2 Sport	10005338
912 iS2 Sport	10005339
912 iS2 Sport	10005340
912 iS2 Sport	10005341
912 iS3 Sport	10005342
912 iS3 Sport	10005343
912 iS3 Sport	10005344
912 iS3 Sport	10005345
912 iS3 Sport	10005346
912 iS2 Sport	10005347
912 iS2 Sport	10005348
912 iS2 Sport	10005349

Engine type	Engine S/N
912 iS2 Sport	10005350
912 iS2 Sport	10005351
912 iS2 Sport	10005352
912 iS2 Sport	10005353
912 iS2 Sport	10005354
912 iS2 Sport	10005355
912 iS2 Sport	10005356
915 iSc3 A	10005357
915 iSc3 A	10005358
915 iSc2 A	10005359
915 iSc2 A	10005360
915 iSc2 A	10005361
915 iSc2 A	10005362
915 iSc2 A	10005363
915 iSc2 A	10005364
915 iSc2 A	10005365
915 iSc2 A	10005366
915 iSc2 A	10005367
915 iSc2 A	10005368
915 iS3 A	10005380
915 iS3 A	10005381
915 iS3 A	10005382
915 iS3 A	10005383
915 iS3 A	10005384
915 iS3 A	10005385
915 iS3 A	10005386
915 iS3 A	10005387
915 iS3 A	10005388
915 iS3 A	10005389
915 iS3 A	10005390
916 iSc3 A	10005405
916 iS2 A	10005406
916 iS2 A	10005407
916 iS2 A	10005408
916 iS2 A	10005409
916 iS2 A	10005410
916 iS3 A	10005411
916 iS3 A	10005412
916 iS3 A	10005413
916 iS3 A	10005414
916 iS3 A	10005415
916 iS3 A	10005432
916 iS3 A	10005433
916 iS3 A	10005434
916 iS3 A	10005435
916 iS3 A	10005436
916 iS3 A	10005437
916 iS3 A	10005438
916 iS3 A	10005439
916 iS3 A	10005440
916 iS3 A	10005441
916 iSc3 B	10005472
916 iSc3 B	10005473
916 iSc3 B	10005474

Engine type	Engine S/N
916 iSc3 B	10005475
916 iSc3 B	10005476
916 iSc3 B	10005477
916 iSc3 B	10005478
916 iSc3 B	10005479
916 iSc3 B	10005480
916 iSc3 B	10005481
916 iSc3 B	10005482
916 iSc3 B	10005483
916 iSc3 B	10005495
916 iSc3 B	10005496
916 iSc3 B	10005497
916 iSc3 B	10005498
916 iSc3 B	10005499
916 iSc3 B	10005500
916 iSc3 B	10005501
916 iSc3 B	10005502
916 iSc3 B	10005503
916 iSc3 B	10005504
916 iSc3 B	10005505
916 iS3 A	10005519
916 iS3 A	10005520
916 iS3 A	10005521
916 iS3 A	10005522
916 iS3 A	10005523
916 iS3 A	10005524
916 iS3 A	10005525
916 iS3 A	10005526
916 iS3 A	10005527
916 iS3 A	10005528
916 iS3 A	10005529
916 iS3 A	10005530
912 iSc3 Sport	10005541
912 iSc2 Sport	10005542
912 iSc2 Sport	10005543
912 iSc2 Sport	10005544
916 iS2 A	10005545
916 iS2 A	10005546
916 iS2 A	10005547
916 iS2 A	10005548
916 iS2 A	10005549
916 iS2 A	10005550
916 iS2 A	10005551
915 iS2 C24	10005552
915 iS2 C24	10005553
912 iS2 Sport	10005554
912 iS2 Sport	10005555
912 iS2 Sport	10005556
912 iS3 Sport	10005557
912 iS3 Sport	10005558
912 iS3 Sport	10005559
912 iS3 Sport	10005560
912 iS3 Sport	10005561
912 iS3 Sport	10005562

Engine type	Engine S/N
912 iS3 Sport	10005563
912 iS3 Sport	10005564
912 iS3 Sport	10005565
912 iS3 Sport	10005566
912 iS2 Sport	10005567
912 iS2 Sport	10005568
912 iS2 Sport	10005569
912 iS2 Sport	10005570
912 iS2 Sport	10005571
912 iS2 Sport	10005572
912 iS2 Sport	10005573
912 iS2 Sport	10005574
912 iS2 Sport	10005575
912 iS2 Sport	10005576
912 iS2 Sport	10005577
912 iS2 Sport	10005578
912 iS2 Sport	10005579
912 iS2 Sport	10005580
912 iS2 Sport	10005581
912 iS2 Sport	10005582
912 iS2 Sport	10005583
912 iS2 Sport	10005584
912 iS2 Sport	10005585
912 iS2 Sport	10005586
915 iS3 A	10005587
915 iS3 A	10005588
915 iS3 A	10005589
915 iS3 A	10005590
915 iS3 A	10005591
915 iS3 A	10005592
915 iS3 A	10005593
915 iS3 A	10005594
915 iS3 A	10005595
915 iS3 A	10005596
915 iS3 A	10005597
915 iSc2 A	10005610
915 iSc2 A	10005611
915 iSc2 A	10005612
915 iSc2 A	10005613
915 iSc2 A	10005614
915 iSc2 A	10005615
915 iSc2 A	10005616
915 iSc2 A	10005617
915 iSc2 A	10005618
915 iSc2 A	10005619
916 iSc3 A	10005620
916 iS3 A	10005634
916 iS2 A	10005635
916 iS2 A	10005636
916 iS2 A	10005637
916 iS2 A	10005638
916 iS2 A	10005639
916 iS3 A	10005640
916 iS3 A	10005641

Engine type	Engine S/N
916 iS3 A	10005642
916 iS3 A	10005643
916 iS3 A	10005644
916 iS3 A	10005658
916 iS3 A	10005659
916 iS3 A	10005660
916 iS2 A	10005661
916 iS2 A	10005662
916 iS2 A	10005663
916 iS2 A	10005664
916 iS3 A	10005665
916 iS3 A	10005666
916 iS3 A	10005667
916 iS3 A	10005668
912 iS3 Sport	10005681
912 iS3 Sport	10005682
912 iS3 Sport	10005683
912 iS3 Sport	10005684
912 iS3 Sport	10005685
912 iS3 Sport	10005686
912 iS3 Sport	10005687
912 iS3 Sport	10005688
912 iS3 Sport	10005689
912 iS3 Sport	10005690
912 iS3 Sport	10005691
912 iS3 Sport	10005692
912 iS3 Sport	10005693
912 iS3 Sport	10005694
912 iS3 Sport	10005695
912 iS3 Sport	10005696
912 iS3 Sport	10005697
912 iS3 Sport	10005698
912 iS3 Sport	10005699
912 iS3 Sport	10005700
915 iS2 A	10005701
915 iS2 A	10005702
915 iS3 A	10005703
915 iS3 A	10005704
915 iS3 A	10005705
915 iS3 A	10005706
915 iS3 A	10005707
915 iS3 A	10005708
915 iS3 A	10005709
915 iS3 A	10005710
915 iS3 A	10005711
915 iS3 A	10005712
912 iS2 Sport	10005718
912 iS2 Sport	10005719
912 iS2 Sport	10005720
912 iS2 Sport	10005721
912 iS2 Sport	10005722
912 iS2 Sport	10005723
912 iS2 Sport	10005724
912 iS2 Sport	10005725

Engine type	Engine S/N
916 iSc3 B	10005726
916 iSc3 B	10005727
916 iSc3 B	10005728
916 iSc3 B	10005729
916 iSc3 B	10005730
916 iSc3 B	10005731
916 iSc3 B	10005732
916 iSc3 B	10005733
916 iSc3 B	10005734
916 iSc3 B	10005735
916 iSc3 B	10005736
912 iS3 Sport	10005737
912 iS3 Sport	10005738
912 iS3 Sport	10005739
912 iS3 Sport	10005740
912 iS3 Sport	10005741
912 iS3 Sport	10005742
912 iS3 Sport	10005743
912 iS3 Sport	10005744
912 iS3 Sport	10005745
912 iS3 Sport	10005746
912 iS3 Sport	10005747
912 iS3 Sport	10005748
916 iSc3 B	10005749
916 iSc3 B	10005750
916 iSc3 B	10005751
916 iSc3 B	10005752
916 iSc3 B	10005753
916 iS3 A	10005754
916 iS3 A	10005755
916 iS3 A	10005756
916 iS3 A	10005757
916 iS3 A	10005758
916 iS3 A	10005759
916 iS3 A	10005760
916 iS3 A	10005761
912 iS2 Sport	10005762
912 iS2 Sport	10005763
912 iS2 Sport	10005764
912 iS2 Sport	10005765
912 iS2 Sport	10005766
912 iS2 Sport	10005767
912 iS2 Sport	10005768
912 iS2 Sport	10005769
912 iS2 Sport	10005770
912 iS2 Sport	10005771
912 iS2 Sport	10005772
916 iS3 A	10005773
916 iS3 A	10005774
916 iS3 A	10005775
916 iS3 A	10005776
916 iS3 A	10005777
916 iS3 A	10005778
916 iS3 A	10005779

Engine type	Engine S/N
916 iS3 A	10005780
912 iS2 Sport	10005781
912 iS2 Sport	10005782
912 iS2 Sport	10005783
912 iS2 Sport	10005784
912 iS3 Sport	10005785
912 iS3 Sport	10005786
912 iS3 Sport	10005787
912 iS3 Sport	10005788
912 iS3 Sport	10005789
912 iS3 Sport	10005790
912 iS3 Sport	10005791
912 iS3 Sport	10005792
912 iS3 Sport	10005793
912 iS3 Sport	10005794
912 iS3 Sport	10005795
912 iS3 Sport	10005796
912 iS3 Sport	10005797
912 iS3 Sport	10005798
912 iS3 Sport	10005799
912 iS3 Sport	10005800
912 iS3 Sport	10005801
912 iS3 Sport	10005802
912 iS3 Sport	10005803
912 iS3 Sport	10005804
912 iS3 Sport	10005805
912 iS3 Sport	10005806
912 iS3 Sport	10005807
912 iS3 Sport	10005808
912 iS3 Sport	10005809
912 iS3 Sport	10005810
912 iS3 Sport	10005811
912 iS3 Sport	10005812
912 iS3 Sport	10005813
912 iS3 Sport	10005814
912 iS3 Sport	10005815
912 iS3 Sport	10005816
912 iS3 Sport	10005817
915 iS3 A	10005818
915 iS2 A	10005819
915 iS2 A	10005820
915 iS2 A	10005821
915 iS2 A	10005822
915 iS2 A	10005823
915 iS3 A	10005824
915 iS3 A	10005825
915 iS3 A	10005826
915 iS3 A	10005827
915 iS3 A	10005828
916 iSc2 A	10005845
916 iSc2 A	10005846
916 iSc2 A	10005847
916 iSc2 A	10005848
916 iSc2 A	10005849

Engine type	Engine S/N
916 iS3 A	10005850
916 iSc3 B	10005866
916 iSc3 B	10005867
916 iSc3 B	10005868
916 iSc3 B	10005869
916 iSc3 B	10005870
916 iSc3 B	10005871
916 iSc3 B	10005872
916 iSc3 B	10005873
916 iSc3 B	10005874
916 iSc3 B	10005875
916 iSc3 B	10005876
916 iSc3 B	10005892
916 iSc3 B	10005893
916 iSc3 B	10005894
916 iSc3 B	10005895
916 iSc3 B	10005896
916 iSc3 B	10005897
916 iSc3 B	10005898
916 iSc3 B	10005899
916 iSc3 B	10005900
916 iSc3 B	10005901
916 iSc3 B	10005902
912 iSc3 Sport	10005903
912 iS2 Sport	10005904
912 iS2 Sport	10005905
912 iS2 Sport	10005906
912 iS2 Sport	10005907
912 iS2 Sport	10005908
912 iS2 Sport	10005909
912 iS2 Sport	10005910
912 iS2 Sport	10005911
912 iS2 Sport	10005912
912 iS2 Sport	10005913
912 iS2 Sport	10005914
912 iS2 Sport	10005915
912 iS2 Sport	10005916
912 iS2 Sport	10005917
912 iS2 Sport	10005918
912 iS2 Sport	10005919
912 iS2 Sport	10005920
912 iS2 Sport	10005921
912 iS3 Sport	10005922
912 iS3 Sport	10005923
912 iS3 Sport	10005924
912 iS3 Sport	10005925
912 iS3 Sport	10005926
912 iS3 Sport	10005927
912 iS3 Sport	10005928
912 iS3 Sport	10005929
912 iS3 Sport	10005930
912 iS3 Sport	10005931
916 iS2 A	10005956
916 iS2 A	10005957

Engine type	Engine S/N
916 iS2 A	10005958
916 iS2 A	10005959
916 iS2 A	10005960
916 iS3 A	10005961
916 iS3 A	10005962
916 iS3 A	10005963
916 iS3 A	10005964
916 iS3 A	10005965
916 iS3 A	10005966
916 iS3 A	10005967
916 iS3 A	10005968
916 iS3 A	10005969
916 iS3 A	10005970
916 iS3 A	10005971
915 iS3 A	10005982
915 iS2 A	10005983
915 iS2 A	10005984
915 iS2 A	10005985
915 iS2 A	10005986
915 iS2 A	10005987
915 iS2 A	10005988
915 iS2 A	10005989
915 iS2 A	10005990
912 iSc3 Sport	10006008
912 iSc3 Sport	10006009
912 iSc3 Sport	10006010
912 iSc3 Sport	10006011
912 iSc3 Sport	10006012
912 iSc3 Sport	10006013
912 iSc3 Sport	10006014
912 iSc3 Sport	10006015
912 iS3 Sport	10006016
912 iS3 Sport	10006017
912 iS3 Sport	10006018
912 iS3 Sport	10006019
912 iS3 Sport	10006020
912 iS3 Sport	10006021
912 iS3 Sport	10006022
912 iS3 Sport	10006023
915 iSc3 A	10006024
915 iSc3 A	10006025
916 iSc3 B	10006026
916 iSc3 B	10006027
916 iSc3 B	10006028
916 iSc3 B	10006029
916 iSc3 B	10006030
916 iSc3 B	10006031
916 iSc3 B	10006032
916 iSc3 B	10006033
916 iSc3 B	10006034
916 iSc3 B	10006045
916 iSc3 B	10006046
916 iSc3 B	10006047
916 iSc3 B	10006048

Engine type	Engine S/N
916 iSc3 B	10006049
916 iSc3 B	10006050
916 iSc3 B	10006051
916 iSc3 B	10006052
916 iSc3 B	10006053
916 iSc3 B	10006054
916 iSc3 B	10006055
912 iS3 Sport	10006061
912 iS3 Sport	10006062
912 iS3 Sport	10006063
912 iS3 Sport	10006064
912 iS3 Sport	10006065
912 iS3 Sport	10006066
912 iS3 Sport	10006067
912 iS3 Sport	10006068
912 iS3 Sport	10006069
916 iSc3 B	10006070
916 iSc3 B	10006071
916 iSc3 B	10006072
916 iSc3 B	10006073
916 iSc3 B	10006074
916 iSc3 B	10006075
916 iSc3 B	10006076
916 iSc3 B	10006077
916 iSc3 B	10006078
916 iSc3 B	10006079
916 iSc3 B	10006080
912 iS3 Sport	10006081
912 iS3 Sport	10006082
912 iS3 Sport	10006083
912 iS3 Sport	10006084
912 iS3 Sport	10006085
912 iS3 Sport	10006086
912 iS3 Sport	10006087
912 iS3 Sport	10006088
912 iS3 Sport	10006089
912 iS3 Sport	10006090
912 iS3 Sport	10006091
912 iS3 Sport	10006092
912 iS3 Sport	10006093
916 iSc3 B	10006094
916 iSc3 B	10006095
916 iSc3 B	10006096
916 iSc3 B	10006097
916 iSc3 B	10006098
916 iSc3 B	10006099
916 iSc3 B	10006100
916 iSc3 B	10006101
916 iSc3 B	10006102
916 iSc3 B	10006103
916 iSc3 B	10006104
912 iS3 Sport	10006105
912 iS3 Sport	10006106
912 iS3 Sport	10006107

Engine type	Engine S/N
912 iS3 Sport	10006108
912 iS3 Sport	10006109
912 iS3 Sport	10006110
912 iS3 Sport	10006111
912 iS3 Sport	10006112
912 iS3 Sport	10006113
912 iS3 Sport	10006114
912 iS3 Sport	10006115
912 iS3 Sport	10006116
912 iS3 Sport	10006117
912 iS3 Sport	10006118
912 iS3 Sport	10006119
912 iS3 Sport	10006120
912 iS3 Sport	10006121
912 iS3 Sport	10006122
912 iS3 Sport	10006123
912 iS3 Sport	10006124
912 iS3 Sport	10006125
912 iS3 Sport	10006126
912 iS3 Sport	10006127
912 iS3 Sport	10006128
912 iS3 Sport	10006129
912 iS3 Sport	10006130
912 iS3 Sport	10006131
912 iS3 Sport	10006132
912 iS2 Sport	10006133
912 iS2 Sport	10006134
912 iS2 Sport	10006135
912 iS2 Sport	10006136
912 iS2 Sport	10006137
912 iS2 Sport	10006138
915 iS3 A	10006139
915 iS3 A	10006140
915 iS2 A	10006141
915 iS2 A	10006142
915 iS2 A	10006143
915 iS2 A	10006144
915 iS2 A	10006145
915 iS2 A	10006146
915 iS2 A	10006147
915 iS2 A	10006148
915 iS2 A	10006149
915 iS2 A	10006150
915 iS3 A	10006161
915 iS3 A	10006162
915 iS3 A	10006163
916 iS3 A	10006164
916 iS3 A	10006165
916 iS3 A	10006166
916 iS3 A	10006167
916 iS3 A	10006168
916 iS3 A	10006169
916 iS3 A	10006170
916 iS3 A	10006185

Engine type	Engine S/N
916 iS3 A	10006186
916 iS3 A	10006187
916 iS3 A	10006188
916 iS3 A	10006189
916 iS3 A	10006190
916 iS3 A	10006191
916 iS3 A	10006192
916 iS3 A	10006193
916 iS3 A	10006194
916 iS3 A	10006195
912 iS2 Sport	10006206
912 iS2 Sport	10006207
912 iS2 Sport	10006208
916 iS3 A	10006209
916 iS3 A	10006210
916 iS3 A	10006211
916 iS3 A	10006212
916 iS3 A	10006213
916 iS3 A	10006214
916 iS3 A	10006215
916 iS3 A	10006216
916 iS3 A	10006217
916 iS3 A	10006218
916 iS3 A	10006219
912 iS2 Sport	10006220
912 iS2 Sport	10006221
912 iS2 Sport	10006222
912 iS2 Sport	10006223
912 iS2 Sport	10006224
912 iS2 Sport	10006225
912 iS2 Sport	10006226
912 iS2 Sport	10006227
912 iS2 Sport	10006228
912 iS2 Sport	10006229
912 iS2 Sport	10006230
912 iS2 Sport	10006231
912 iS2 Sport	10006232
912 iS2 Sport	10006233
912 iS2 Sport	10006234
912 iS2 Sport	10006235
912 iS2 Sport	10006236
912 iS2 Sport	10006237
912 iS2 Sport	10006238
912 iS2 Sport	10006239
912 iS2 Sport	10006240
912 iS2 Sport	10006241
912 iS2 Sport	10006242
912 iS2 Sport	10006243
912 iS2 Sport	10006244
912 iS2 Sport	10006245
912 iS2 Sport	10006246
912 iS2 Sport	10006247
912 iS2 Sport	10006248
912 iS2 Sport	10006249

Engine type	Engine S/N
912 iS2 Sport	10006250
912 iS2 Sport	10006251
912 iS2 Sport	10006252
912 iS2 Sport	10006253
912 iS2 Sport	10006254
916 iS3 A	10006255
916 iS3 A	10006256
916 iS3 A	10006257
912 iSc3 Sport	10006258
912 iSc3 Sport	10006259
915 iS3 A	10006264
916 iSc3 A	10006265
916 iSc3 A	10006266
916 iSc2 A	10006267
916 iSc2 A	10006268
916 iSc2 A	10006269
916 iSc2 A	10006270
916 iSc2 A	10006271
915 iSc3 A	10006276
915 iSc3 A	10006277
915 iSc2 A	10006278
915 iSc2 A	10006279
915 iSc2 A	10006280
915 iSc2 A	10006281
915 iSc2 A	10006282
915 iSc2 A	10006283
915 iSc2 A	10006284
915 iSc2 A	10006285
916 iSc2 C24	10006286
912 iSc3 Sport	10006291
912 iSc3 Sport	10006292
912 iSc3 Sport	10006293
912 iSc3 Sport	10006294
912 iSc3 Sport	10006295
912 iSc3 Sport	10006296
912 iSc3 Sport	10006297
912 iSc3 Sport	10006298
912 iSc3 Sport	10006299
912 iSc3 Sport	10006300
916 iSc3 B	10006301
916 iSc3 B	10006302
916 iSc3 B	10006303
916 iSc3 B	10006304
916 iSc3 B	10006305
916 iSc3 B	10006306
916 iSc3 B	10006307
916 iSc3 B	10006308
916 iSc3 B	10006309
916 iSc3 B	10006310
916 iSc3 B	10006311
912 iS3 Sport	10006312
912 iS3 Sport	10006313
912 iS3 Sport	10006314
912 iS3 Sport	10006315

Engine type	Engine S/N
912 iS3 Sport	10006316
912 iS3 Sport	10006317
912 iS3 Sport	10006318
912 iS3 Sport	10006319
912 iS3 Sport	10006320
912 iS3 Sport	10006321
912 iS3 Sport	10006322
912 iS3 Sport	10006323
916 iSc3 B	10006324
916 iSc3 B	10006325
916 iSc3 B	10006326
916 iSc3 B	10006327
916 iSc3 B	10006328
916 iSc3 B	10006329
916 iSc3 B	10006330
916 iSc3 B	10006331
916 iSc3 B	10006332
916 iSc3 B	10006333
916 iSc3 B	10006334
912 iS3 Sport	10006335
912 iS3 Sport	10006336
912 iS3 Sport	10006337
912 iS3 Sport	10006338
912 iS3 Sport	10006339
912 iS3 Sport	10006340
912 iS3 Sport	10006341
912 iS3 Sport	10006342
912 iS3 Sport	10006343
912 iS3 Sport	10006344
912 iS3 Sport	10006345
912 iS3 Sport	10006346
912 iS3 Sport	10006347
912 iS3 Sport	10006348
912 iS3 Sport	10006349
912 iS3 Sport	10006350
912 iS3 Sport	10006351
912 iS3 Sport	10006352
912 iS3 Sport	10006353
912 iS3 Sport	10006354
912 iS3 Sport	10006355
912 iS3 Sport	10006356
912 iS3 Sport	10006357
912 iS3 Sport	10006358
912 iS3 Sport	10006359
912 iS3 Sport	10006360
912 iS3 Sport	10006361
912 iS3 Sport	10006362
912 iS3 Sport	10006363
912 iS3 Sport	10006364
912 iS3 Sport	10006365
912 iS3 Sport	10006366
912 iS3 Sport	10006367
916 iS3 A	10006400
916 iS3 A	10006401

Engine type	Engine S/N
916 iS3 A	10006402
916 iS3 A	10006403
912 iSc3 Sport	10006404
912 iSc3 Sport	10006405
912 iSc3 Sport	10006406
912 iSc3 Sport	10006407
912 iSc3 Sport	10006408
912 iSc3 Sport	10006409
912 iS3 Sport	10006410
912 iS3 Sport	10006411
912 iS3 Sport	10006412
912 iS3 Sport	10006413
912 iS3 Sport	10006414
916 iSc3 B	10006415
916 iSc3 B	10006416
916 iSc3 B	10006417
916 iSc3 B	10006418
916 iSc3 B	10006419
916 iSc3 B	10006420
916 iSc3 B	10006421
916 iSc3 B	10006422
916 iSc3 B	10006423
916 iSc3 B	10006424
916 iSc3 B	10006425
916 iSc3 B	10006426
912 iS3 Sport	10006427
912 iS3 Sport	10006428
912 iS3 Sport	10006429
912 iS3 Sport	10006430
912 iS3 Sport	10006431
912 iS2 Sport	10006432
912 iS2 Sport	10006433
912 iS2 Sport	10006434
912 iS2 Sport	10006435
912 iS2 Sport	10006436
912 iS3 Sport	10006437
912 iS3 Sport	10006438
912 iS3 Sport	10006439
912 iS3 Sport	10006440
912 iS3 Sport	10006441
912 iS3 Sport	10006442
912 iS3 Sport	10006443
912 iS3 Sport	10006444
912 iS3 Sport	10006445
912 iS3 Sport	10006446
912 iS3 Sport	10006447
912 iS3 Sport	10006448
912 iS3 Sport	10006449
912 iS3 Sport	10006450
912 iS3 Sport	10006451
912 iS3 Sport	10006452
912 iS3 Sport	10006453
912 iS3 Sport	10006454
912 iS3 Sport	10006455

Engine type	Engine S/N
912 iS3 Sport	10006456
912 iS3 Sport	10006457
912 iS3 Sport	10006458
912 iS3 Sport	10006459
912 iS3 Sport	10006460
912 iS3 Sport	10006461
912 iSc3 Sport	10006482
912 iSc3 Sport	10006483
912 iSc3 Sport	10006484
912 iSc3 Sport	10006485
912 iSc3 Sport	10006486
912 iSc3 Sport	10006487
912 iSc3 Sport	10006488
912 iSc3 Sport	10006489
912 iSc3 Sport	10006490
912 iSc3 Sport	10006491
912 iSc3 Sport	10006492
912 iSc3 Sport	10006493
912 iSc3 Sport	10006494
912 iSc3 Sport	10006495
912 iSc3 Sport	10006496
915 iS2 A	10006497
915 iS2 A	10006498
915 iS2 A	10006499
915 iS2 A	10006500
915 iS2 A	10006501
915 iS2 A	10006502
915 iS2 A	10006503
915 iS2 A	10006504
915 iS2 A	10006505
915 iS2 A	10006506
912 iS3 Sport	10006507
912 iS3 Sport	10006508
912 iS3 Sport	10006509
912 iS3 Sport	10006510
912 iS3 Sport	10006511
912 iS3 Sport	10006512
912 iS3 Sport	10006513
912 iS3 Sport	10006514
912 iS3 Sport	10006515
912 iS3 Sport	10006516
912 iS3 Sport	10006517
912 iS3 Sport	10006518
912 iS3 Sport	10006519
912 iS3 Sport	10006520
912 iS3 Sport	10006521
912 iS3 Sport	10006522
912 iS3 Sport	10006523
912 iS3 Sport	10006524
912 iS3 Sport	10006525
912 iS3 Sport	10006526
912 iS3 Sport	10006527
912 iS3 Sport	10006528
912 iS3 Sport	10006529

Engine type	Engine S/N
912 iS3 Sport	10006530
912 iS3 Sport	10006531
915 iS3 A	10006532
915 iS3 A	10006533
915 iS3 A	10006534
915 iS3 A	10006535
915 iS3 A	10006536
915 iS3 A	10006537
915 iS2 A	10006538
915 iS2 A	10006539
915 iS2 A	10006540
915 iS2 A	10006541
915 iS2 A	10006542
916 iS3 C24	10006556
916 iS3 C24	10006557
916 iS3 C24	10006558
916 iS3 C24	10006559
916 iS3 C24	10006560
916 iS3 A	10006561
916 iS3 A	10006562
916 iS3 A	10006563
916 iS3 A	10006564
916 iS3 A	10006565
916 iS3 A	10006566
912 iSc3 Sport	10006567
912 iSc3 Sport	10006568
912 iSc3 Sport	10006569
912 iSc3 Sport	10006570
912 iSc3 Sport	10006571
912 iSc3 Sport	10006572
912 iSc3 Sport	10006573
912 iSc3 Sport	10006574
912 iSc3 Sport	10006575
912 iSc3 Sport	10006576
912 iS2 Sport	10006577
916 iS3 A	10006578
916 iS3 A	10006579
916 iS3 A	10006580
916 iS3 A	10006581
916 iS3 A	10006582
916 iS3 A	10006583
916 iS3 A	10006584
916 iS3 A	10006585
916 iS3 A	10006586
916 iS3 A	10006587
912 iS3 Sport	10006588
912 iS3 Sport	10006589
912 iS3 Sport	10006590
912 iS3 Sport	10006591
912 iS3 Sport	10006592
912 iS2 Sport	10006593
912 iS2 Sport	10006594
912 iS2 Sport	10006595
912 iS2 Sport	10006596

Engine type	Engine S/N
912 iS2 Sport	10006597
912 iS2 Sport	10006598
912 iS2 Sport	10006599
912 iS2 Sport	10006600
912 iS2 Sport	10006601
912 iS2 Sport	10006602
916 iS2 A	10006603
916 iS2 A	10006604
916 iS2 A	10006605
916 iS2 A	10006606
916 iS2 A	10006607
916 iS2 A	10006608
916 iS2 A	10006609
916 iS2 A	10006610
916 iS2 A	10006611
916 iS2 A	10006612
912 iS2 Sport	10006613
912 iS2 Sport	10006614
912 iS3 Sport	10006615
912 iS3 Sport	10006616
912 iS3 Sport	10006617
912 iS3 Sport	10006618
912 iS3 Sport	10006619
912 iS3 Sport	10006620
912 iS3 Sport	10006621
912 iS3 Sport	10006622
912 iS3 Sport	10006623
912 iS3 Sport	10006624
912 iS3 Sport	10006625
912 iS3 Sport	10006626
912 iS3 Sport	10006627
912 iS3 Sport	10006628
912 iS3 Sport	10006629
912 iS3 Sport	10006630
912 iS3 Sport	10006631
912 iS3 Sport	10006632
912 iS3 Sport	10006633
912 iS3 Sport	10006634
912 iS3 Sport	10006635
912 iS3 Sport	10006636
912 iS3 Sport	10006637
912 iS3 Sport	10006638
912 iS3 Sport	10006639
912 iS3 Sport	10006640
912 iS3 Sport	10006641
912 iS3 Sport	10006642
912 iS3 Sport	10006643
912 iS3 Sport	10006644
912 iS3 Sport	10006645
912 iS3 Sport	10006646
912 iS3 Sport	10006647
912 iS3 Sport	10006648
912 iS3 Sport	10006649
916 iS3 A	10006650

Engine type	Engine S/N
916 iS3 A	10006651
916 iS3 A	10006652
916 iS3 A	10006653
916 iS3 A	10006654
916 iS3 A	10006655
916 iS3 A	10006656
916 iS3 A	10006657
916 iS3 A	10006658
916 iS3 A	10006659
915 iS3 A	10006660
915 iS3 A	10006661
915 iS3 A	10006662
915 iS3 A	10006663
915 iS3 A	10006664
915 iS3 A	10006665
915 iS3 A	10006681
915 iS3 A	10006682
915 iS3 A	10006683
915 iS3 A	10006684
915 iS3 A	10006685
915 iS3 A	10006686
915 iS3 A	10006687
915 iS3 A	10006688
915 iS3 A	10006689
915 iS3 A	10006690
915 iSc3 A	10006700
915 iSc3 A	10006701
915 iSc3 A	10006702
915 iSc3 A	10006703
915 iSc3 A	10006704
915 iSc3 A	10006705
912 iS2 Sport	10006709
912 iS2 Sport	10006710
912 iS2 Sport	10006711
912 iS2 Sport	10006712
912 iS2 Sport	10006713
912 iS2 Sport	10006714
912 iS2 Sport	10006715
912 iS2 Sport	10006716
912 iS2 Sport	10006717
912 iS2 Sport	10006718
912 iS2 Sport	10006719
912 iS2 Sport	10006720
912 iS2 Sport	10006721
912 iS2 Sport	10006722
912 iS2 Sport	10006723
912 iS2 Sport	10006724
912 iS2 Sport	10006725
912 iS2 Sport	10006726
912 iS2 Sport	10006727
912 iS2 Sport	10006728
912 iS2 Sport	10006729
912 iS2 Sport	10006730
912 iS2 Sport	10006731

Engine type	Engine S/N
912 iS2 Sport	10006732
912 iS2 Sport	10006733
915 iS2 A	10006740
915 iS2 A	10006741
915 iS2 A	10006742
915 iS2 A	10006743
915 iS2 A	10006744
915 iS3 A	10006745
915 iS3 A	10006746
915 iS3 A	10006747
915 iS3 A	10006748
915 iS3 A	10006749
912 iSc3 Sport	10006750
912 iS3 Sport	10006751
912 iS3 Sport	10006752
912 iS3 Sport	10006753
912 iS3 Sport	10006754
912 iS3 Sport	10006755
912 iS3 Sport	10006756
912 iS3 Sport	10006757
912 iS3 Sport	10006758
912 iS3 Sport	10006759
912 iS3 Sport	10006760
912 iS3 Sport	10006761
912 iS3 Sport	10006762
912 iS3 Sport	10006763
912 iS3 Sport	10006764
912 iS3 Sport	10006765
912 iS3 Sport	10006766
916 iS3 A	10006767
916 iS2 A	10006768
916 iS2 A	10006769
916 iS2 A	10006770
916 iS2 A	10006771
916 iS2 A	10006772
916 iS3 A	10006773
916 iS3 A	10006774
916 iS3 A	10006775
916 iS3 A	10006776
916 iS3 A	10006777
916 iS2 A	10006778
912 iS2 Sport	10006780
912 iS2 Sport	10006781
912 iS2 Sport	10006782
912 iS2 Sport	10006783
912 iS2 Sport	10006784
915 iSc3 A	10006805
915 iSc3 A	10006806
915 iSc3 A	10006807
915 iSc3 A	10006808
916 iS3 A	10006809
916 iS3 A	10006810
916 iS3 A	10006811
916 iS3 A	10006812

Engine type	Engine S/N
916 iS3 A	10006813
916 iS3 A	10006814
916 iS3 A	10006815
916 iS3 A	10006826
916 iS3 A	10006827
916 iS3 A	10006828
916 iS3 A	10006829
916 iS3 A	10006830
916 iS3 A	10006831
916 iS3 A	10006832
916 iS3 A	10006833
916 iS3 A	10006834
916 iS3 A	10006835
916 iS3 A	10006836
916 iS3 A	10006837
916 iS3 A	10006851
916 iS3 A	10006852
916 iS3 A	10006853
916 iS3 A	10006854
916 iS3 A	10006855
916 iS3 A	10006856
916 iS3 A	10006857
916 iS3 A	10006858
916 iS3 A	10006874
916 iS3 A	10006875
916 iS3 A	10006876
916 iS3 A	10006877
916 iS3 A	10006878
916 iS3 A	10006879
916 iS3 A	10006880
916 iS3 A	10006881
916 iS3 A	10006882
916 iS3 A	10006883
912 iS2 Sport	10006884
912 iS2 Sport	10006885
912 iS2 Sport	10006886
912 iS2 Sport	10006887
912 iS2 Sport	10006888
912 iS2 Sport	10006889
912 iS2 Sport	10006890
912 iS2 Sport	10006891
912 iS2 Sport	10006892
912 iS2 Sport	10006893
912 iS2 Sport	10006894
912 iS2 Sport	10006895
912 iS2 Sport	10006896
912 iS2 Sport	10006897
912 iS2 Sport	10006898
912 iS2 Sport	10006899
912 iS2 Sport	10006900
912 iS2 Sport	10006901
912 iS2 Sport	10006902
912 iS2 Sport	10006903
912 iS2 Sport	10006904

Engine type	Engine S/N
912 iS2 Sport	10006905
912 iS2 Sport	10006906
912 iS2 Sport	10006907
912 iS2 Sport	10006908
912 iS2 Sport	10006909
912 iS2 Sport	10006910
912 iS2 Sport	10006911
912 iS2 Sport	10006912
912 iS2 Sport	10006913
916 iSc3 B	10006914
916 iSc3 B	10006915
916 iSc3 B	10006916
916 iSc3 B	10006917
916 iSc3 B	10006918
916 iSc3 B	10006919
916 iSc3 B	10006920
916 iSc3 B	10006921
916 iSc3 B	10006922
916 iSc3 B	10006923
916 iSc3 B	10006924
916 iSc3 B	10006925
916 iSc3 B	10006926
915 iSc2 A	10006958
912 iSc3 Sport	10007009
912 iSc3 Sport	10007010
912 iSc3 Sport	10007011
912 iSc3 Sport	10007012
912 iSc3 Sport	10007013
912 iS2 Sport	10007014
912 iS2 Sport	10007015
912 iS3 Sport	10007016
912 iS3 Sport	10007017
912 iS3 Sport	10007018
912 iS3 Sport	10007019
912 iS3 Sport	10007020
912 iS3 Sport	10007021
912 iS3 Sport	10007022
912 iS3 Sport	10007023
912 iS3 Sport	10007024
912 iS3 Sport	10007025
916 iS3 A	10007070
916 iS3 A	10007071
912 iS3 Sport	10007102
912 iS3 Sport	10007103
912 iS3 Sport	10007104
912 iS3 Sport	10007105
912 iS3 Sport	10007106
912 iS3 Sport	10007107
912 iS3 Sport	10007108
912 iS3 Sport	10007109
912 iS3 Sport	10007110
912 iS3 Sport	10007111
912 iS3 Sport	10007112
912 iS3 Sport	10007113

Engine type	Engine S/N
912 iS3 Sport	10007114
912 iS3 Sport	10007115
912 iS3 Sport	10007116
912 iS3 Sport	10007117
912 iS3 Sport	10007118
912 iS3 Sport	10007119
912 iS3 Sport	10007120
912 iS3 Sport	10007121
916 iS3 A	10007132
916 iS3 A	10007133
916 iS3 A	10007134
915 iSc3 A	10007135
915 iSc3 A	10007136
915 iSc3 A	10007137
915 iSc3 A	10007138
915 iSc3 A	10007139
915 iSc3 A	10007140
915 iSc3 A	10007141
915 iSc3 A	10007142
915 iSc3 A	10007143
915 iS3 A	10007154
915 iS3 A	10007155
915 iS3 A	10007156
915 iS3 A	10007157
915 iS3 A	10007158
915 iS3 A	10007159
915 iS3 A	10007160
915 iS3 A	10007161
915 iS3 A	10007162
915 iS3 A	10007163
915 iS3 A	10007164
916 iS3 A	10007180
916 iS3 A	10007181
916 iS3 A	10007182
916 iS3 A	10007183
916 iS3 A	10007184
916 iS3 A	10007185
916 iS3 A	10007186
916 iS3 A	10007187
916 iS3 A	10007188
916 iS3 A	10007189
916 iS3 A	10007190
916 iS3 A	10007206
916 iS3 A	10007207
916 iS3 A	10007208
916 iS3 A	10007209
916 iS3 A	10007210
916 iS3 A	10007211
916 iS3 A	10007212
916 iS3 A	10007213
916 iS3 A	10007214
916 iS3 A	10007215
912 iSc3 Sport	10007216
912 iSc3 Sport	10007217

Engine type	Engine S/N
912 iSc3 Sport	10007218
912 iSc3 Sport	10007219
912 iS2 Sport	10007220
912 iS2 Sport	10007221
912 iS2 Sport	10007222
912 iS2 Sport	10007223
912 iS2 Sport	10007224
912 iS2 Sport	10007225
912 iS2 Sport	10007226
912 iS2 Sport	10007227
912 iS2 Sport	10007228
912 iS2 Sport	10007229
912 iS3 Sport	10007230
912 iS3 Sport	10007231
912 iS2 Sport	10007232
912 iS2 Sport	10007233
912 iS2 Sport	10007234
912 iS2 Sport	10007235
912 iS2 Sport	10007236
912 iS2 Sport	10007237
912 iS2 Sport	10007238
912 iS2 Sport	10007239
912 iS2 Sport	10007240
912 iS2 Sport	10007241
916 iS3 A	10007252
916 iS3 A	10007253
916 iS3 A	10007254
916 iS2 A	10007255
916 iS2 A	10007256
916 iS2 A	10007257
916 iS2 A	10007258
916 iS2 A	10007259
916 iS2 A	10007270
916 iS2 A	10007271
916 iS2 A	10007272
916 iS2 A	10007273
916 iS2 A	10007274
916 iS3 A	10007275
916 iS3 A	10007276
916 iS3 A	10007277
916 iS3 A	10007278
916 iS3 A	10007279
912 iSc3 Sport	10007280
912 iSc3 Sport	10007281
912 iSc3 Sport	10007282
912 iSc3 Sport	10007283
912 iSc3 Sport	10007284
912 iSc3 Sport	10007285
912 iSc3 Sport	10007286
912 iSc3 Sport	10007287
912 iSc3 Sport	10007288
912 iSc3 Sport	10007289
912 iS3 Sport	10007290
912 iS3 Sport	10007291

Engine type	Engine S/N
912 iS3 Sport	10007292
912 iS3 Sport	10007293
912 iS3 Sport	10007294
915 iS3 A	10007295
915 iS2 A	10007296
915 iS2 A	10007297
915 iS2 A	10007298
915 iS2 A	10007299
915 iS2 A	10007300
915 iS2 A	10007301
915 iS2 A	10007302
915 iS2 A	10007303
915 iS2 A	10007304
915 iS2 A	10007305
912 iS3 Sport	10007306
912 iS3 Sport	10007307
912 iS3 Sport	10007308
912 iS3 Sport	10007309
912 iS3 Sport	10007310
912 iS3 Sport	10007311
912 iS3 Sport	10007312
912 iS3 Sport	10007313
912 iS3 Sport	10007314
912 iS3 Sport	10007315
912 iS3 Sport	10007316
912 iS3 Sport	10007317
912 iS3 Sport	10007318
912 iS3 Sport	10007319
912 iS3 Sport	10007320
912 iS3 Sport	10007321
912 iS3 Sport	10007322
912 iS3 Sport	10007323
912 iS3 Sport	10007324
912 iS3 Sport	10007325
912 iS3 Sport	10007326
912 iS3 Sport	10007327
912 iS3 Sport	10007328
912 iS3 Sport	10007329
912 iS3 Sport	10007330
912 iS3 Sport	10007331
912 iS3 Sport	10007332
912 iS3 Sport	10007333
912 iS3 Sport	10007334
912 iS3 Sport	10007335
912 iS3 Sport	10007336
912 iS3 Sport	10007337
912 iS3 Sport	10007338
912 iS3 Sport	10007339
912 iS3 Sport	10007340
912 iS3 Sport	10007341
912 iS3 Sport	10007342
912 iS3 Sport	10007343
912 iS3 Sport	10007344
916 iS3 A	10007357

Engine type	Engine S/N
916 iS3 A	10007358
916 iS3 A	10007359
915 iS3 A	10007420
915 iS3 A	10007421
916 iS3 A	10007422
916 iS3 A	10007423
916 iS3 A	10007424
916 iS3 A	10007425
916 iS3 A	10007426
916 iS3 A	10007427
912 iSc3 Sport	10007479
912 iSc3 Sport	10007480
912 iSc3 Sport	10007481
912 iSc3 Sport	10007482
912 iSc3 Sport	10007483
912 iS2 Sport	10007518
912 iS2 Sport	10007519
912 iS2 Sport	10007520
912 iS2 Sport	10007521
912 iS2 Sport	10007522
912 iS2 Sport	10007523
912 iS2 Sport	10007524
912 iS2 Sport	10007525
916 iS3 A	10007531
916 iS3 A	10007532
916 iS3 A	10007533
916 iS3 A	10007534
916 iS3 A	10007535
916 iS3 A	10007536
916 iS3 A	10007537
916 iS3 A	10007538
916 iS3 A	10007539
916 iS3 A	10007540
916 iS3 A	10007541
916 iS3 A	10007542
912 iS2 Sport	10007626
912 iS2 Sport	10007627
912 iS2 Sport	10007628
912 iS3 Sport	10007629
912 iS3 Sport	10007630
912 iS3 Sport	10007631
912 iS3 Sport	10007632
912 iS3 Sport	10007633
912 iS2 Sport	10007634
912 iS2 Sport	10007635
912 iS2 Sport	10007636
912 iS2 Sport	10007637
912 iS2 Sport	10007638
912 iS2 Sport	10007639
912 iS2 Sport	10007640
912 iS2 Sport	10007641
915 iS3 A	10007642
916 iS3 C24	10007677
916 iS3 C24	10007678

Engine type	Engine S/N
916 iS3 C24	10007679
916 iS3 C24	10007680
916 iS3 C24	10007681
916 iS3 A	10007682
916 iS3 A	10007683
916 iS3 A	10007684
916 iS3 A	10007698
916 iS3 A	10007699
916 iS3 A	10007700
916 iS3 A	10007701
916 iS3 A	10007702
916 iS3 A	10007703
916 iS3 A	10007704
916 iS3 A	10007705
916 iS3 A	10007706
916 iS3 A	10007707
916 iS3 A	10007708
916 iS3 A	10007709
916 iS3 A	10007710
916 iS3 A	10007711
916 iS3 A	10007712
916 iS3 A	10007713
916 iS3 A	10007714
916 iS3 A	10007727
916 iS3 A	10007728
916 iS3 A	10007729
916 iS3 A	10007730
916 iS3 A	10007731
916 iS3 A	10007732
916 iS3 A	10007733
916 iS3 A	10007734
916 iS3 A	10007735
916 iS3 A	10007736
916 iS3 A	10007737
916 iS3 A	10007738
916 iS3 A	10007739
916 iS3 A	10007740
916 iS3 A	10007741
915 iS3 A	10007849
915 iS3 A	10007850
915 iS3 A	10007851
915 iS3 A	10007852
915 iS3 A	10007853
915 iS3 A	10007854
915 iS3 A	10007855
915 iS3 A	10007856
915 iS3 A	10007857
915 iS3 A	10007858
916 iS3 A	10007859
916 iS3 C24	10007920
916 iS3 C24	10007921
916 iS3 C24	10007922
916 iS3 C24	10007923
916 iS3 C24	10007924

Engine type	Engine S/N
916 iS3 A	10007925
916 iS3 A	10007926
916 iS3 A	10007927
916 iS3 A	10007928
916 iS3 A	10007929
915 iS3 A	10007945
915 iS3 A	10007946
915 iS3 A	10007947
915 iS3 A	10007948
915 iS3 A	10007949
915 iS2 A	10007950
915 iS2 A	10007951
915 iS2 A	10007952
915 iS2 A	10007953
915 iS2 A	10007954
912 iS3 Sport	10007975
912 iS3 Sport	10007976
912 iS3 Sport	10007977
912 iS3 Sport	10007978
912 iS3 Sport	10007979
912 iS3 Sport	10007980
912 iS3 Sport	10007981
912 iS3 Sport	10007982
912 iS3 Sport	10007983
912 iS3 Sport	10007984
912 iS2 Sport	10007985
912 iS2 Sport	10007986
916 iS3 A	10007987
916 iS3 A	10007988
916 iS3 A	10007989
916 iS3 A	10007990
916 iS3 A	10007991
916 iS3 A	10007992
916 iS3 A	10007993
916 iS3 A	10007994
916 iS3 A	10007995
916 iS3 A	10007996
916 iS3 A	10008009
916 iS3 A	10008010
916 iS3 A	10008011
916 iS3 A	10008012
916 iS3 A	10008013
916 iS3 A	10008014
916 iS3 A	10008015
916 iS3 A	10008016
916 iS3 A	10008017
916 iS3 A	10008018
916 iS3 A	10008019
916 iS3 A	10008020
912 iS2 Sport	10008032
912 iS2 Sport	10008033
912 iS2 Sport	10008034
912 iS2 Sport	10008035
916 iS3 A	10008036

Engine type	Engine S/N
916 iS3 A	10008037
916 iS3 C24	10008038
915 iS3 A	10008039
915 iS3 A	10008040
915 iS3 A	10008041
915 iS3 A	10008042
915 iS3 A	10008043
912 iS2 Sport	10008044
912 iS2 Sport	10008045
912 iS2 Sport	10008046
912 iS2 Sport	10008047
912 iS2 Sport	10008048
912 iS2 Sport	10008049
912 iS2 Sport	10008050
912 iS2 Sport	10008051
912 iS2 Sport	10008052
912 iS2 Sport	10008053
912 iS2 Sport	10008054
912 iS2 Sport	10008055
912 iS2 Sport	10008056
912 iS2 Sport	10008057
912 iS2 Sport	10008058
912 iS2 Sport	10008059
915 iS3 A	10008060
915 iS3 A	10008061
915 iS3 A	10008062
915 iS3 A	10008063
915 iS3 A	10008064
915 iS3 A	10008065
915 iS3 A	10008066
915 iS3 A	10008067
915 iS3 A	10008068
915 iS3 A	10008069
915 iS3 A	10008070
915 iS3 A	10008071
912 iS2 Sport	10008072
912 iS2 Sport	10008073
912 iS2 Sport	10008074
912 iS2 Sport	10008075
912 iS2 Sport	10008076
912 iS2 Sport	10008077
912 iS2 Sport	10008078
912 iS2 Sport	10008079
912 iS2 Sport	10008080
912 iS2 Sport	10008081
912 iS3 Sport	10008082
912 iS3 Sport	10008083
912 iS3 Sport	10008084
912 iS3 Sport	10008085
912 iS3 Sport	10008086
912 iS3 Sport	10008087
912 iS3 Sport	10008088
912 iS3 Sport	10008089
912 iS3 Sport	10008090

Engine type	Engine S/N
912 iS3 Sport	10008091
912 iS3 Sport	10008092
912 iS3 Sport	10008093
912 iS3 Sport	10008094
912 iS3 Sport	10008095
912 iS3 Sport	10008096
912 iS3 Sport	10008097
912 iS3 Sport	10008098
912 iS3 Sport	10008099
912 iS3 Sport	10008100
912 iS3 Sport	10008101
916 iS3 C24	10008102
916 iS3 C24	10008104
916 iS3 C24	10008105
916 iS3 C24	10008106
916 iS3 C24	10008107
916 iS3 C24	10008108
916 iS3 C24	10008109
916 iS3 C24	10008110
916 iS3 C24	10008111
912 iS3 Sport	10008122
912 iS3 Sport	10008123
912 iS3 Sport	10008124
912 iS3 Sport	10008125
912 iS3 Sport	10008126
916 iSc3 C24	10008127
916 iSc3 C24	10008128
916 iS3 C24	10008129
916 iS3 C24	10008130
916 iS3 C24	10008131
916 iS3 A	10008132
916 iS3 A	10008133
916 iS3 A	10008134
916 iS3 A	10008135
916 iS3 A	10008136
912 iS3 Sport	10008137
912 iS3 Sport	10008138
912 iS3 Sport	10008139
912 iS3 Sport	10008140
912 iS3 Sport	10008141
912 iS3 Sport	10008142
912 iS3 Sport	10008143
912 iS3 Sport	10008144
912 iS3 Sport	10008145
912 iS3 Sport	10008146
912 iS3 Sport	10008147
916 iS3 A	10008148
916 iS3 A	10008149
916 iS3 A	10008150
916 iS3 A	10008151
916 iS3 A	10008152
916 iS3 A	10008153
916 iS3 A	10008154
916 iS3 A	10008155

Engine type	Engine S/N
916 iS3 A	10008156
916 iS3 A	10008157
912 iS3 Sport	10008158
912 iS3 Sport	10008159
912 iS3 Sport	10008160
912 iS3 Sport	10008161
912 iS3 Sport	10008162
912 iS3 Sport	10008163
912 iS3 Sport	10008164
912 iS3 Sport	10008165
912 iS3 Sport	10008166
912 iS3 Sport	10008167
912 iS3 Sport	10008168
912 iS3 Sport	10008169
912 iS3 Sport	10008170
912 iS3 Sport	10008171
915 iS3 A	10008172
915 iS3 A	10008173
915 iS3 A	10008174
915 iS3 A	10008175
915 iS3 A	10008176
915 iS2 A	10008177
915 iS2 A	10008178
915 iS2 A	10008179
915 iS2 A	10008180
915 iS2 A	10008181
912 iS3 Sport	10008182
912 iS3 Sport	10008183
912 iS3 Sport	10008184
912 iS3 Sport	10008185
912 iS3 Sport	10008186
912 iS3 Sport	10008187
912 iS3 Sport	10008188
912 iS3 Sport	10008189
912 iS3 Sport	10008190
912 iS3 Sport	10008191
912 iS3 Sport	10008192
912 iS3 Sport	10008193
912 iS3 Sport	10008194
912 iS3 Sport	10008195
912 iS3 Sport	10008196
912 iS3 Sport	10008201
912 iS3 Sport	10008202
912 iS3 Sport	10008203
912 iS3 Sport	10008204
912 iS3 Sport	10008205
912 iS3 Sport	10008206
912 iS3 Sport	10008207
912 iS3 Sport	10008208
912 iS3 Sport	10008209
912 iS3 Sport	10008210
912 iS3 Sport	10008211
912 iS3 Sport	10008212
912 iS3 Sport	10008213

Engine type	Engine S/N
912 iS3 Sport	10008214
912 iS3 Sport	10008215