

# SERVICE BULLETIN

## CHECKING OF THE CRANKSHAFT JOURNAL (POWER TAKE OFF SIDE) FOR ROTAX® ENGINE TYPE 912 AND 914 (SERIES)

SB-912-059

SB-914-042

### **MANDATORY**

#### **Symbols used:**

Please, pay attention to the following symbols throughout this document emphasizing particular information.

- ▲ **WARNING:** Identifies an instruction, which if not followed, may cause serious injury or even fatal injury.
- **CAUTION:** Denotes an instruction which if not followed, may severely damage the engine or could lead to suspension of warranty.
- ◆ **NOTE:** Information useful for better handling.

| || A revision bar outside of the page margin indicates a change to text or graphic.

#### **1) Planning information**

##### **1.1) Engines affected**

All versions of the engine type:

- 912 A from S/N 4,410.884 up to S/N 4,410.887 inclusive
- 912 F from S/N 4,412.984 up to S/N 4,412.985 inclusive
- 912 S from S/N 4,924.044 up to S/N 4,924.054 inclusive/4,924.056/4,924.058/4,924.064 up to 4,924.077 inclusive/4,924.081 up to 4,924.084 inclusive/4,924.086
- 914 F from S/N 4,420.965 up to S/N 4,420.970 inclusive/4,420.972 up to 4,420.978 inclusive

- ◆ **NOTE:** Crankshafts with the following serial number (S/N) that were installed in the above-mentioned engines are also affected, if removed:  
S/N 40236/40256/40257/40259/40264/40265/40267/40300/40302/40303/40310/40329/  
40335/40337/40349/40358/40359/40361/40373/40422 up to 40424 inclusive/40426/  
40432/40435/40436/40438 up to 40447 inclusive/40450/40453/40455/40456/40461 up  
to 40464 inclusive/40466/40469/40477/40478/40480/40488/40507

In addition, also affected, all crankshaft set part no. 888164 with crankshaft S/N 40232/40238/40241/40242/  
40245/40248/40428 up to 40430 inclusive/40486, as spare parts or installed at engine repair/general over-  
haul.

##### **1.2) Concurrent ASB/SB/SI and SL**

none

##### **1.3) Reason**

Due to a deviation in the manufacturing process some crankshafts may have a crack formation occur on the power take off side. These cracks can cause a breakage of the crankshaft support bearing and may lead to engine stoppage.

##### **1.4) Subject**

Checking of the crankshaft journal (power take off side) for ROTAX® engine type 912 and 914 (Series).

### 1.5) Compliance

- Required before next flight, but at the latest before 01. April 2012. The checking of crankshaft journal (power take off side) identified by the engine serial number (S/N) listed in section 1.1) must be conducted according to the following instructions in section 3.

◆ NOTE: If a ferry flight is required, a magnetic plug check prior to next flight must be conducted (see latest Maintenance Manual Line Chapter 12-20-00 Check of magnetic plug). If no deviation from normal operation (chips, excess metal filings) is found continued flight is allowed for max. 4 hours in operation, but at latest before 01. April 2012.

▲ WARNING: Non-compliance with these instructions could result in engine damages, personal injuries or fatal injuries.

### 1.6) Approval

The technical content of this document is approved under the authority of DOA ref. EASA.21J.048.

### 1.7) Manpower

Estimated man-hours:

engine installed in the aircraft - - - manpower time will depend on installation and therefore no estimate is available from the engine manufacturer.

### 1.8) Mass data

change of weight - - - none.

moment of inertia - - - unaffected.

### 1.9) Electrical load data

no change

### 1.10) Software accomplishment summary

no change

### 1.11) References

In addition to this technical information refer to current issue of

- Maintenance Manual (MM)

◆ NOTE: The status of Manuals can be determined by checking the table of amendments of the Manual. The 1<sup>st</sup> column of this table is the revision status. Compare this number to that listed on the ROTAX WebSite: [www.rotax-aircraft-engines.com](http://www.rotax-aircraft-engines.com). Updates and current revisions can be downloaded for free.

### 1.12) Other publications affected

none

### 1.13) Interchangeability of parts

not affected

## 2) Material Information

### 2.1) Material - cost and availability

Price and availability and any possible support consideration will be supplied on request by ROTAX® Authorized Distributors or their Service Center.

### 2.2) Company support information

- Shipping cost, down time, loss of income, telephone costs etc. or cost of conversion to other engine versions or additional work, as for instance simultaneous engine overhaul is not covered in this scope and will not be borne or reimbursed by ROTAX®.

### 2.3) Material requirement per engine

parts requirement:

Fig.no.	New p/n	Qty/engine	Description	Old p/n	Application
	-	1	Gasket ring A8x13	950141	crankcase
	-	1	Friction washer VS30	845430	drive gear

### 2.4) Material requirement per spare part

none

### 2.5) Rework of parts

none

### 2.6) Special tooling/lubricant-/adhesives-/sealing compound

Price and availability will be supplied on request by ROTAX® Authorized Distributors or their Service Centers.

parts requirement:

Fig.no.	New p/n	Qty/engine	Description	Old p/n	Application
	-	1	thread bolt M8x50	240880	crankcase
	-	1	puller assy.	877660	propeller gear box
	-	1	puller tool	877540	propeller gear box
	-	50 cc.	LOCTITE 5910	899791	crankcase
	-	5 cc.	LOCTITE 648	899788	hex nut M30

■ CAUTION: In using these special tools observe the manufacturers specifications.

### 3) Accomplishment / Instructions

- ◆ NOTE: Before maintenance, review the entire documentation to make sure you have a complete understanding of the procedure and requirements.

#### Accomplishment

All the measures must be taken and confirmed by at least one of the following persons or facilities:

- ROTAX® -Airworthiness representative
- ROTAX® -Distributors or their Service Centers
- Persons approved by the respective Aviation Authority

▲ WARNING: Proceed with this work only in a non-smoking area and not close to sparks or open flames. Switch off ignition and secure engine against unintentional operation. Secure aircraft against unauthorized operation. Disconnect negative terminal of aircraft battery.

▲ WARNING: Risk of scalds and burns! Allow engine to cool sufficiently and use appropriate safety gear while performing work.

▲ WARNING: Should removal of a locking device (e.g. lock tabs, self-locking fasteners, etc.) be required when undergoing disassembly/assembly, always replace with a new one.

- ◆ NOTE: All work has to be performed in accordance with the relevant Maintenance Manual.

#### 3.1) Check of crankshaft journal (power take off side)

See fig. 1.

1. Lock the crankshaft in accordance with the relevant Maintenance Manual (Line).
  2. Remove the propeller gear box. Use puller assy part no. 877660 or puller tool part no. 877540.
  3. Remove the drive gear in accordance with the relevant Maintenance Manual (Heavy).
  4. Clean and degrease the test area of the crankshaft journal.
  5. Crack detection can be carried out with engine installed in aircraft.
    - ◆ NOTE: Pay attention to manufacturer specifications (crack inspection device).
  6. Unlock the crankshaft to do the check on the entire periphery of the crankshaft.
    - Detailed crack detection in the area (2) of the thread runout using penetration test. Perform this test in accordance to the requirements of the applicable aviation authority in your region for non destructive testing (NDT) and according to DIN EN 571 or equivalent.
    - ◆ NOTE: Protect the crankcase against contamination by the test material.
    - CAUTION: In case of crack or doubt contact your aircraft manufacturer and your nearest authorized ROTAX aircraft engine distributor. The engine must not be taken into operation until the cause has been identified and eliminated.
  7. If no cracks can be found, then the reassembly has to be conducted in accordance with following steps:
    - Lock the crankshaft in accordance with the relevant Maintenance Manual (Line).
    - Clean and degrease crankshaft journal, threads and splines.
    - Install the drive gear with a new friction washer in accordance with the relevant Maintenance Manual (Heavy).
    - Clean the sealing surface of crankcase and gear cover.
    - Install the propeller gear box.
    - Remove locking pin of crankshaft in accordance with the relevant Maintenance Manual (Line).
- Restore aircraft to original operating configuration.
  - Connect negative terminal of aircraft battery.

### **3.2) Test run**

Conduct test run including ignition check and leakage test.

### **3.3) Summary**

These instructions (section 3) have to be conducted in accordance with compliance in section 1.5.  
The execution of the mandatory Service Bulletin must be confirmed in the logbook.

Approval of translation to best knowledge and judgement - in any case the original text in German language and the metric units (SI-system) are authoritative.

#### 4) Appendix

the following illustrations/drawings should convey additional information:

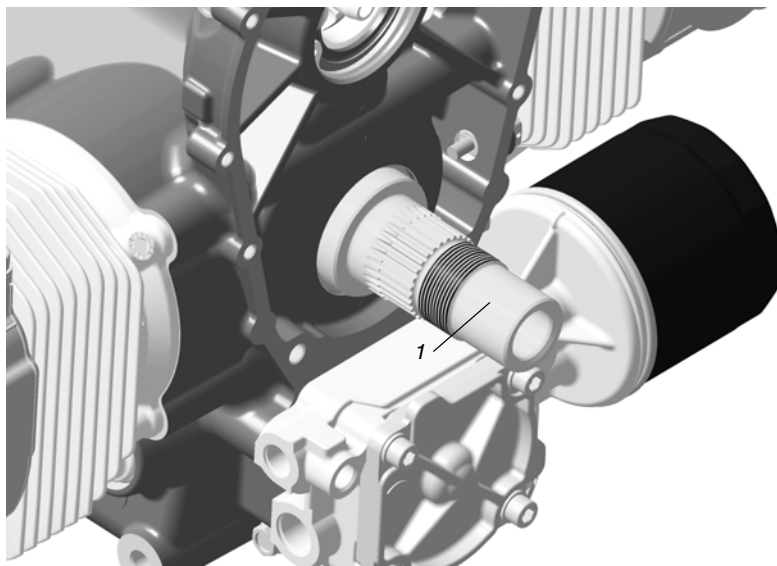

- 1 crankshaft
- 2 detailed crack detection

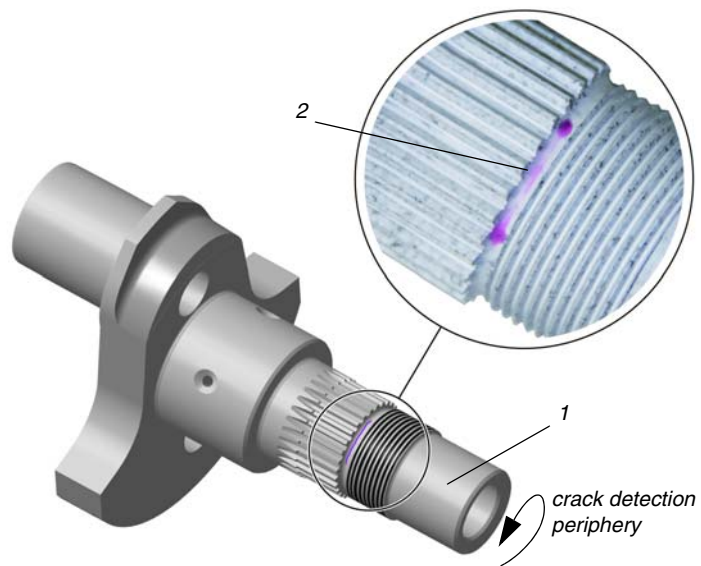

06484, 06485

**Fig. 1**  
**crankshaft journal**

- ◆ **NOTE:** The illustrations in this document show the typical construction. They may not represent full detail or the exact shape of the parts which have the same or similar function. Exploded views are **not technical drawings** and are for reference only. For specific detail, refer to the current documents of the respective engine type.