



ROTAX ULTRALIGHT ENGINE TYPE 503 FREE AIR (FA)

1) GENERAL

1.1. In the course of further development the cylinder head fixation of engine type 503 UL FA has been modified. This modification is to reduce the stress concentration of cylinder studs and to avoid occasionally experienced breaking of the studs.

2) PARTS CONCERNED

2.1. All 8 shims 8,4 are replaced by 4 mm high cone sleeves (1), part no. 847 475.

The cone sleeve has to be fitted with the cone side on top (for recognition marked by a groove, see illustration).

2.2. 4 distance nuts M8 x 37 are replaced by 4 distance nuts (2) M8 x 33, part no. 242 660.

2.3. The studs remain unchanged.

3) This modification was introduced with engine serial number 3,717.645.

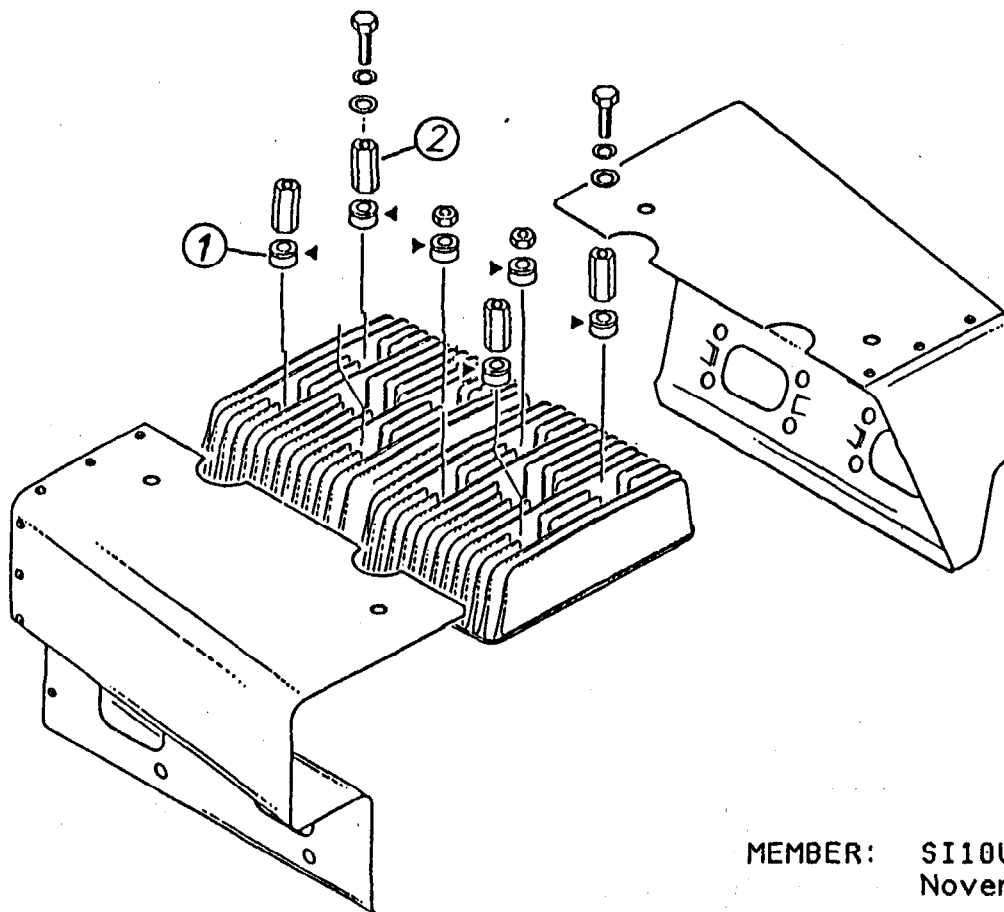

MEMBER: SI10ULE
November 1987