



Ignition unit of ROTAX engine 912 UL

1) Matter:

As known from experience, inadequate ground connection could arise between stator and ignition housing on the engine type 912 UL.

2) Concerned:

All engines up to engine no. 4,005.330. On all subsequent engines, measures have been taken at Rotax already.

3) Remedy:

Improve ground connection between stator and ignition housing. This can be carried out with engine installed in the aircraft.

Disconnect battery. No need to withdraw magneto housing ① with magneto ring. Remove at least 2 of the 4 Allen screws ③ and lock washers for stator attachment via the openings ② in the magneto housing.

■ **ATTENTION:** Make absolutely sure that no foreign matter (lock washer or screws) will stick to the magneto ring.

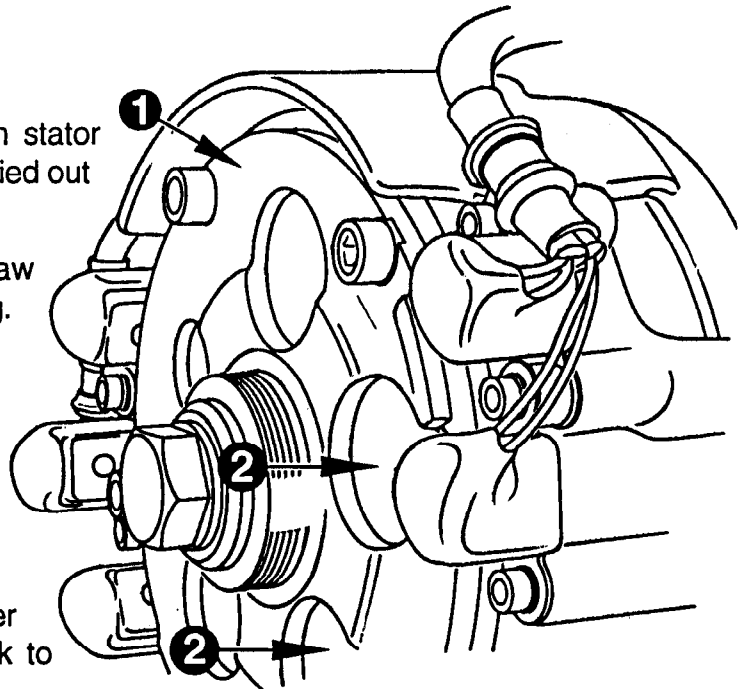

Use spot-facing cutter ④ or similar tool to machine contact face ⑤ on stator for the screws ③ removed. It is advisable to grease cutting tool to collect chips on cutter and not on magneto ring.



Refit screws M5 along with lockwasher and tighten to 6 Nm. To ensure lasting ground connection treat contact faces for screws with Lithium-base grease.

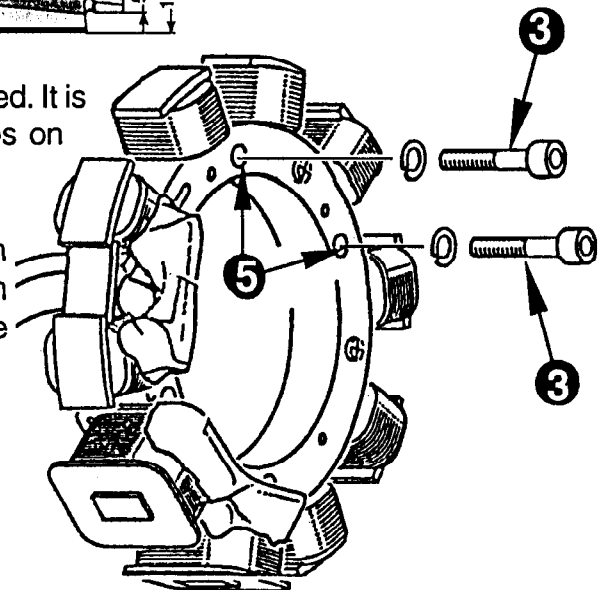

Reconnect battery and carry out ignition check.