

SERVICE INSTRUCTION

INSTALLATION INSTRUCTION OF UL REDUCTION GEARBOX TYPE „C“ AND „CL“ SI-09-1994 R2

MANDATORY

Repeating symbols:

Please, pay attention to the following symbols throughout this document emphasizing particular information.

- ▲ **WARNING:** Identifies an instruction, which if not followed, may cause serious injury or even death.
- **CAUTION:** Denotes an instruction which if not followed, may severely damage the engine or could lead to suspension of warranty.
- ◆ **NOTE:** Information useful for better handling.

1) Planning information

1.1) Engines affected

All versions of the engine type:

- 503 UL DCDI (Series)
- 582 UL DCDI mod. 90/99 (Series)
- 618 UL DCDI (Series)

1.2) Concurrent ASB/SB/SI and SL

Further to this Service Instruction the following additional Service Instructions must be observed and complied with:

- SI-2ST-004 Running Modifications on ROTAX® 2-Stroke UL Aircraft engine
- SI-06-1998 Amendment on propeller gearbox type "C" and "E" for two- stroke engines
- SI-06-1996 Modifications on reduction gearbox "C" and "E"

1.3) Subject

Installation instruction of UL reduction gearbox type "C" and "CL"

1.4) Approval

The technical content of this document is approved under the authority of MOT, DOA Nr. MOT. JA. 03.

1.5) Manpower

Estimated man-hours:

Engine removed from the aircraft 1 h per unit.

1.6) Mass data

Change of weight see relevant Installation Manual (IM)

Moment of inertia see relevant Installation Manual (IM)

1.7) References

In addition to this technical information refer to current issue of

- Installation Manual (IM)
- Maintenance Manual (MM)
- Repair Manual (RM)
- all relevant Service Instructions (SI)

2) Material Information

2.1) Material - cost and availability

Price and availability will be supplied on request by ROTAX[®] Authorized Distributors or their Service Center.

2.2) Special tooling/lubricant-/adhesives-/sealing compound - Price and availability

Fig.no.	p/n	Qty/engine	Description	Old p/n	Application
(1; 2)	n.a.	NB	DEGREASING AGENT		U
(2; 3; 4; 5; 6)	899785	NB	LOCTITE 221 VIOLET		A
(9; 11)	n.a.	NB	MULTIPURPOSE GREASE LZ		N
(8)	297433	NB	MOLYKOTE G-N; SLIDE PASTE		M

3) Accomplishment / Instructions

Accomplishment

- ROTAX® -Distributors or their Service Centers
- *Persons with type-specific training (applicable only for non-certified engines)*

- ▲ **WARNING:** Proceed with this work only in a non-smoking area and not close to sparks or open flames. Switch off ignition and secure engine against unintentional operation. Secure aircraft against unauthorized operation. Disconnect negative terminal of aircraft battery.
- ▲ **WARNING:** Risk of scalds and burns! Allow engine to cool sufficiently and use appropriate safety gear while performing work.
- ▲ **WARNING:** Should removal of a locking device (namely lock tabs, self-locking fasteners) be required when undergoing disassembly/assembly, always replace with a new one.
- ◆ **NOTE:** All work has to be performed in accordance with the relevant Maintenance Manual.
- ◆ **NOTE:** Installation of the gear box by qualified, trained and authorized (by ROTAX) persons only. Careful installation and attention to stated instructions warrant trouble-free operation.

3.1) Instructions

➤ **On C-type gearbox only:**

Clean taper of flywheel (2) and crankshaft (1) as well as threaded hole in crankshaft end with suitable degreasing agent. (see fig. 1)

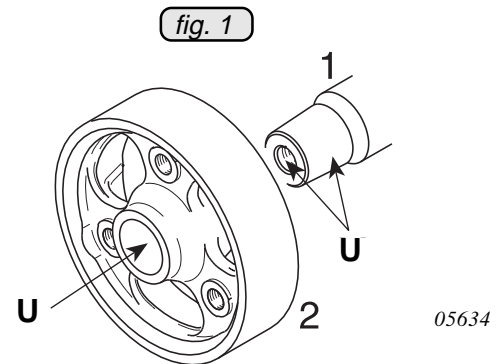

➤ **On CL-type gearbox only:**

Attachment of coil kit on adapter housing (3a) with 3 Allen screws M5x30 (3b). Tightening torque 6 Nm (50 in.lb.) (see fig. 2).

◆ **NOTE:** Always use Allen key with guide pin! Secure Allen screws with LOCTITE 221 (A).

◆ **NOTE:** Push cable protection hose right on to the coils and fit the split cable grommet.

Join magneto flywheel (2a) and adapter housing (3a) (see fig. 2).

▲ **WARNING:** The magnetic field will strongly pull the magneto flywheel on to adapter housing. Danger of injury (see fig.2)!

Clean taper of flywheel (2a) and crankshaft as well as threaded hole in crankshaft end (1) with suitable degreasing agent (U) (see fig. 2).

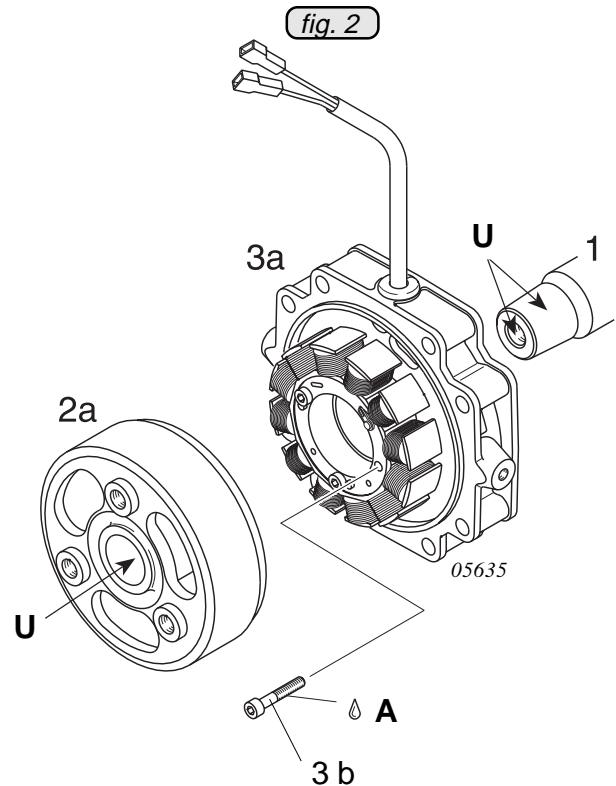

- Lock crankshaft with locking pin p/n 876640 (4) (see fig. 3; 4).

- With **C**-type gear box fit flywheel (2) and on **CL**-type generator assembly (3a) along with flywheel on P.T.O. end of crankshaft (1) and attach with hex. hd. screw 1/2-20UNFx30 (5) on **C**-type and with 1/2- 20UNFx38 (5a) on **CL**-type and washer (6) (chamfered side towards screw) and tighten with **80 Nm** (708 in.lb.) (see fig. 3; 4)

▲ **WARNING:** Secure hex. hd. screw with LOCTITE 221 (A).

- Fit pre-assembled rubber coupling (7) on fly wheel for **C**-type gear box or flywheel-generator assy for **CL**-type gearbox and attach with three Allen screws M10x45 (8) and flat-sided washer (9). By utilizing reworked fork spanner 17 A/F secure washer from turning, thus preventing to lock up any stress in rubber coupling. Tighten Allen screws with 40 Nm (354 in.lb.) (see fig. 5; 6)

◆ **NOTE:** Always use Allen key with guide pin.

▲ **WARNING:** Secure Allen screws with LOCTITE 221 (A).

- Don't forget to remove clamp strap (10) from rubber coupling after assembly is complete (see fig. 5; 6).

- After removal of the two Allen screws M6x30 (3) separate gear cover (11) and gear housing by careful tapping on assigned lug (B) with a mallet (see fig. 7).

C-Gearbox

CL-Gearbox

fig. 3

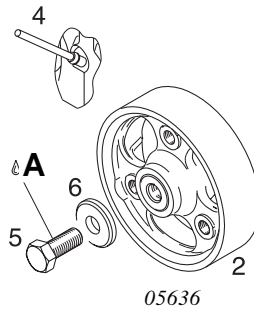

fig. 4

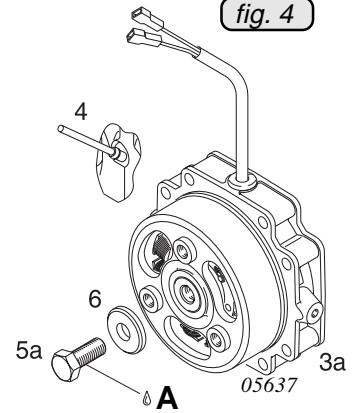

fig. 5

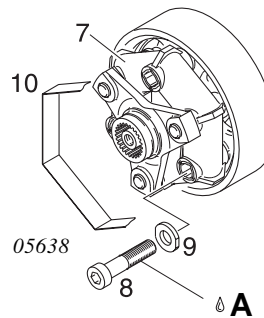

fig. 6

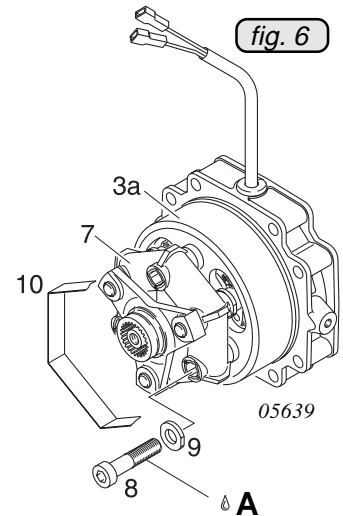
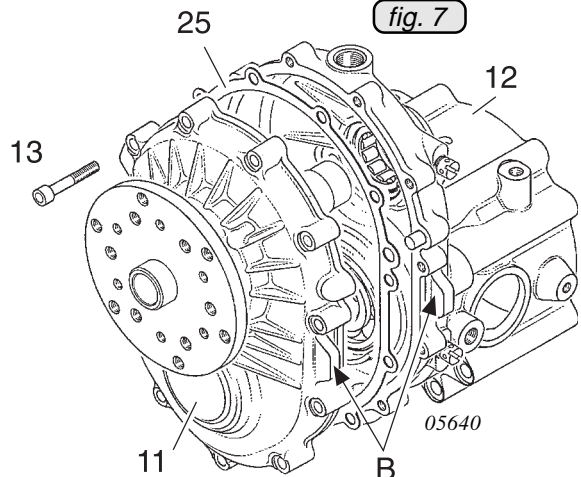
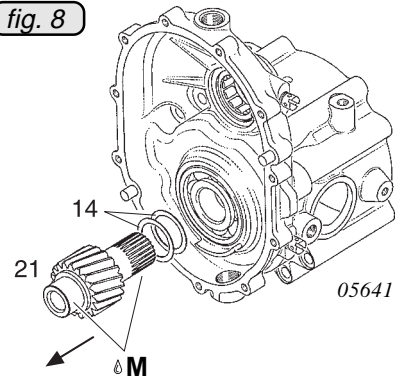

fig. 7



- Carefully remove gasket (25) and place on clean pad (see fig. 7).

fig. 8



- Remove pinion shaft (21) along with shims (14). Apply Molykote G-N (M) to bearing seats and tooting (see fig. 8).

- Remove the 4 inserted plastic plugs (17) and apply grease (N) to prop shaft journal (18), to tooting of coupling flange (20) and to inside of roller bearing (19) (see fig. 9).

fig. 9

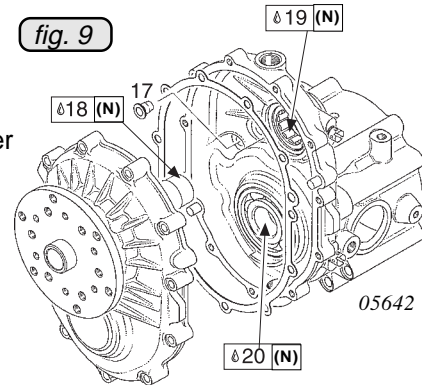

- Fit gear housing (12) in proper position (see fitting position, page 5) (see fig. 10)

fig. 10

- Carefully slide pinion shaft (21) along with shims (14) into tooting of coupling flange (see fig. 10)

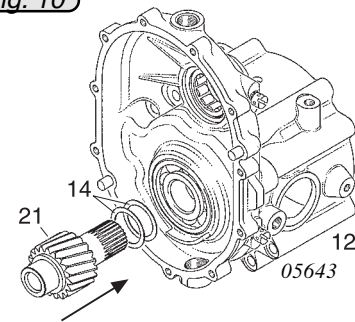

- Grease face of the 8 hex. collar screws M8x90 (22) on C-type and M8x119 (22) on CL-type and attach gear housing (12) to engine by tightening the screws in the shown sequence with 24 Nm (212 in.lb.) (see fig. 11; 12)

fig. 11

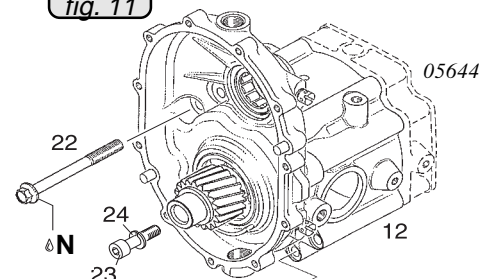

◆ NOTE: Lubrication of screw faces prevents seizing.

- Attach pinion shaft (21) to coupling (7) with Allen screw M8x35 (23) and lock washer (24) tightened with 24 Nm (212 in.lb.) (see fig. 11; 12)

fig. 12

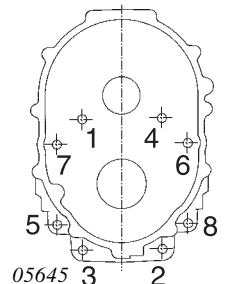

- Place dry gasket (25) into position and fit gear cover (11) carefully.

■ CAUTION: Ensure easy fitting of gear cover. Gasket (25) to be fitted in dry condition only (see fig. 13).

fig. 13

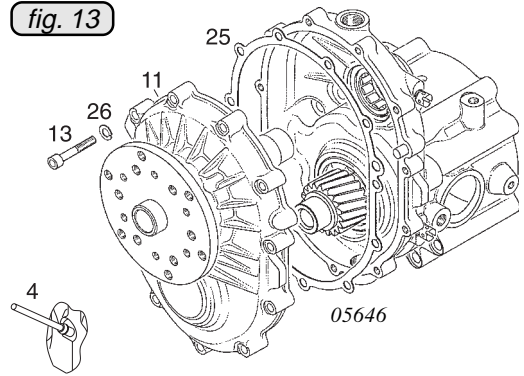

- Join gear cover and housing with 11 Allen screws M6x30 (13) and lock washers (26) and tighten screws crosswise with 10 Nm (90 in.lb.) (see fig. 13)
- Remove crankshaft locking pin (4).

- The gear box can be installed in two basic positions: SZ = upright with prop shaft towards cylinder head. SS = inverted with prop shaft towards engine base (see fig. 14)

According to position of gear box, fit magnetic plug and sealing ring (27) (tightening torque 24 Nm = 212 in.lb.) and vent screw with sealing ring (28) (tightening torque 6 Nm = 53 in.lb.) (see fig. 14; 15)

■ CAUTION: Use suitable oil only!
Recommended oil: SAE 140 EP or SAE 85 W - 140EP (API-Classification GL 5 or 6).

fig. 14

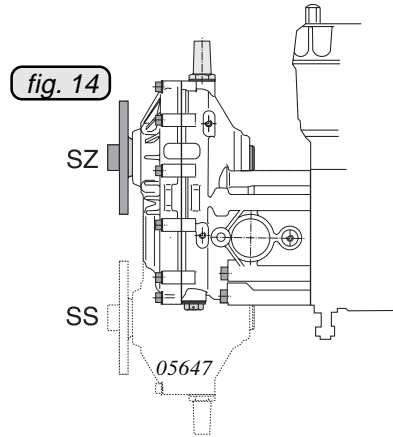

- Refill capacity:
gear box position „SZ“ c. 200 cm³ (0,42 liq.pt)
gear box position „SS“ c. 120 cm³ (0,25 liq.pt)

- Generally fill gearbox with oil-, until oil emerges at the respective **lower oil level plug (29)** (see fig. 16).

■ CAUTION: The two large ventilation holes (30) on both sides of gear housing have to remain always open to warrant dissipation of heat.

fig. 15

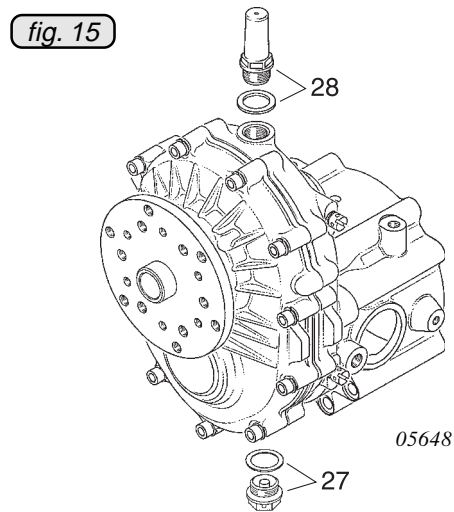

- Safety- wire vent screw, oil level plugs and drain plug. (see fig. 16)
- With the installation of an CL gear box the tapped holes for radiator support (31) are transferred from gear box housing to adapter housing (see fig. 16).

■ CAUTION: At trial run check tightness with out fail.

- The propeller flange (32) is furnished with 6 tappings M6 and 6 holes each of 6,5 mm and 8,2 mm dia., but screws are not in the supply scope (see fig. 15).

■ CAUTION: With use of ROTAX® gear box type “C” or “E” (EL) the moment of inertia of the propeller must not be in excess of **6000 kgcm²**. Enquire for moment of inertia and have it confirmed by the manufacturer of propeller.

fig. 16

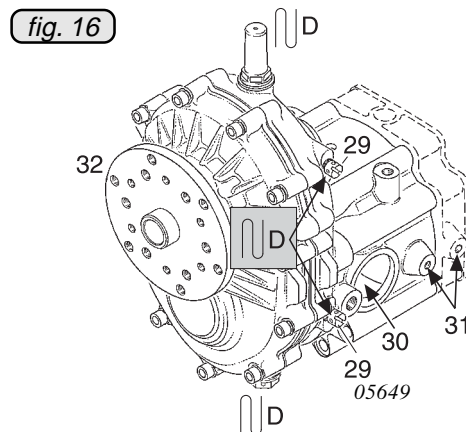

- For ROTAX® part numbers consult spare parts list of the respective engine type.

3.2) Electric equipment

► External generator 12V/220W

This generator supplies 220W at 6000 r.p.m. and is connected parallel into the circuit. (see wiring diagram, illustration shows breakerless dual ignition).

Power supply via rectifier-regulator and 20A fuse for charging the battery and to feed DC consumers.

- ◆ NOTE: The effective voltage with rectifier-regulator p/n **866080** is 13,5 - 14,5 Vand requires a 1 amp minimum electrical load for proper operation. If a battery is used, it has to be capable to absorb at least 1 amp. continuous charging load, even with battery full. When using the 3-phase rectifier-regulator p/n **264870** no minimum load is required.

- Restore aircraft to original operating configuration.
- Connect negative terminal of aircraft battery.

3.3) Test run

Conduct test run including ignition check and leakage test.

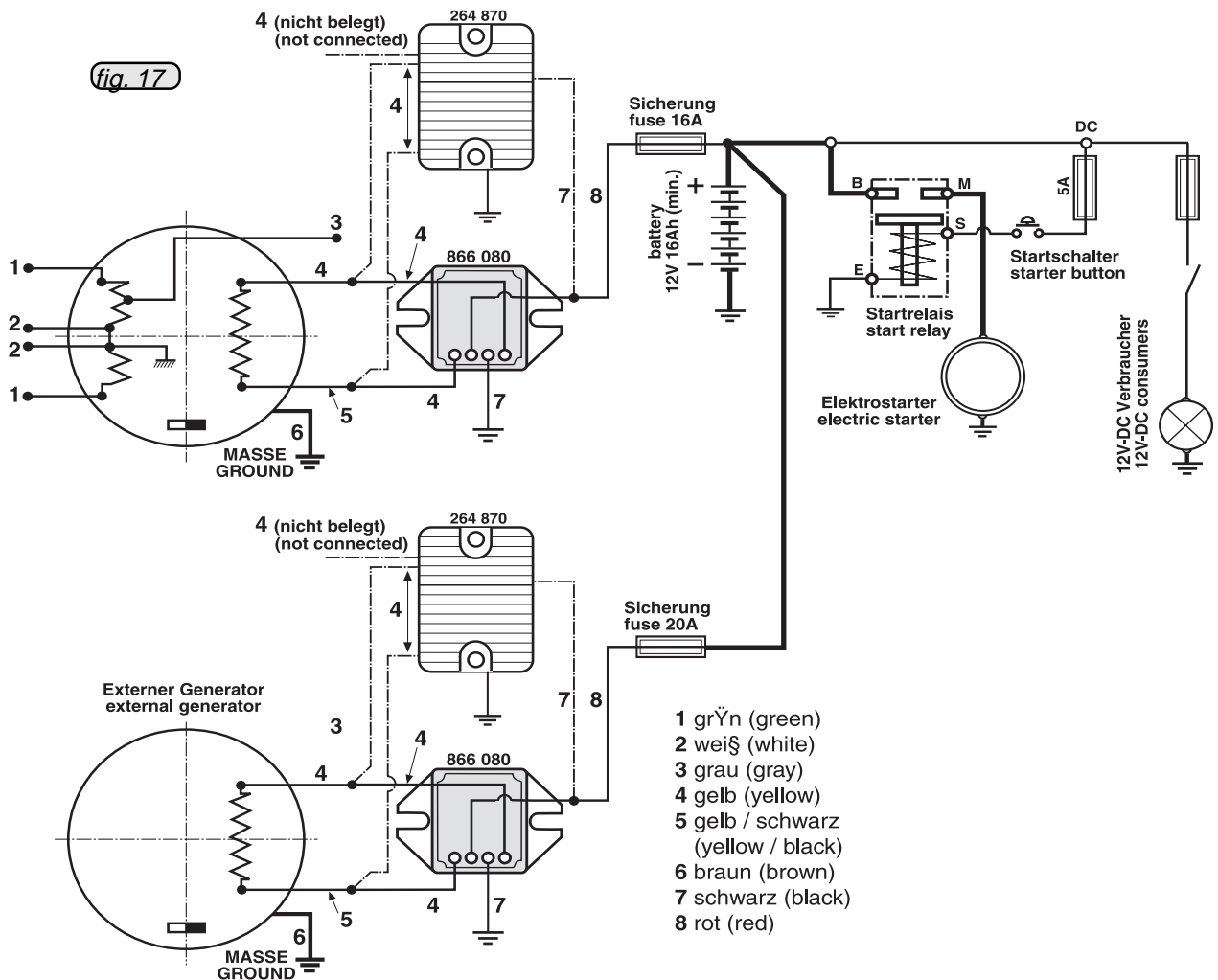

05650

- ◆ NOTE: The illustrations in this document show the typical construction. They may not represent full detail or the exact shape of the parts which have the same or similar function. Exploded views are **not technical** drawings and are for reference only. For specific detail, refer to the current documents of the respective engine type.