

SERVICE INSTRUCTION

Purging of lubrication system for ROTAX® Engine Type 916 iSc B, 915 i A, 915 i B, 912 i, 912 and 914 (Series)

ATA System: 79-00-00 Lubrication system

1) Planning information

To obtain satisfactory results, procedures specified in this publication must be accomplished with accepted methods in accordance with prevailing legal regulations.

BRP-Rotax GmbH & Co KG cannot accept any responsibility for the quality of work performed in accomplishing the requirements of this publication.

1.1) Applicability

All versions of ROTAX® engines types:

Engine type	Serial number
916 iSc B	all
915 i A (Series)	all
915 i B (Series)	all
912 i (Series)	all
912 (Series)	all
914 (Series)	all

1.2) Concurrent ASB/SB/SI and SL

In addition to this Service Instruction the following Service Instructions must be observed and complied with:

- SI-912 i-005/SI-912-010/SI-914-011, title "Oil change", current issue.
- SI-916 i B-001/SI-915 i-001/SI-912 i-001/SI-912-016/SI-914-019, title "Selection of suitable operating fluids", current issue.

1.3) Reason

ROTAX® was informed of a limited number of engine failures in the field resulting from a lack of proper oil purging after the engine had been first installed and /or the engine had been re-worked. This Service Instruction should help to make sure that the engines do not suffer such engine failures in the field. As air can be trapped in the valve tappets and cause valve train failure it is very important to complete these instructions in their entirety.

1.4) Subject

Purging of lubrication system for ROTAX® engine type 916 iSc B, 915 i A, 915 i B, 912 i, 912 and 914 (Series).

1.5) Compliance

These inspections have to be performed

- before first engine run,
- after re-installation (e.g. after overhaul),
- after lubrication system opened and drained during maintenance work (e.g. removal of oil pump, oil cooler or suction line).

SERVICE INSTRUCTION

NOTE: Not affected are the removal and replacement of components that do not drain the oil pressure galleries.



Non-compliance with these instructions could result in engine damages, personal injuries or death.

These maintenance instructions shall be considered at any maintenance events, retrofitting, repair and overhaul.

1.6) Approval

The technical content of this document is approved under the authority of the DOA ref. EASA.21J.048.

1.7) Labor time

Estimated labor hours:

Engine installed in the aircraft - - - labor time will depend on airframe installation and therefore no estimate is available from the engine manufacturer.

1.8) Mass data

Change of weight - - - none.

Moment of inertia - - - unaffected.

1.9) Electrical load data

No change.

1.10) Software modifications

No change.

1.11) References

In addition to this technical information refer to current issue of

- Operators Manual (OM)
- Installation Manual (IM)
- all relevant Service Bulletins (SB)
- all relevant Service Instructions (SI)
- Maintenance Manual Line (MML)
- Maintenance Manual Heavy (MMH)

NOTE: The status of the Manuals can be determined by checking the table of amendments. The 1st column of this table shows the revision status. Compare this number to that listed on the ROTAX website:
www.flyrotax.com. Updates and current revisions can be downloaded for free.

1.12) Other Publications affected

None.

1.13) Interchangeability of parts

Not affected.

d06776.fm

SERVICE INSTRUCTION

2) Material Information

2.1) Material

Price and availability will be provided on request by ROTAX® Authorized Distributors or their independent Service Centers.

2.2) Company support information

None.

2.3) Material requirement per engine

parts requirement:

Fig.no.	Part no.	Qty/ engine	Description	Application
	881920	1	O-ring set	valve cover
consisting of:				
	250285	4	O-ring 105x2.5	valve cover
	430205	4	O-ring 6.4x1.8	valve cover

NOTE: Additional new parts are only necessary if wear was found in the engine valve train. Order only the current need in accordance with Illustrated Parts Catalog (IPC), current issue.

2.4) Material requirement and spare part

None.

2.5) Rework of parts

None.

2.6) Special tooling/lubricants- /adhesives- /sealing compounds

None.

SERVICE INSTRUCTION

3) Accomplishment/Instructions

- ROTAX® reserves the right to make any amendments to existing documents, which might become necessary due to this standardization, at the time of next revision or issue.

NOTE: Before maintenance, review the entire documentation to make sure you have a complete understanding of the procedure and requirements.

Accomplishment

All measures must be implemented and confirmed by at least one of the following persons or organizations:

- ROTAX® - Airworthiness representatives
- ROTAX® - Authorized Distributors or their independent Service Centers
- Persons approved by the respective Aviation Authority
- Persons with approved qualifications for the corresponding engine types. Only authorized persons (iRMT, Level minimum 9-Series Service) are entitled to carry out this work.
- Persons with type-specific training

NOTE: All work has to be performed in accordance with the relevant Maintenance Manual.

General

All general inspection, maintenance and repair has to be carried out e.g. in accordance with relevant Advisory Circular AC 43.13 from FAA.

Advisory Circular

This Manual "Advisory Circular" AC describes maintenance methods, techniques and practice. These are recognized and authorized for inspection and repairs in non-pressurized areas for which there are no separate maintenance and repair instructions.

Safety notice



WARNING

Identifies an instruction which, if not followed, may cause serious injury or even fatal injury.



CAUTION

Identifies an instruction which, if not followed, may cause minor or moderate injury.

NOTICE

Identifies an instruction which, if not followed, may severely damage the engine or could void any warranty.

ENVIRONMENTAL NOTE

Environmental notes give you tips on environmental protection.

NOTE: Indicates supplementary information which may be needed to fully complete or understand an instruction.

3.1) Instruction - related information

3.1.1) Purging of oil system

See Fig.1.

- Verify that oil tank connections are connected correctly and secured, and that the oil cooler (if fitted) is in the suction line (return line)(1) between the oil tank and the oil pump inlet. Verify that

d06776.fm

SERVICE INSTRUCTION

the oil tank is filled up to the maximum level (to the top of the flat portion of the dipstick). Additional oil (up to 0.5 litre) may be added to the tank for the purpose of this procedure.

NOTE: Consult appropriate engine Installation Manual for diagrams to identify oil tank and oil pump connections. Older engines may be equipped with oil tanks that have oil ports in different locations.

NOTICE

Incorrectly connected oil lines to the oil tank or to the engine will result in severe engine damage.

Step	Procedure
1	Disconnect oil return line(s) (2) from the oil tank (915 i and 916 iSc B two return lines). NOTE: Do not disconnect the turbo scavenge return line.
2	Place the free end (915 i and 916 iSc B with two free ends) (3) of the return oil line into a suitable container (4) below the engine. NOTE: This step is a cleanliness precaution. Typically, during the purging procedure, oil does not come out from the hoses.
3	Plug open connection (5) (915 i with two connections) on oil tank with suitable air tight cap or plug.
4	Remove all of the spark plug connectors from the spark plugs.
5	For easier rotation of engine remove one spark plug from each cylinder.

NOTICE

Prevent entering of foreign substance through spark plug hole.

Step	Procedure
6 Optional:	This step assists in the purging procedure but may be skipped if compressed air is not available. The procedure may take longer without air pressure. Using a compressed air line, pressurize the oil tank through its vent nipple (6) (on the neck of the tank). Adjust the compressor outlet regulator so that the air line pressure is between 0.4 (5.8 psi) and 1 bar (15 psi). Do not exceed 1 bar (15 psi).

NOTE: The oil tank bayonet cap is not pressure-tight, some air can escape.

WARNING

Non-compliance can result in serious injuries or death!
Do not remove oil tank or cover before ensuring that air pressure has been completely released from the tank.

The pressure in the oil tank has to be maintained during the following steps

NOTE: Do not use the starter for this purpose. Fit propeller and use it to turn the engine.

NOTICE

The oil tank may become empty and as result introduce air into the oil system. Pay attention to the oil level and fill tank as required.

SERVICE INSTRUCTION

Step	Procedure
7	Turn the engine by hand in direction of normal rotation until the first pressure indication on the oil pressure gauge of engine instrumentation in the cockpit. Normally this will take approx. 20 turns. Depending on installation it may take up to 60 turns.
8	Stop the pressurization. Allow air pressure to bleed off.
9	Remove the cap(s)(5) from the oil tank and reconnect the engine oil return line(s) (5) (2) to the tank. <div style="background-color: #0070C0; color: white; padding: 2px; display: inline-block;">NOTICE</div> Ensure that the suction oil line (1) and oil return line(s) (2) are connected to the proper fittings on the oil tank. If the oil lines from the engine to the oil tank are incorrectly connected, severe engine damage may result.

Step	Procedure
10	Re-fit the spark plugs. Restore aircraft to original operation condition.
11	Residual oil may have accumulated in the crankcase. Return it to the oil tank by following the oil level check procedures in the relevant Operators Manual (OM).
12	Fill the oil in the tank up to the full mark on the dipstick.

WARNING

Non-compliance can result in serious injuries or death!
 Carefully check all lubrication system connections, lines and clamps for leaks and security.

ENVIRONMENTAL NOTE

Protect their environment. Observe to bury no oil!
 Dispose of oil in an environmentally friendly manner.

3.1.2) Purging of turbocharger lubrication system on ROTAX® 914, 916 iSc B and 915 i (Series)

WARNING

Non-compliance can result in serious injuries or death!
 Observe the appropriate safety precautions. Make sure that there are no foreign items including tools in the engine compartment. Secure aircraft to the ground appropriately and place chocks under the wheels. Secure propeller zone to warrant safety for persons and property. Be sure to approach only from engine side of propeller. Permanently supervise engine operation from a secure position. The cockpit must be occupied during the testing by a licensed pilot or an authorized person to conduct test runs of an aircraft.

Following steps need to be performed:.

Step	Procedure
1	Disconnect turbo oil return line from the oil tank and route the line to a separate container.
2	Start the engine in accordance to the relevant Operators Manual (OM).

d06776.fm

SERVICE INSTRUCTION

Step	Procedure
3	Observe oil pressure and oil flowing back.
4	Fit the turbo sump oil return line (7) on oil tank. See latest Maintenance Manual Heavy (MMH) for the respective engine type or instruction of aircraft manufacturer for ROTAX® 916 iSc B and 915 i Series.

To verify operation of the turbo charger oil circuit detach the turbo sump oil return line (7) on the oil tank (e.g. banjo bolt M10x1x19) and route the line to a separate container. Start the engine in accordance to 3.2 and observe if oil is being returned back.

If oil is not flowing back within 10 sec. stop the engine immediately and find the trouble. Repeat previous steps until proper oil flow is observed. The engine must not be operated before rectification.

- Restore aircraft to original operating configuration.

3.2) Warming up period

NOTICE

Before commencing with the warming up period, the following job tasks need to be performed.

Step	Procedure
1	Ensure that all engine and actuation system like carburetor actuation, cooling system, ignition switch and propeller are installed and tested O.K. according to specifications of aircraft manufacturer.

NOTE: At a new installation or modifications to installation do not start the engine before all installation checks are finished.

Step	Procedure
2	Connect negative terminal of aircraft battery.
3	Start engine and observe oil pressure.

NOTICE

If oil pressure does not raise within 5 sec. after engine start, shut engine off. Do not start engine before lubrication system is checked and purging procedure is repeated.
 Repeated test starts with no indicated oil pressure will severely damage the engine.

Step	Procedure
4	Run engine for about 2 min. at 2000 rpm. Then warm up engine at 2200 to 2500 rpm depending on ambient temperature until an oil temperature of 50 °C (122 °F) is reached.
5	Check temperature and pressure values.

d06776.fm

SERVICE INSTRUCTION

Step	Procedure
6	Stop engine and secure aircraft against unauthorized operation.
7	Check oil level as per operators manual and refill as necessary. Refill oil level in the tank to max. mark. Do not overfill, otherwise oil would exit through vent hole during operation. At oil level check the max. mark must not be exceeded.

3.3) Inspect the hydraulic valve tappet for correct purging

See Figure 3.



WARNING

Risk of burns and scalds.
 Hot engine parts. Always allow engine to cool down to ambient temperature before starting work.

The following check procedure describes the correct method for checking the hydraulic valve tappets.

Step	Procedure
1	Remove valve cover on cylinder 1.
2	Turn crankshaft in direction of normal rotation so that cylinder 1 is set to top dead center (both valves are closed).
3	Push down the rocker arm on the push-rod side with a force (F) of around 70 N (15.74 lb-force) for about 3 seconds. You can use a belt tester, for example, to check approximately how much force is being exerted. Repeat on other rocker arms.
4	Check distance between rocker arm and valve contact surface. Max. allowable distance 0.5 mm (0.02 in.).

NOTICE

If it is possible to push the valve tappets further than this limit, perform an additional engine run for about 5 min. at 3500 rpm after refitting the valve covers. To get the hydraulic valve tappets primed, this process can be repeated another 2 times.

Step	Procedure
5	Repeat on all other cylinders.

3.4) Replacement of components

If a hydraulic valve tappet still malfunctions after several engine runs, it must be replaced and the valve spring support must be inspected for wear.

All work has to be performed in accordance with the latest Maintenance Manual for the respective engine type.

SERVICE INSTRUCTION

Step	Procedure
1	<p>Inspect valve spring support (8). Measure the wear referring to the reference surface (inner area of valve spring support) in radial direction (9) to outer side with a dial gauge. Value $t = \max. 0.04 \text{ mm (0.0016in.)}$. See Fig. 4. An exceeding of $\max. 0.04 \text{ mm (0.0016 in.)}$ is not acceptable.</p> <p>NOTE: The valve spring support indicates a possible malfunction of valve train caused by incorrectly or insufficiently purged hydraulic valve tappets. At standard conditions no wear is visible even after a long time of operation. If the visual inspection shows some wear on the valve spring support surface, measure the actual wear with a dial gauge.</p>

If the valve spring support indicates wear, replace valve spring retainer, valve spring support, both valve cotters, valve and hydraulic valve tappet. Additionally perform a detailed visual inspection of relevant valve train components of push rod, rocker arm and valve spring for abnormal wear condition.

Carry out further warm up and inspection of the hydraulic valve tappets in compliance with section 3.2 and 3.3 until all 8 hydraulic valve tappets are hard and the max. allowable distance is not exceeded.

3.5) Test run

Conduct test run.



See Chapter 12-20-00 of the latest Maintenance Manual Line (MML) for the respective engine type.

3.6) Summary

These instructions (section 3) have to be followed in accordance with the deadlines specified in section 1.5.

The execution of the Service Instruction must be confirmed in the logbook.

NOTE: Work on EASA certified parts might affect the EASA Form 1 and does require appropriate documentation by authorized persons. Repairs must be entered into the engine logbook and also do apply for the EASA Form 1.

A revision bar outside of the page margin indicates a change to text or graphic.

Translation into other languages might be performed in the course of language localization but does not lie within ROTAX' scope of responsibility.

In any case the original text in English language and the metric units are authoritative.

3.7) Inquiries

Inquiries regarding this Service Instruction should be sent to the ROTAX® Authorized Distributor of your area.

A list of all ROTAX® Authorized Distributors or their independent Service Centers is provided on www.flyrotax.com.

d06776.fm

SERVICE INSTRUCTION

4) Appendix

The following drawings should convey additional information:

- 1 suction oil line
- 2 oil return line(s)
- 3 free end
- 4 suitable container
- 5 cap or plug
- 6 vent nipple
- 7 oil return line

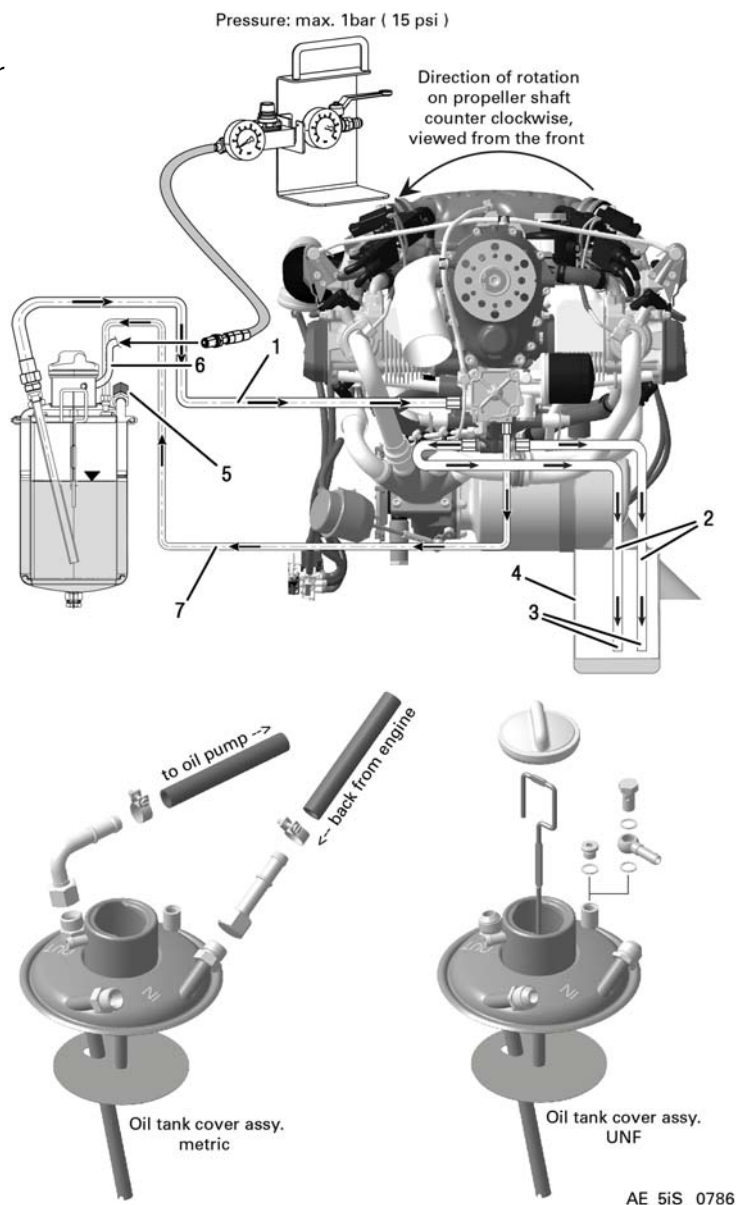

Fig. 1
Purging of oil system (916 iSc B and 915 i Series)

d06776.fm

SERVICE INSTRUCTION

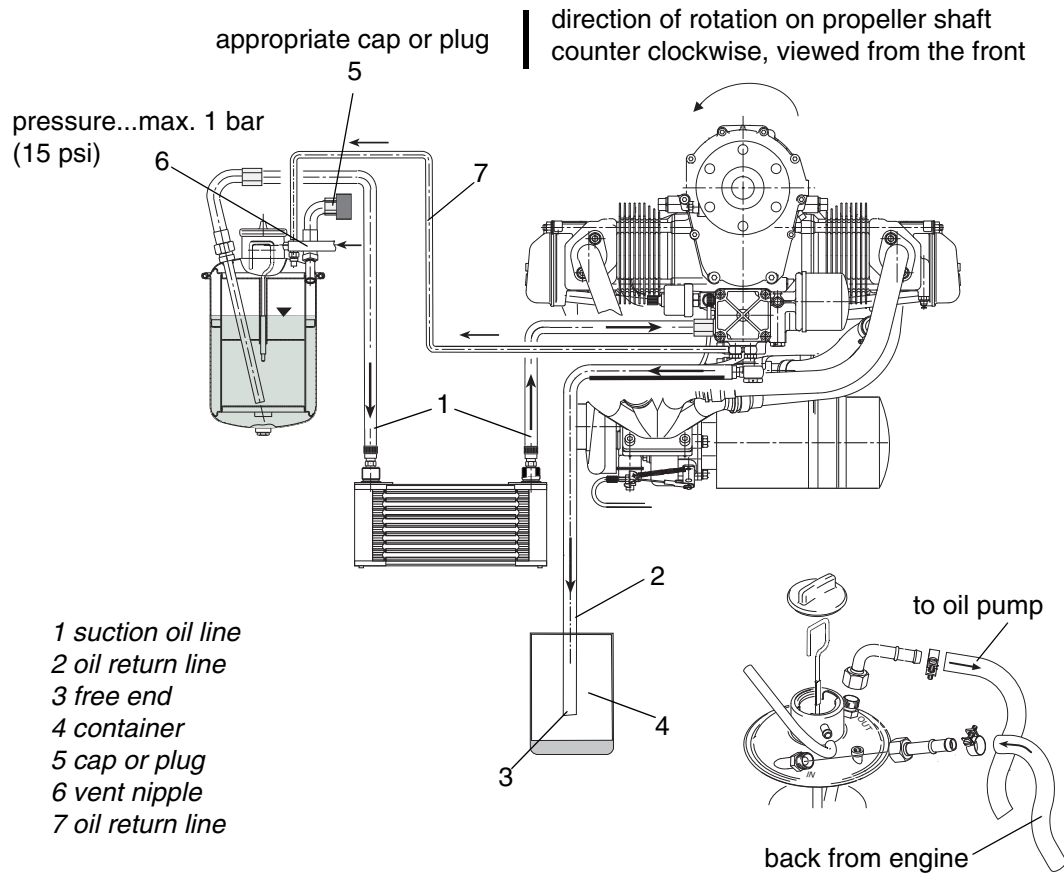

Fig. 2
Purging of oil system (914 Series)

05449,05451

SERVICE INSTRUCTION

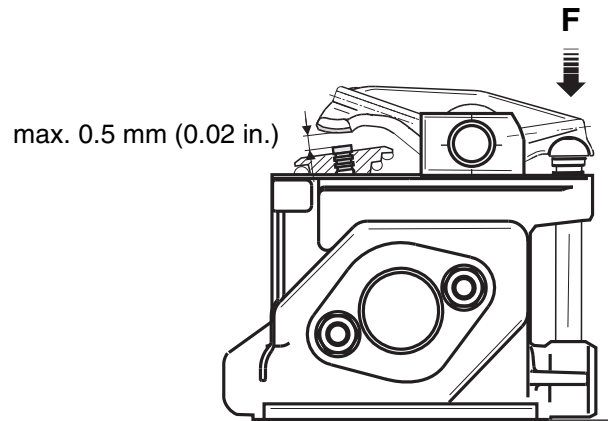

Fig. 3
Hydraulic valve tappet

05449,05451

8 valve spring support
9 radial direction

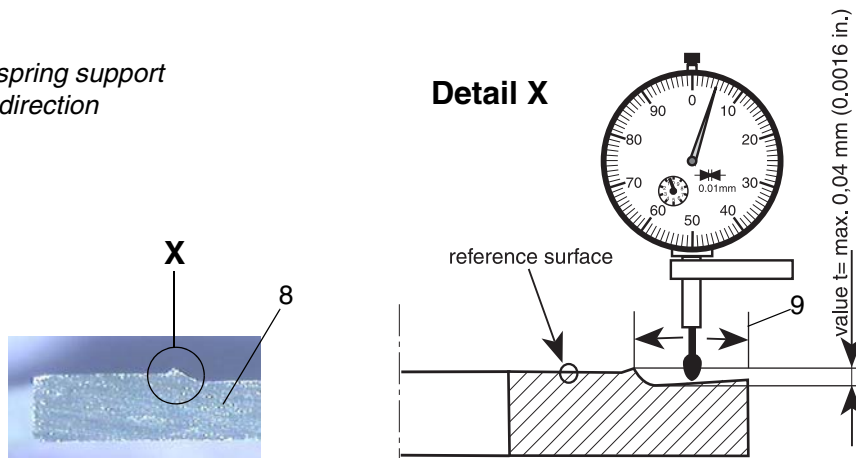

Fig. 4
Valve spring support

05449,05451

NOTE: The illustrations in this document show the typical construction. They may not represent full detail or the exact shape of the parts which have the same or similar function.

Exploded views are **not technical drawings** and are for reference only. For specific detail, refer to the current documents of the respective engine type.