

SERVICE INSTRUCTION

RUNNING MODIFICATIONS ON

ROTAX® ENGINE TYPE 912/914 (SERIES)

SI-912-020R10

SI-914-022R10

|| This SI revises SI-912-020R9 and SI-914-022R9 dated 30 December 2016.

Symbols used:

Please, pay attention to the following symbols throughout the Service Bulletin emphasizing particular information.

▲ **WARNING:** Identifies an instruction, which if not followed, may cause serious injury or even death.

■ **CAUTION:** Denotes an instruction which if not followed, may severely damage the engine or could lead to suspension of warranty.

◆ **NOTE:** Information useful for better handling.

|| | A revision bar outside of the page margin indicates a change to text or graphic.

1) Planning information

1.1) Engines affected

All versions of the ROTAX® engines type:

- 912 Series all - 912 pre-series engines all
- 914 Series all - 914 pre-series engines all

1.2) Concurrent ASB/SB/SI and SL

none

1.3) Reason

ROTAX® reserves the right to abandon or modify specifications, design, details, models or equipment at any time without obligation.

1.4) Subject

Running modifications on ROTAX® engine type 912/914 (Series).

1.5) Compliance

NONE - For Information Only

▲ **WARNING:** Non-compliance with these instructions could result in engine damage, personal injury or death!

1.6) Approval

The technical content of this document is approved under the authority of DOA Nr. EASA.21J.048.

1.7) References

In addition to this technical information refer to

- current issue of the Operators Manual (OM)
- engine data sheet
- power, torque and fuel consumption curves
- current issue of the Illustrated Parts Catalog (IPC)
- Installation Manual (IM)
- all relevant Alert Service Bulletins (ASB)
- all relevant Service Bulletins (SB)
- all relevant Service Instructions (SI)
- all relevant Service Letters (SL)
- Maintenance Manual (MM)
- Users Guide

- ◆ NOTE: The status of Manuals can be determined by checking the table of amendments of the Manual. The 1st column of this table is the revision status. Compare this number to that listed on the ROTAX WebSite: www.FLYROTAX.com. Updates and current revisions can be downloaded for free.

2) Material Information

2.1) Material - cost and availability

Price and availability will be provided on request by ROTAX[®] Authorized Distributors or their independent Service Centers.

2.2) Special tooling/lubricant-/adhesives-/sealing compound -

Price and availability will be supplied on request by ROTAX[®] Authorized Distributors or their independent Service Centers.

3) Accomplishment / Instructions

- ◆ NOTE: Before maintenance, review the entire documentation to make sure you have a complete understanding of the procedure and requirements to prevent mistakes from an incomplete review of all of the information in this document.

All the measures must be taken and confirmed by the following persons or facilities:

- ROTAX[®] -Authorized Distributors or their independent Service Center
- Persons with the respective Aviation Authority

▲ WARNING: Proceed with this work only in a non-smoking area and not close to sparks or open flames. Switch off ignition and secure engine against unintentional operation. Secure aircraft against unauthorized operation. Disconnect negative terminal of aircraft battery.

▲ WARNING: Risk of scalds and burns! Allow engine to cool sufficiently and use appropriate safety gear while performing work.

▲ WARNING: Should removal of a locking device (namely lock tabs, self-locking fasteners) be required when undergoing disassembly/assembly, always replace with a new one.

- ◆ NOTE: All work has to be performed in accordance with the relevant Maintenance Manual.

- ◆ NOTE: The illustrations in this document show the typical construction. They may not represent full detail or the exact shape of the parts which have the same or similar function.

|| Exploded views are **not technical** drawings and are for reference only. For specific detail, refer to the current documents of the respective engine type.

|| Translation into other languages might be performed in the course of language localization but does not lie within ROTAX[®] scope of responsibility. In any case the original text in English language and the metric units are authoritative.

4) Documentation

4.1) List of the valid pages

Chapter	Page	Date	Chapter	Page	Date	Chapter	Page	Date
00-00-00	1	04 17 2017		7	04 17 2017	78-00-00	1	05 28 2010
	2	04 17 2017		8	04 17 2017	79-00-00	2	04 15 2008
	3	04 17 2017		9	04 17 2017		1	12 30 2016
	4	04 17 2017		10	04 17 2017		2	12 30 2016
72-00-00	1	04 17 2017	74-00-00	1	04 17 2017			
	2	04 17 2017	75-00-00	2	04 17 2017			
	3	04 17 2017		1	04 15 2008			
	4	04 17 2017		2	04 15 2008			
73-00-00	1	04 17 2017		76-00-00	3	04 15 2008		
	2	04 17 2017	4		04 15 2008			
	3	04 17 2017	1		04 17 2017			
	4	04 17 2017	2		04 17 2017			
	5	04 17 2017	3		04 17 2017			
	6	04 17 2017	4		04 17 2017			

4.2) Table of amendments

Approval*
The technical content of this document is approved under the authority of DOA ref. EASA.21J.048.

Ser. No.	Section	Pages	Date of correction	Sign of acceptance	Date of accept. of resp. authority	Date of implementation	Sign/ Signature
0	00-00-00	all	04 15 2008	DOA*			
0	73-00-00	all	04 15 2008	DOA*			
0	75-00-00	all	04 15 2008	DOA*			
0	76-00-00	all	04 15 2008	DOA*			
0	78-00-00	all	04 15 2008	DOA*			
1	00-00-00	1,3	07 28 2008	DOA*			
1	73-00-00	5	07 28 2008	DOA*			
1	79-00-00	all	07 28 2008	DOA*			
2	00-00-00	1,3	11 03 2008	DOA*			
2	76-00-00	all	11 03 2008	DOA*			
2	79-00-00	1	11 03 2008	DOA*			
3	00-00-00	1,3	05 28 2010	DOA*			
3	74-00-00	all	05 28 2010	DOA*			
3	78-00-00	1	05 28 2010	DOA*			
4	00-00-00	1, 3	11 24 2010	DOA*			
4	74-00-00	4	11 24 2010	DOA*			
5	00-00-00	1, 2, 3	05 23 2011	DOA*			
5	73-00-00	6, 7, 8, 9, 10	05 23 2011	DOA*			
5	79-00-00	3,4	05 23 2011	DOA*			
6	00-00-00	1-4	09 03 2012	DOA*			
6	73-00-00	6-12	09 03 2012	DOA*			
6	79-00-00	1-6	09 03 2012	DOA*			
7	00-00-00	1,3	05 15 2013	DOA*			
7	72-00-00	1-4	05 15 2013	DOA*			
7	73-00-00	4,6-14	05 15 2013	DOA*			
7	74-00-00	4	05 15 2013	DOA*			
8	72-00-00	1-4	12 19 2014	DOA*			
8	79-00-00	1	12 19 2014	DOA*			
9	00-00-00	1-4	12 30 2016	DOA*			
9	72-00-00	1-4	12 30 2016	DOA*			
9	73-00-00	1-10	12 30 2016	DOA*			
9	79-00-00	1-2	12 30 2016	DOA*			
10	00-00-00	1-4	04 17 2017	DOA*			
10	72-00-00	1-4	04 17 2017	DOA*			
10	73-00-00	1-10	04 17 2017	DOA*			
10	74-00-00	1-2	04 17 2017	DOA*			
10	76-00-00	1-4	04 17 2017	DOA*			

◆ NOTE:

Replaces Service Instruction SI-912-020/SI-914-022R9, date of issue 30 December 2016. Revision includes deleted of the chapter 74-00-00 section "Introduction of a advanced start module (easy starting device for the electronic module)".

4.3) List of chapters

	00-00-00	Introduction
	72-00-00	Engine
	73-00-00	Fuel system
	74-00-00	Ignition system
	75-00-00	Cooling system
	76-00-00	Engine control
	78-00-00	Exhaust system
	79-00-00	Lubrication system

SECTION 72-00-00

1) Introduction of new cylinder heads part no. 413235/413245/413185/413195 for ROTAX® 912/14 Series

1.1) General Information

In the course of continuous development and standardization with ROTAX® 912 i Series, a new cylinder head with modifications in its mold has been introduced. Due to these changes the coolant temperature instead of the cylinder head temperature in the aluminium will be displayed. Check the temperature limit for the new positioned measuring point of the cylinder head displayed in the cockpit and if necessary correct its naming (measuring position) and limit.

■ **Caution:** The cooling capacity is not affected by the change of cylinder heads (new configuration).

The new cylinder heads has been already installed on the following engines:

- 912 A from S/N 4 410 982 inclusive
- 912 F from S/N 4 413 020 inclusive
- 912 S from S/N 4 924 544 inclusive
- 912 UL from S/N 6 770 937 inclusive
- 912 ULS from S/N 6 781 410 inclusive
- 914 F from S/N 4 421 178 inclusive
- 914 UL from S/N 7 682 718 inclusive

◆ **NOTE:** Identifying new cylinder heads: The electrical connection of the temperature sensor is pointing upwards. New configuration see fig. 2. Old configuration see fig. 3.

Part no. of new cylinder heads:

Engine type		
912 A/F; 914 F	912 S	cylinder head position
part no. 413235 part no. 413236	part no. 413185	2/3
part no. 413245 part no. 413246	part no. 413195	1/4
912 UL; 914 UL	912 ULS	cylinder head position
part no. 413235 part no. 413236	part no. 413185	2/3
part no. 413245 part no. 413246	part no. 413195	1/4

◆ **NOTE:** It is NOT mandatory to retrofit engines with the old cylinder heads. The different versions of the cylinder heads can be mixed installed, but make sure, if and at which position the cylinder head temperature and coolant temperature is measured. This also defines the naming of the indicating instrument with the appropriate temperature limit.

In case of a retrofitting/repair or overhaul, observe the installation and maintenance related changes.

Proof of certification to the latest requirements such as FAR or EASA has to be supplied by the aircraft manufacturer.

1.2) Installation relevant changes

See latest Installation Manual for the related engine type.

1.2.1) Coolant temperature limit (measured at cylinder head measuring point)

Coolant temperature limit for measuring point in the cylinder head (new configuration)	Engine type
maximum 120 °C (248 °F)	912 Series
maximum 120 °C (248 °F)	914 Series
Permanent monitoring of coolant temperature is necessary.	

1.2.2) Temperature sensor

Regarding change of position of the temperature sensor, see fig. 2 and fig. 3.

◆ NOTE: The temperature sensor part no. 965531 and its connection is not changed.

In case of a retrofitting/repair or overhaul, observe the installation and maintenance related changes. If a cylinder head of the new version is installed at the position of the temperature measurement, the sensor wiring may need to be changed due the new sensor position.

1.2.3) Indicating instrument

The following steps are necessary for checking the relevant indicating instrument of the cockpit:

Step	Procedure
1	Check the engine serial number S/N, if the aircraft is affected by this SI.
2	Check of maintenance documentation if a repair or maintenance was performed on one of the cylinder heads.
3	Check the part numbers of the cylinder heads. See fig.1.
4	Check of the cockpit (indicating instruments) or the aircraft-specific manuals or consultation with the aircraft manufacturer or its service facilities if the coolant temperature or cylinder head temperature is displayed.
5	The measurement position naming in the indicating instrument or the operating limit must be amended or corrected in consultation with the aircraft manufacturer, if necessary. See chapter 1.2.1).

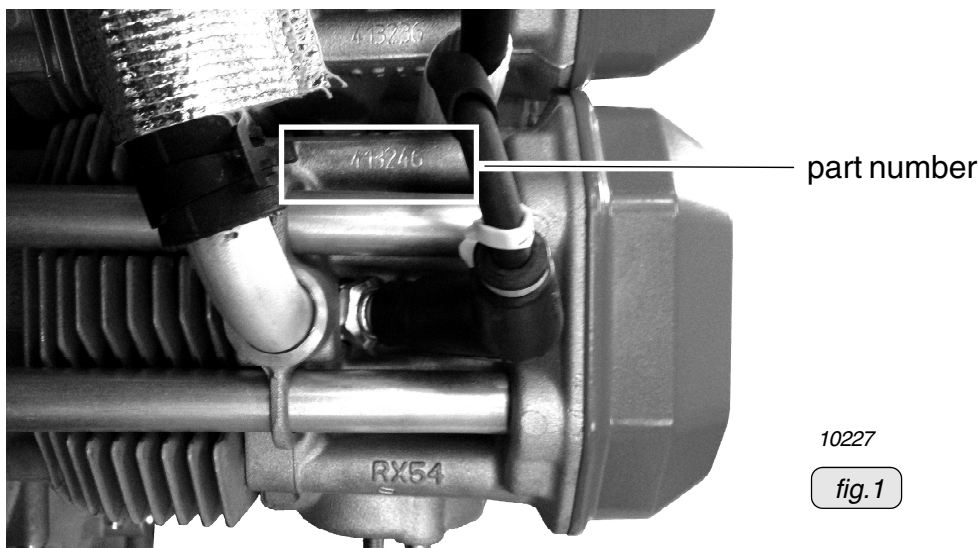

1.3) Changes concerning maintenance (cylinder head 2/3 assy.)

(see fig. 2 and fig. 3)

See latest Maintenance Manual (Heavy).

◆ NOTE: Contrary to the current design, the temperature sensor is directly flooded with coolant. Therefore the thread must be sealed with LOCTITE.

The following changes concerning maintenance must be observed:

1. Clean the thread of the temperature sensor.
2. Apply LOCTITE 243 to the thread of the temperature sensor. Tightening torque 10 Nm (90 in.lb).
3. Plug the respective wiring harness connector into the temperature sensor.
4. Engine assembly.
5. Fill with operating fluids (coolant, oil or fuel). See also chapter 12-20-00 current issue of Maintenance Manual Line for the engine type 912/914 Series.
6. Conduct test run. See also chapter 12-20-00 current issue of Maintenance Manual Line for the engine type 912/914 Series.

1.4) Concurrent ASB/SB/SI and SL

Service Bulletin - SB-912-066/SB-914-047, title "Change of measurement method from cylinder head temperature to coolant temperature", current issue.

1.5) Illustration

The following drawings should convey additional information:

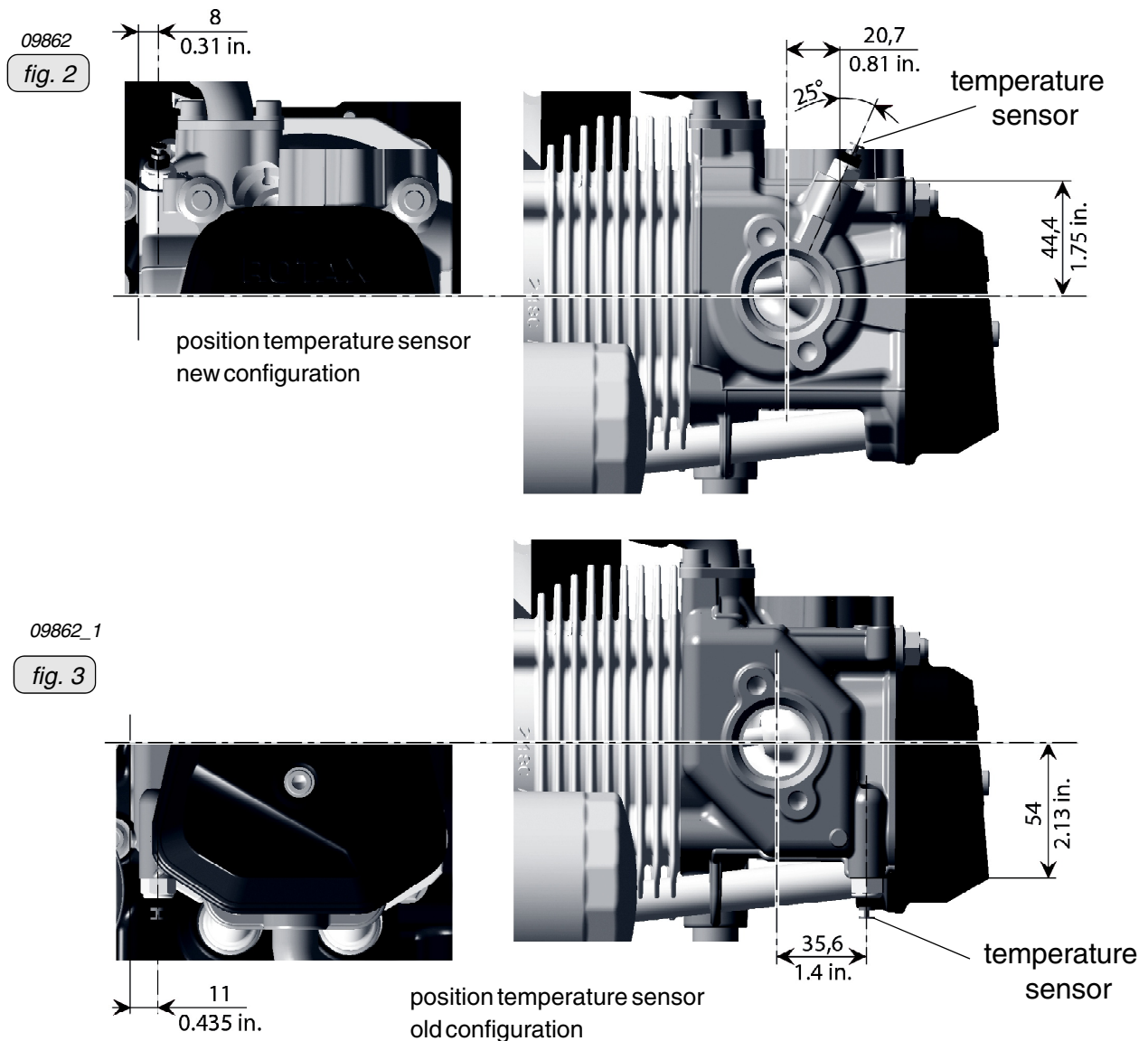

2) Change of the tightening torque procedure for the installation of the cylinder heads

In addition to the information in the Maintenance Manual (Heavy), the procedure regarding changes of the tightening torque for the installation of cylinder heads is also specified in a Service Instruction.

See therefore Service Instruction SI-912-025/SI-914-026 „Change of the tightening torque procedure for installation of the cylinder heads”, latest issue.

SECTION 73-00-00

1) Introduction of a new flexible fuel line assy. part no. 874911 for ROTAX® 912 Series

1.1) General Information

(see fig. 1 and fig. 2)

In the course of continuous development and for better assembly and maintenance a new flexible fuel line (part no. 874911) has been introduced.

Installation of this new fuel line requires the following modifications:

- mechanical machining at the intake manifold for the attachment of the cable clamp. At engine repair/general overhaul be aware that the fixation of the flexible fuel line needs an appropriate contact surface. If necessary replace the intake manifold or machine the contact surface according to the following instruction.

The new fuel line has been already installed on the following engines:

- 912 A from S/N 4 410 713 up to S/N 4 410 727 inclusive
- 912 F from S/N 4 412 923 up to S/N 4 412 925 inclusive
- 912 S from S/N 4 923 384 up to S/N 4 923 458 inclusive
- 912 UL *) from S/N 4 408 199 up to S/N 4 408 331 inclusive
- 912 ULS*) from S/N 5 647 489 up to S/N 5 648 135 inclusive
- 912 ULSFR*) from S/N 4 430 445 up to S/N 6 374 048 inclusive

*) optional installation possible

parts requirement:

Fig item no	New part no	Qty per engine	Description	Old part no	application
1	874911	1	fuel line assy.	874294	912
2	940872	2	banjo bolt M8x1x24	-	flexible fuel line
3	847795	2	spacer 8.4/12/7.5	-	flexible fuel line
4	950141	6	sealing ring A8x13	-	banjo bolt
5	651430	2	cable clamp 12/M8	-	flexible fuel line
6	940481	2	hex. screw M8X30	240276	carburetor socket
8	942671	2	hex. nut M8	-	cable clamp
9	866719	2	tie wrap 550x8.0	-	flexible fuel line
10	950143	3	gasket ring 8.2/13/1.4	-	banjo bolt/ clamp block

◆ NOTE: It is not mandatory to retrofit engines with the old stainless steel fuel line!

For a retrofit to a flexible fuel line system the following new parts are required:

parts requirement:

Fig item no	New part no	Qty per engine	Description	Old part no	application
	881980	1	flex. fuel line retrofit kit		retrofitting flexible fuel line
consisting of:					
	874911	1	fuel line assy.	874294	912
	940872	2	banjo bolt M8x1x24	-	flexible fuel line
	847795	2	spacer 8.4/12/7.5	-	flexible fuel line
	950141	6	sealing ring A 8x13	-	banjo bolt
	651430	2	cable clamp 12/M8	-	flexible fuel line
	940481	2	hex. screw M8X30	240276	carburetor socket
	942671	2	hex. nut M8	-	cable clamp
	866719	2	tie wrap 550x8.0	-	flexible fuel line
	950143	5	gasket ring 8.2/13/1.4	-	banjo bolt/ clamp block
	851325	1	clamp block - 912	-	clamp block
	230150	1	gasket ring 10x14	-	clamp block
	641733	1	plug screw M10x1x8	-	clamp block
	840518	1	hex. screw M5x18	-	clamp block
	941785	1	banjo bolt assy.	-	clamp block

d06375

APRIL 17TH, 2017

Copyright - BRP-Rotax GmbH & CO KG. All rights reserved.

SI-912-020R10

SI-914-022R10

73-00-00

page 1 of 10

956312	1	ring hose nipple	-	return line
250311	2	washer 8.4	-	carburetor socket

- Install the flexible fuel line (1) with the double ring hose nipple (13) and sealing ring (10) on the clamp block (11). Tightening torque of banjo screw (14) 10 Nm (90 in. lb.) (see fig. 1).
- Install the ring hose nipple (15) with distance sleeve (3) and sealing ring (4) on the carburetors. Tightening torque of banjo screw (2) 10 Nm (90 in. lb.)

◆ **NOTE:** In case of a retrofit on configurations with steel fuel lines remove the screw connectors (12) and remove remaining sealant residues, taking care that they do not get into the carburetor or the fuel system.

- For installation on an old style intake manifold perform the following: Remove the intake manifold and machine the nut/clamp contact area until the surface is parallel with the sealing surface of the carb socket. The thickness of the material must not be dressed down less than 10,5 mm (0.413 in.) and should be smooth and flat so that the nut/clamp assembly has an even contact surface (see fig. 2).

- Ensure proper support of the flexible fuel line. Install Hex. screw (6) and washer (7) with 15 Nm (133 in. lb.). Install the cable clamp (5) at the hex. screw (6) of the carburetor socket with the hex. nut (8). Tightening torque of hex. nut (8) 24 Nm (213 in. lb.)

■ **CAUTION:** While tightening hex. nut (8), hold hex. screw (6) with a wrench to prevent it from loosening. Always fix the flexible fuel line at the compensation tube with clamps (9) in such a way that no chafing is possible.

1.2) Illustration

the following drawings should convey additional information:

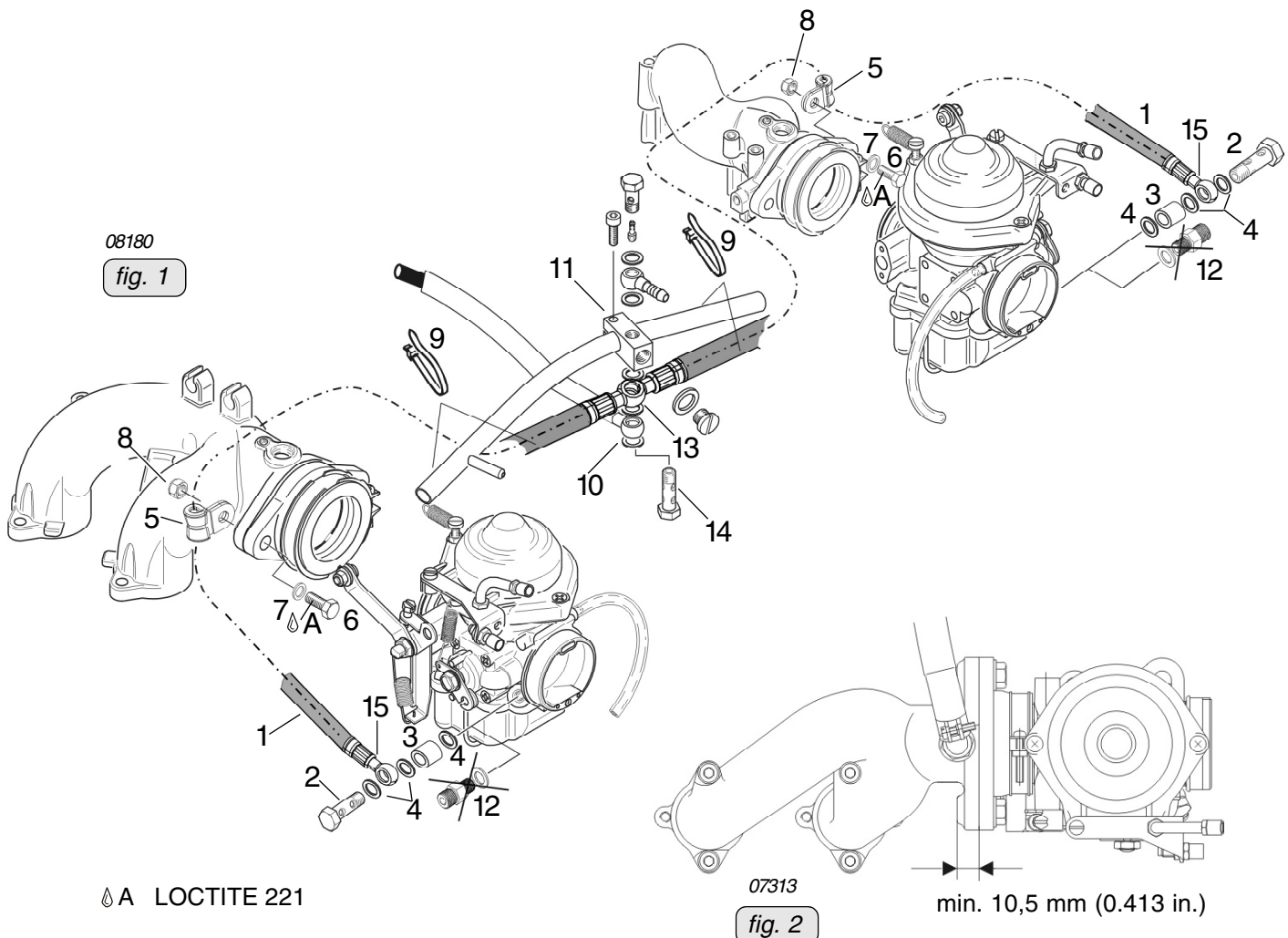

2) Introduction of a new gasket part no. 950226 for fuel pump ROTAX® 912 Series

2.1) General Information

(see fig.1)

In the course of continuous development a new gasket (1) (part no. 950226) has been introduced.

The new gasket has been already installed on the following engines:

- 912 A from S/N 4 410 744 inclusive
- 912 F from S/N 4 412 929 inclusive
- 912 S from S/N 4 923 486 inclusive
- 912 UL from S/N 4 408 421 inclusive
- 912 ULS from S/N 5 648 605 inclusive
- 912 ULSFR from S/N 6 374 096 inclusive

The new gasket has been already included in all fuel pumps delivered as spare part:

- fuel pump as of S/N 07.002119

parts requirement:

Fig item no	New part no	Qty per engine	Description	Old part no	application
1	950226	1	gasket	950225	fuel pump

The gasket is interchangeable.

2.2) Illustration

the following drawings should convey additional information:

- ◆ NOTE: On the sealing surfaces of the gearbox housing and the fuel pump no sealing compound has to be used.

⚠ B LOCTITE 243

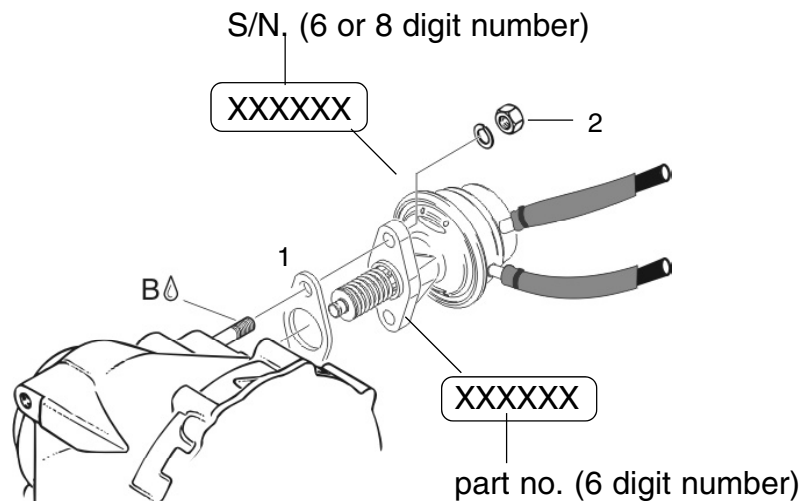

08353
fig. 1

3) Introduction of a new compensation tube part no. 924541 for ROTAX® 912/914 Serie

3.1) General Information

(see fig. 1 and 2)

In the course of continuous development a new compensation tube (1) (part no. 924541) has been introduced which need not be removed during carb synchronization, making the process easier to perform.

In this connection the following modifications became necessary:

- position of connection fitting (3) on compensation tube remains approximately constant
- additional screw (2) part no. 940980 for connection fitting (3)
- new tube (4) part no. 956143 (5) part no. 956141

The new compensation tube has been already installed on the following engines:

- 912 A from S/N 4 410 807 inclusive
- 912 F from S/N 4 412 949 inclusive
- 912 S from S/N 4 923 676 inclusive
- 912 UL from S/N 4 409 113 inclusive
- 912 ULS from S/N 5 650 899 inclusive
- 914 F from S/N 4 420 807 inclusive
- 914 UL from S/N 6 772 763 inclusive

parts requirement:

Fig item no.	New part no.	Qty per engine	Description	Old part no.	application
	924541	1	compensation tube assy.	924540	intake manifold
	*)	1	tube 81 mm (3.2 in.)	-	compensation tube
		1	tube 66 mm (2.6 in.)	-	compensation tube

*) in a roll tube part no. 956140

◆ **NOTE:** Regarding interchangeability: It is not possible to exchange individual parts. The new compensation tube are only **together** interchangeable with the tube part no. 956141. In case of spare parts the relevant configurations must be observed.

Special tools:

Item no.	New part no.	Qty.	Description	Old part no.	Application
		1	hose clamping pliers ¹⁾		tube
		1	hose nipple	940557	intake manifold
		1	sealing ring 6.2/8.9/1	830890	intake manifold

¹⁾ e.g. HAZET® **mean size** or equivalent. See fig. 2.

Pneumatic synchronization:

(see fig. 2)

Adjustment of the two carburetors to equal flow rate (mechanical or pneumatical synchronisation) has to be performed in accordance with the relevant Maintenance Manual ROTAX® 912/914 and following changes must be observed:

additional variant (taking advantage of the new compensation tube):

1. Install the vacuum gauge.
2. Clamp the tube with hose clamping pliers (6). Observe the position! The tube (1) must not removed.
3. Unscrew the screw (7).
4. Install the hose nipple M6 (8) with the sealing ring (9).
5. After synchronization tightened the screw M6x6 (7) with LOCTITE 221.

Monitoring of the intake manifold pressure:

The monitoring of the intake manifold pressure has to be performed in accordance with the relevant Installation Manual ROTAX® 912/914 and following changes must be observed:

1. Unscrew the screw (2) from the connecting fitting (3) for indicating instrument.

◆ **NOTE:** If it is not possible to stabilize the intake manifold pressure, tighten the screw M3.5x6 (2) with LOCTITE 221. Install color markings on the screw.

3.2) Illustration

the following drawings should convey additional information:

compensation tube **part no. 924540**

08371
fig. 1

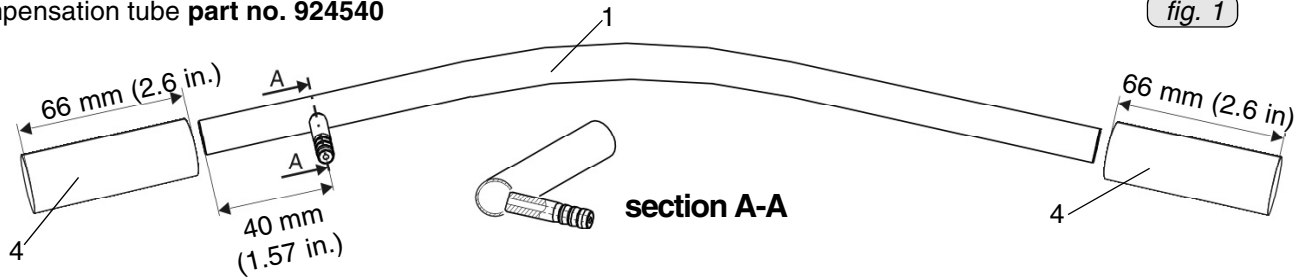

compensation tube **part no. 924541**

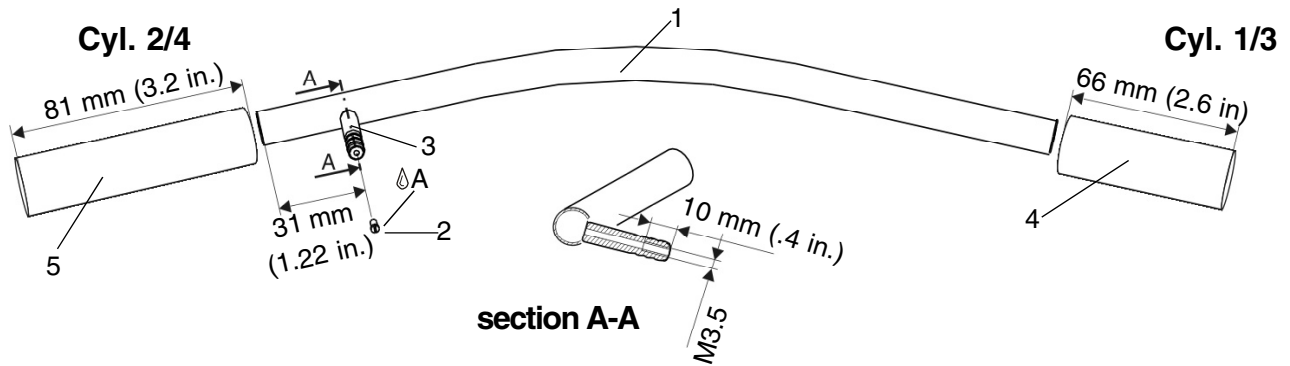

- 1 compensation tube
- 2 screw M3.5x6
- 3 connection fitting
- 4, 5 tube
- 6 hose clamp pliers
- 7 hex. screw M6x6
- 8 hose nipple M6
- 9 sealing ring 6.2/8.9/1

LOCTITE 221

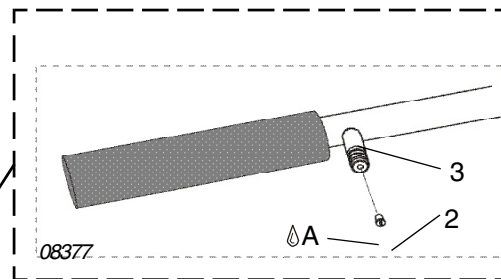

08449
fig. 2

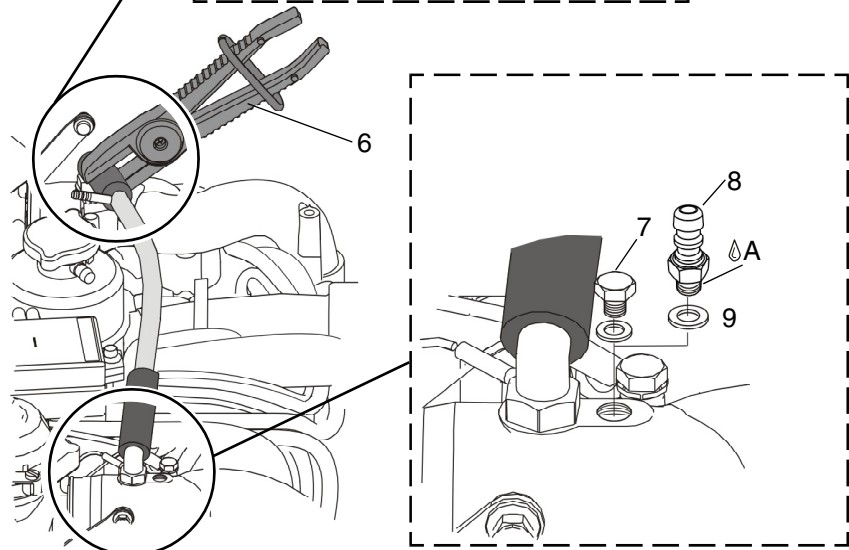

4. Introduction of a new fuel pump assy. part no. 893115 for ROTAX® 912 Series

4.1) General Information

(see fig. 1 to fig. 7)

In the course of continuous development a new fuel pump assy. (part no. 893110 and/or part no. 893114) has been introduced.

The new fuel pump assy. part no. 893110 and part no. 893114 has been already installed on the following engines:

- 912 A from of S/N 4 410 906
- 912 F from of S/N 4 412 990
- 912 S from of S/N 4 924 185
- 912 UL from of S/N 6 770 279
- 912 ULS from of S/N 6 778 296

In the course of standardization a new "basic" fuel pump assy. (part no. 893115) has been introduced, which can be configured with the appropriate nipples or fuel hoses.

The new fuel pump assy. part no. 893115 has already been installed on the following engines:

- 912 A from of S/N 4 410 977 inclusive
- 912 F from of S/N 4 413 018 inclusive
- 912 S from of S/N 4 924 497 inclusive
- 912 UL from of S/N 6 770 893 inclusive
- 912 ULS from of S/N 6 781 191 inclusive

parts requirement:

Fig item no	New part no	Qty per engine	Description	Old part no	application
-	893115	1	fuel pump assy.	892546	912 with isolating flange (gasket) and O-ring
-	950228	1	isolating flange (gasket)	-	fuel pump assy.
-	631870	1	O-ring	-	fuel pump assy.
-	874337	1	fuel hose assy.	-	fuel pump assy. (fuel outlet)
-	874347	1	fuel hose assy.	-	fuel pump assy. (fuel inlet)
-	250425	2	gasket ring 10.2/15/1.5	-	fuel pump assy.
-	840740	1	nipple 7/3.8	-	fuel pump assy. (fuel outlet)
-	840745	1	nipple 9/5.7	-	fuel pump assy. (fuel inlet)
-	840770	1	adapter AN-5 (9/16 UNF)/M10x1	-	fuel pump assy. (fuel inlet)
-	840775	1	adapter AN-6 (1/2 UNF)/M10x1	-	fuel pump assy. (fuel outlet)
-	942674	2	hex. nut M8	-	fuel pump assy.
-	-	2	lock washer A8	945752	fuel pump assy.

- ◆ NOTE: In case of an upgrade the parts listed above have to be used, the fuel pump must be installed using the new isolating flange (gasket). Amendments concerning service or installation need to be adhered to. Proof of certification to the latest requirements such as FAR or EASA has to be supplied by the aircraft manufacturer.

Fuel pump part no. 893110 include following parts:		
Part no.	Qty	Description
893115	1	fuel pump assy.
950228	1	isolating flange
631870	1	O-ring
840740	1	nippel 7/3.8 (pump outlet)
840745	1	nippel 9/5.7 (pump inlet)
250425	2	gasket ring 10.2/15/1.5

Fuel pump part no. 893114 include following parts:		
Part no.	Qty.	Description
893115	1	fuel pump assy.
950228	1	isolating flange
631870	1	O-ring
874337	1	fuel hose
874347	1	fuel hose
250425	2	gasket ring 10.2/15/1.5
840770	1	adapter AN-5 (9/18 UNF)/M10x1 (pressure hose)
840775	1	adapter AN-6 (1/2-20 UNF)/M10x1 (suction hose)

◆ NOTE: Through this configurability the two fuel pumps (part no. 893110 and part no. 893114) are no longer available and can be composed of the following parts.

4.2) Retrofit of fuel pump assy. part no. 893110 to part no. 893115

See current issue of Maintenance Manual Heavy.

4.3) Retrofit of fuel pump assy. part no. 893114 to part no. 893115

See current issue of Maintenance Manual Heavy.

4.4) Appendix

the following drawings should convey additional information

fuel pump assy. part no. 893110

Dimensions without tolerance ± 0.3 mm (0.012 in.)

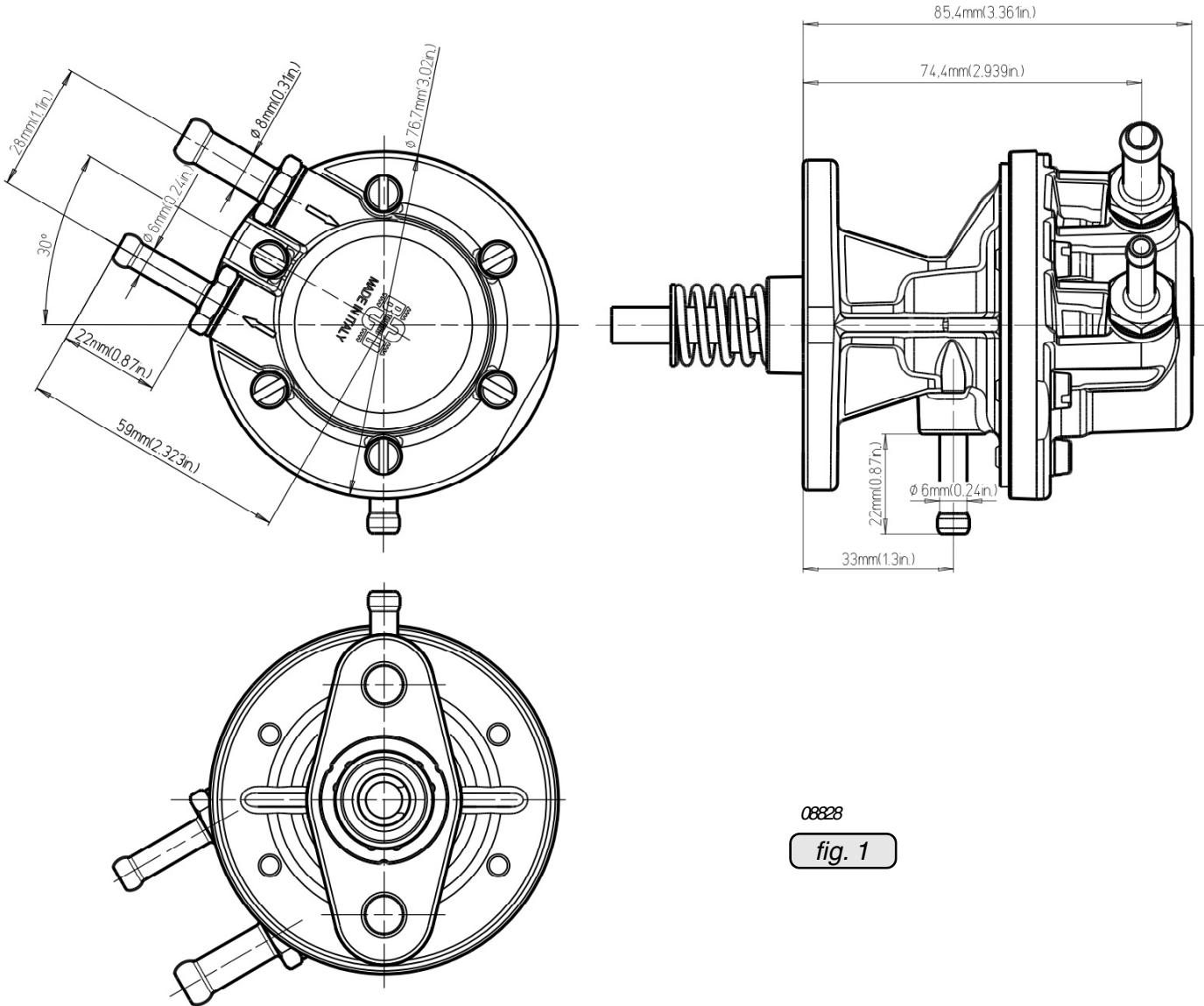

08828

fig. 1

Dimensions without tolerance ± 0.012 in.

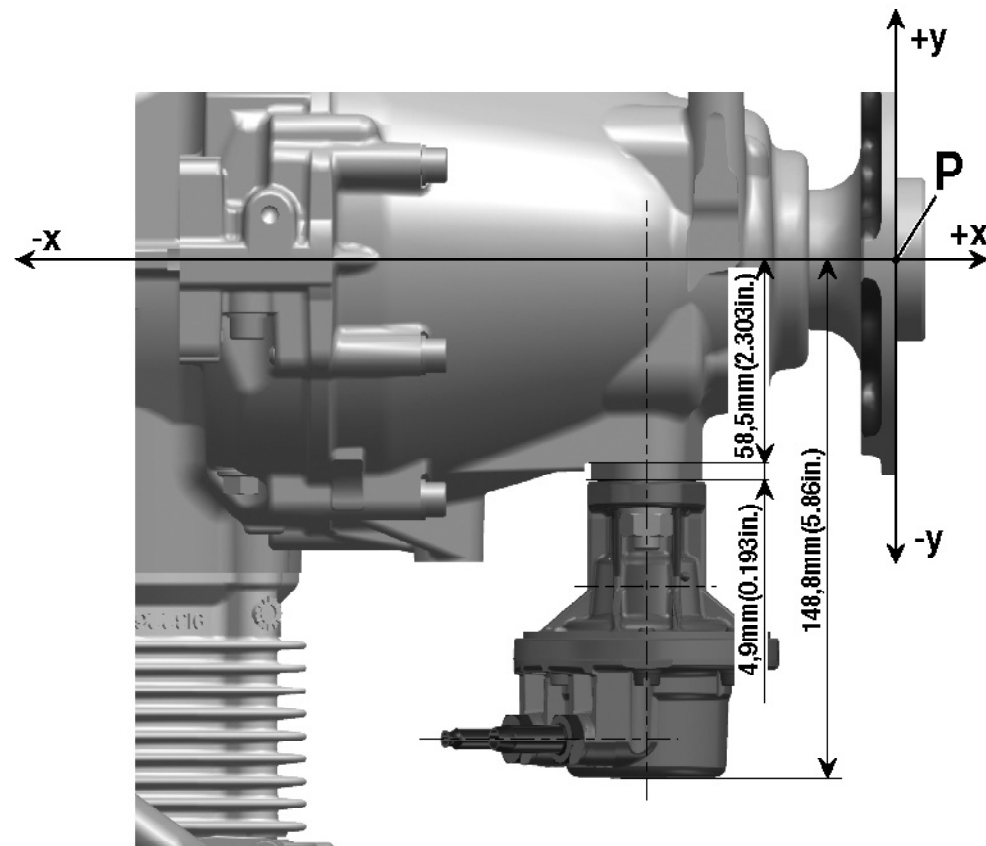
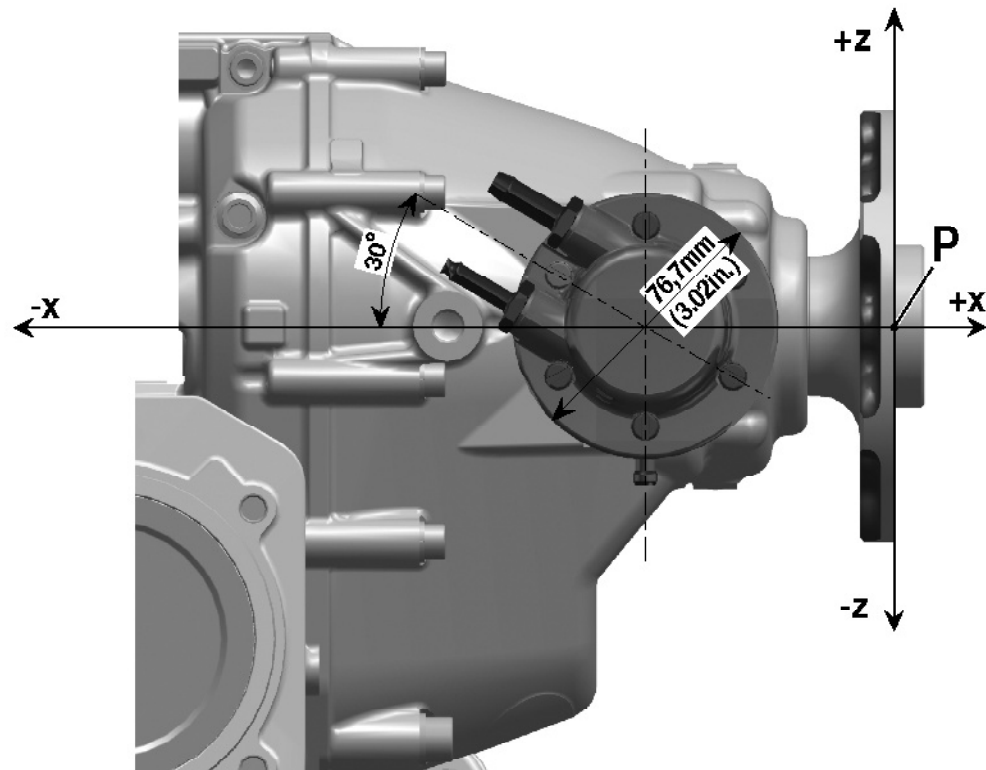

08828

fig. 2

NOTES

SECTION 74-00-00

1.) Introduction of a advanced start module (easy starting device for the electronic module)

In addition to the information in the Maintenance Manual (Heavy), the information regarding Advanced Start System for ROTAX ® Aircraft Engines is also specified in a Service Instruction.

See therefore Service Instruction SI-912-028 „Advanced Start System for ROTAX ® Aircraft Engines Type 912 S / 912 ULS / 912 ULSFR (Series)”, latest issue.

NOTES

SECTION 75-00-00

1.) Introduction of a new expansion tank assy.

1.1) General Information

(see fig 1, 2 and 3)

In the course of further development and standardization the position of the expansion tank (1) has been optimized!

In this connection the following modifications became necessary:

- position of connection (2) to overflow bottle (from 0° to 30±3°)
- position of connection (3) to radiator (from 51° to 27±3°)
- angle of inlet socket (4) from cylinder 4 (34° inclined)
- length of inlet socket (5) from cylinder 3 (length increased by 13,4±3 mm)
- length of coolant hose (6) from cylinder 1 (length increased from 270 mm to 285 mm)
- length of coolant hose (7) from cylinder 4 (shortened from 100 mm to 85 mm)
- new spring type hose clamps (8) to attach the coolant hoses (expansion tank and water pump)

The new expansion tank and the new type of hose clamps have been already installed on the following engines:

- 912 A as of S/N 4,410.419
- 912 F as of S/N 4,412.808
- 912 S as of S/N 4,922.606
- 912 UL as of S/N 4,404.020
- 912 ULS as of S/N 4,426.395
- 912 ULSFR as of S/N 4,429.589
- 914 F as of S/N 4,420.235
- 914 UL as of S/N 4,417.949

List of part no.:

Item no.	New part no.	Qty.	Description	Old part no.	Application
1	922665	1	expansion tank assy.	922398	cooling system
8	851640	16	spring type clamp	251875	cooling system
6)	1	coolant hose 285 mm	922542	cylinder 1
7)	1	coolant hose 85 mm	922541	cylinder 4

) water hose in meters part no. 922250.

◆ NOTE: Engines equipped with the old expansion tank, old hose clamps and coolant hoses of old length do not have to be retro fitted with the new equipment!

At engine repair/general overhaul be aware that because of the small distance of the tubes (between cylinder 1 and 3) the spring type hose clamps can not be fitted on the expansion tank part no. 922398.

Due to the different inlet and outlet positions on the expansion tanks, hoses of different length are required. Always verify correct hose length and slip-on length.

Special tools:

Item no.	New part no.	Qty.	Description	Old part no.	Application
	877840	1	spring clamp pliers ⁾		spring type clamp

) e.g. HAZET®, BERNER® or equivalent. See fig. 3.

Assembly:

- Inspect the rubber plate (10).

◆ NOTE: Wear of up to 1 mm from original thickness can be tolerated!

d02674

- Install the coolant hose (6) 285 mm to cylinder 1 and the new coolant hose (7) 85 mm to cylinder 4. For attaching all the coolant hoses from expansion tank, water pump, cylinders, use the new spring type clamps.

■ **CAUTION:** Take care of appropriate slip-on length of the coolant hoses on the corresponding connection socket. Verify tight fit of clamps and hoses and check for leakage. Always fit the clamps such that they can not wear on any component and use a suitable tool (see fig. 3) for fitting them.

1.2) Illustration

the following drawings should convey additional information:

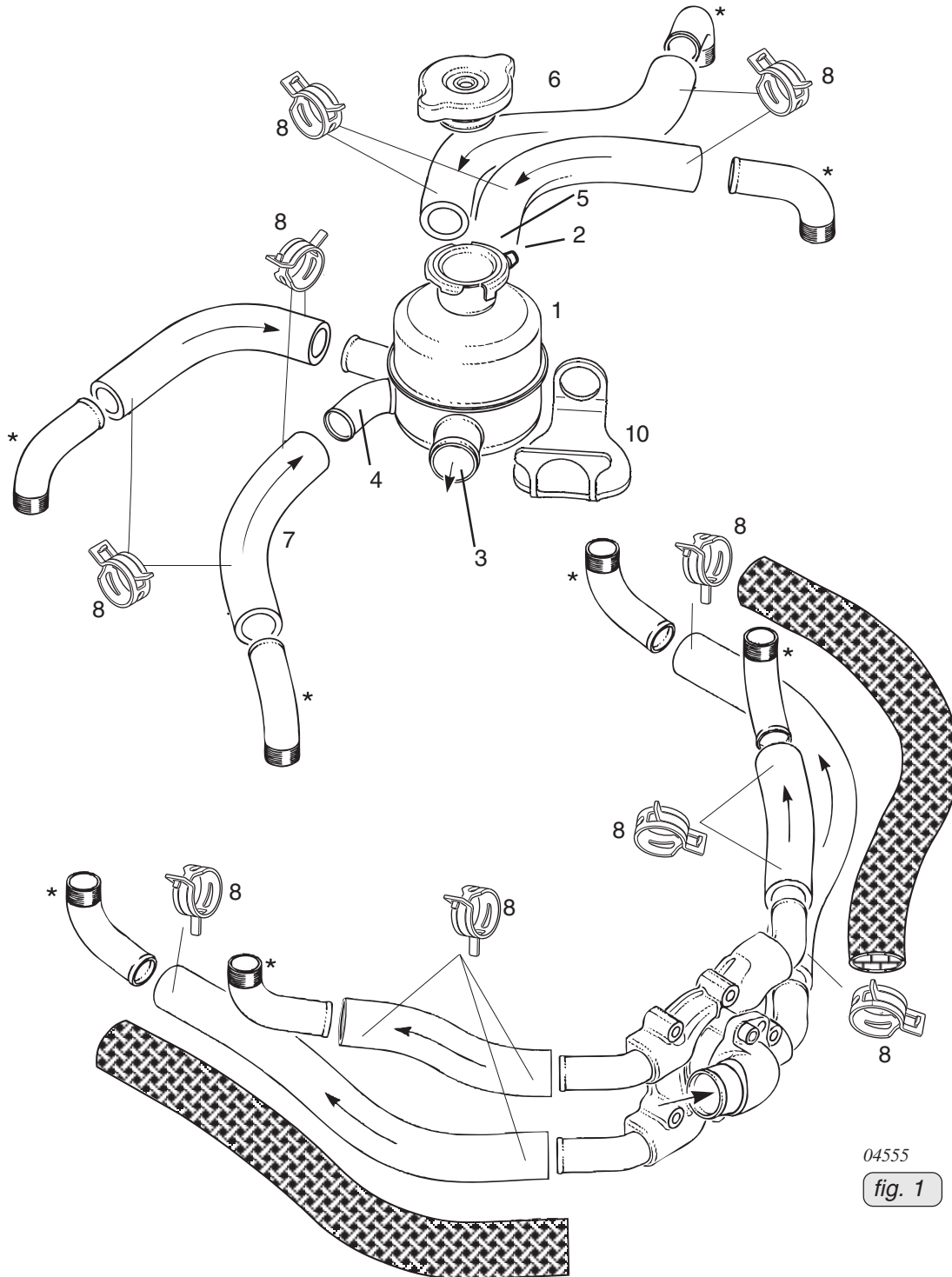

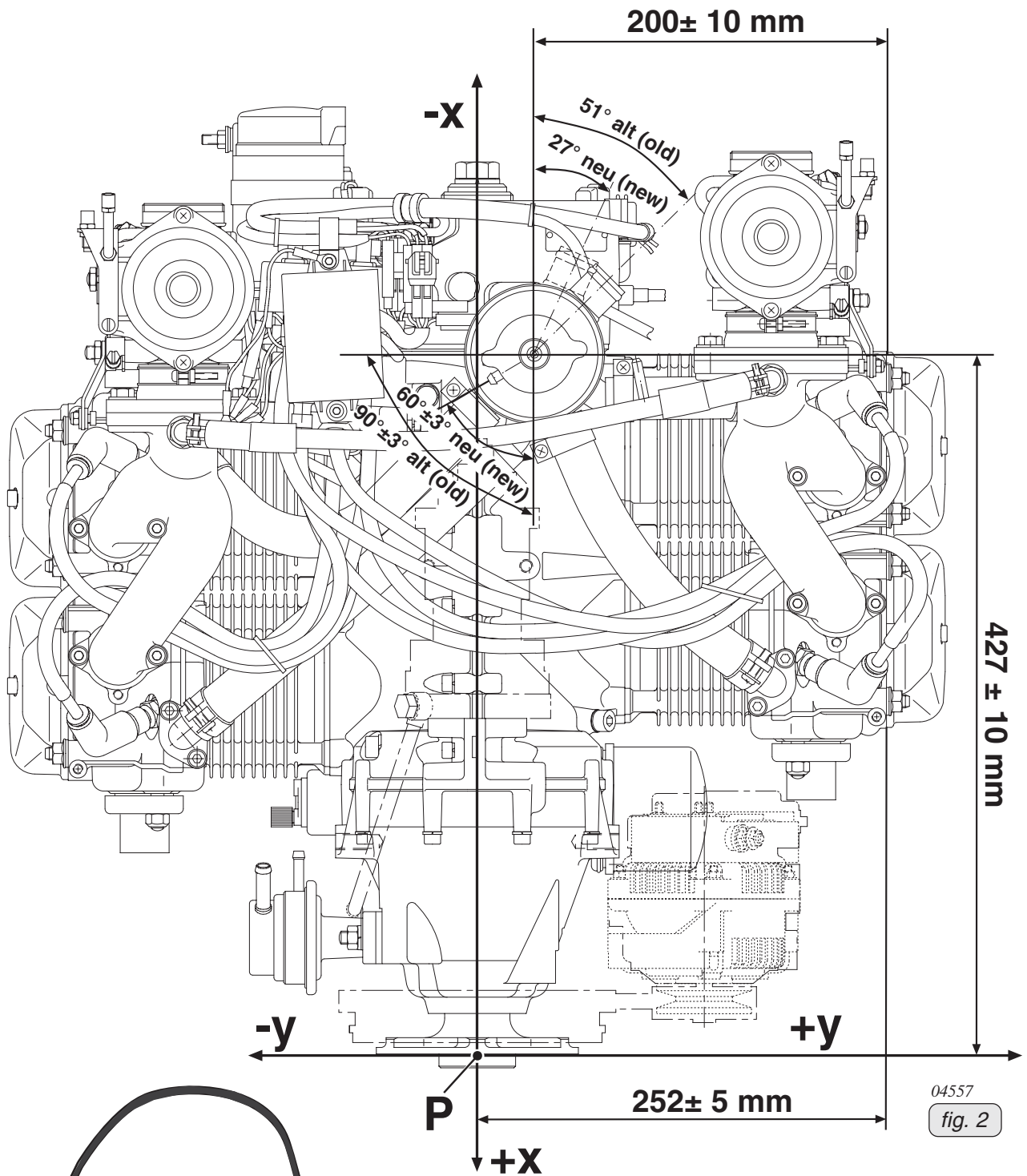

04557

fig. 2

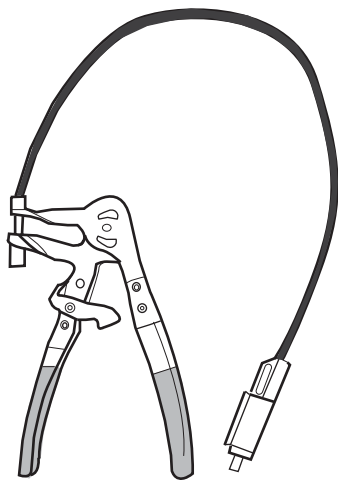

08380

fig. 3

NOTES

SECTION 76-00-00

1.) Introduction of a new 3-way solenoid valve part no. 874313 for ROTAX® 914 Series

1.1) General Information

Owing to a change of supplier for the new 3-way solenoid valve (part no. 874313) an adapted wiring harness and an airbox part no. 667574 have been introduced.

The new 3-way solenoid valve has been already installed on the following engines:

- 914 F as of S/N 4,420.710
- 914 UL as of S/N 4,419.744

1.1.1) Interchangeability of parts

The current 3-way solenoid valve part no. 874310 has limited availability.

Particularly for repair, and exchange purposes the retrofit kit part no. 881040 is provided.

◆ NOTE: If replacement of wiring harness part no. 966490 is necessary the 3-way solenoid valve must be also replaced.

Accessories and attachment of the 3-way solenoid valve could differ because of the possible variants of the airbox.

1.1.2) Disassembly and assembly

See the latest Maintenance Manual 914.

2.) Introduction of a new pressure sensor part no. 274051 for ROTAX® 914 Series

2.1) General Information

Due to the termination of production of the ambient pressure sensor (part no. 966507) a new ambient pressure sensor part no. 274051 has been introduced. The new ambient pressure sensor is of different size and also has a different connector. The connection for the wiring harness had to be changed.

Pressure sensor and wiring harness have already been installed on the following engines:

- 914 F as of S/N 4,420.863
- 914 UL as of S/N 6,773.116

2.1.1) Interchangeability of parts

The current pressure sensor part no. 966507 is of limited availability.

Fig No.	New p/n	Qty/ engine	Description	Old part no.	Application
1	274051	1	pressure sensor	966507	ambient pressure
3	666012	1	adapter cable	-	wiring harness
4	924990	1	bracket	-	pressure sensor

◆ NOTE: If replacement of wiring harness part no. 966493 is necessary the pressure sensor and the bracket must be also replaced.

2.1.2) Disassembly and/ or new assembly

See Fig. 1 and 2.

1. Disconnect the pressure sensor (2) from the wiring harness.
2. Connect adapter cable (3) to wiring harness and to the new pressure sensor (1).
3. Install bracket (4) onto pressure sensor.

■ CAUTION: Route all wiring so that there will be no sharp bends or chafing.

4. Position adapter cable and secure with cable binders (5).

2.2) Summary

The instructions have to be conducted accordingly.

2.3) Illustration

the following drawings should convey additional information:

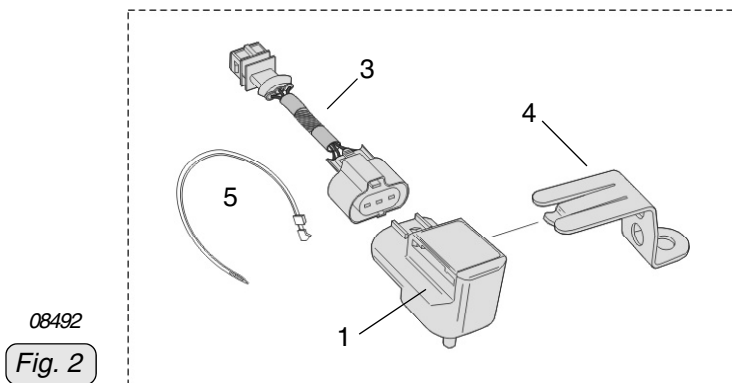
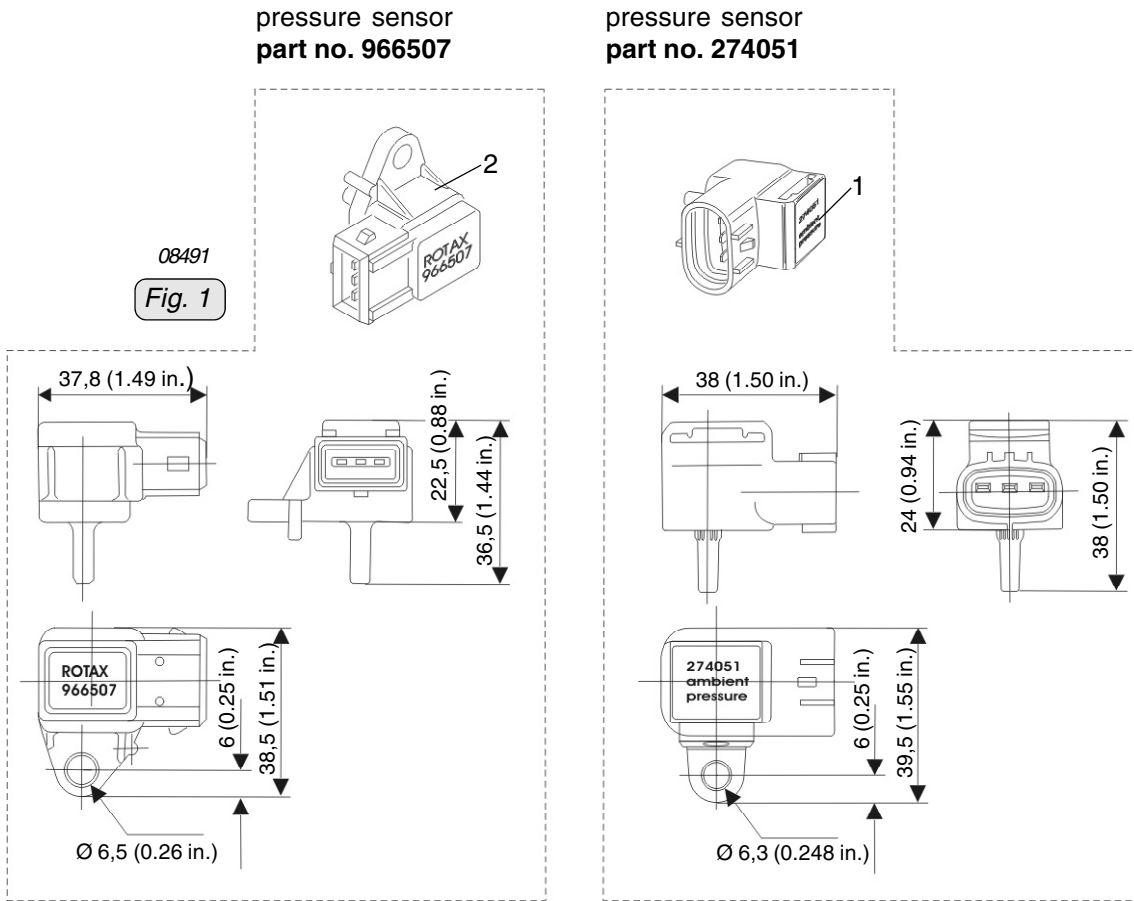

3.) Introduction of a new FLYdat part no. 886858 for ROTAX® 912/914 Series

3.1) General Information

In the course of continuous development a new FLYdat part no. 886858 has been introduced, which simplifies data selections, because the new FLYdat operates via USB (own power supply).

3.1.1) Interchangeability of parts

At replacement take care of the following:

Take care of the respective oil pressure sensor! See also 79-00-00 sec. 1.3).

- ◆ NOTES: For more information, please contact an authorized distributor or Service Center for ROTAX® aircraft engines.

part no. overview:

The following tables offer additional information about characteristics of the different versions.

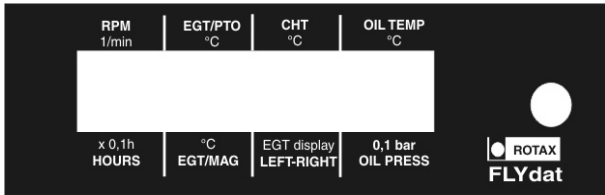
Model 1993	FLYdat part no. 886855 German, 886856 English
Characteristics	<ul style="list-style-type: none"> - 2 different front panels (German and English) - Service messages can only be reset by a ROTAX® authorized distributor - External warning lamp - Jack plug
Software	<ul style="list-style-type: none"> - Read out of data via RDAT part no. 886980 (no direct software for the PC) or - FLYdat monitoring device part no. 891315 (Windows system software)
	

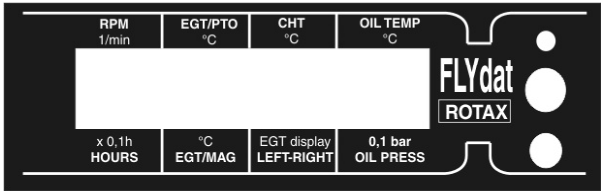
Model 2004	FLYdat part no. 886857
Characteristics	<ul style="list-style-type: none"> - 1 version (English) - consistent design of the front panel - Button to reset the service messages - Warning lamp with display in case of exceeding maximum permissible value - Jack plug
Software	<ul style="list-style-type: none"> - Configuration of the FLYdat via PC - RS232 interface to the PC - Read out via PC (voltage of min. 10V necessary) - Windows system software - Firmware Update possible
	

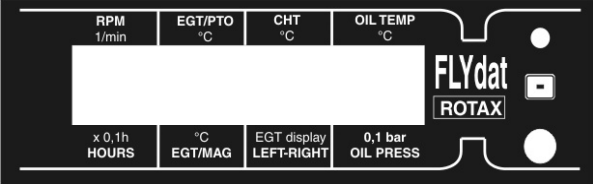
Model 2008	FLYdat part no. 886858
Characteristics	<ul style="list-style-type: none"> - 1 version (English) - Button to reset the service messages - Warning lamp with display in case of exceeding maximum threshold - USB connection
Software	<ul style="list-style-type: none"> - USB Type A-interface to the PC (read out and configuration with Standard USB connecting cable possible) - Power supply via USB connection - Windows system software - Firmware update possible
	

SECTION 78-00-00

1) Introduction of new exhaust bends an exhaust manifold on ROTAX® 914

1.1) General Information

(see fig. 1 to 2)

Owing to continuous further development, the exhaust bends were slightly re-worked. The couplings were optimized for their position.

- Position of the EGT connections (6) to the exhaust bends for cylinders 3 and 4 were routed such that installation of the new drip trays is possible.

The new exhaust bends and the new exhaust manifold have already been built into all of the following engines:

- 914 F as of S/N 4,420.364
- 914 UL as of S/N 4,418.248

parts requirement:

Fig item no	New part no	Qty per engine	Description	Old part no	application
1	979425	1	exhaust bend assy cyl. 1	979420/421/422	ROTAX® 914
2	979435	1	exhaust bend assy cyl. 2	979430/431/432	ROTAX® 914
3	979445	1	exhaust bend assy cyl. 3	979440/441/442	ROTAX® 914
4	979455	1	exhaust bend assy cyl. 4	979450/451/452	ROTAX® 914
5	979413	1	exhaust manifold	979411	ROTAX® 914

◆ NOTE: If replacement of any single old part number is necessary, you must replace it with the same old part number. If the old part number is not available, the **entire** assembly including all 4 pipes and manifold must be replaced with new part numbers. New style pipes and manifold are not interchangeable with old style.

1.2) Illustration

the following drawings should convey additional information:

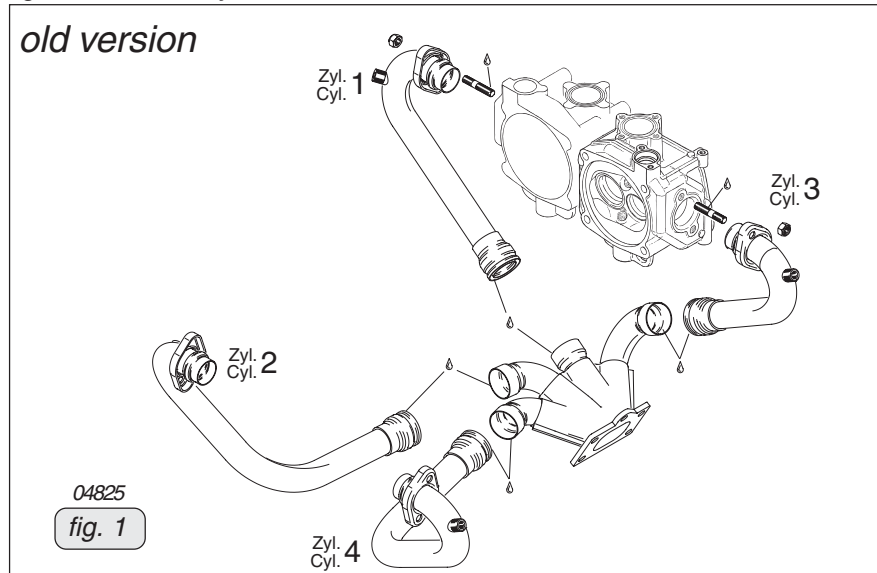

new Version

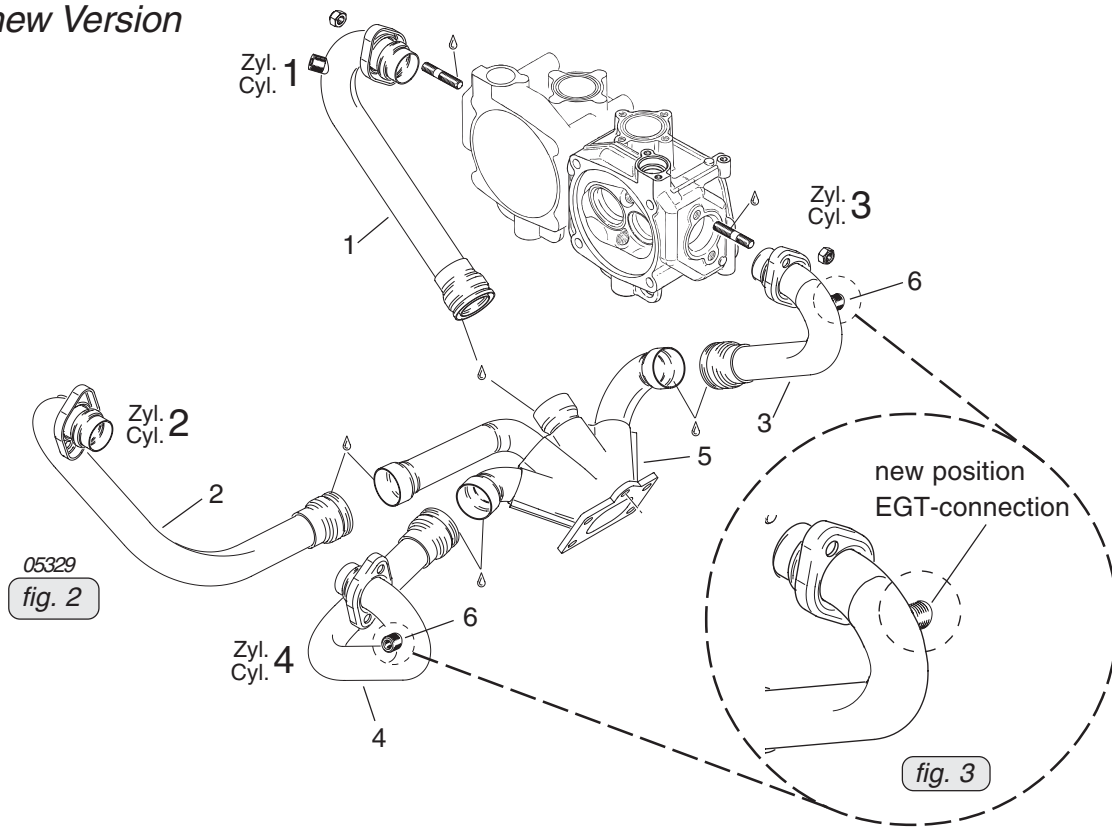

1.) Introduction of a new oil pressure sensor for ROTAX® 912/914 Series

1.1) new oil pressure sensor part no. 456180

(see fig. 1, 2, 3 and 4)

In the course of further development and standardization a new oil pressure sensor part no. 456180 has been introduced.

The new oil pressure sensor has been already installed on the following engines:

- 912 A from S/N 4 410 959 inclusive
- 912 F from S/N 4 413 009 inclusive
- 912 S from S/N 4 924 446 inclusive
- 912 UL from S/N 6 770 766 inclusive
- 912 ULS from S/N 6 780 435 inclusive
- 914 F from S/N 4 421 150 inclusive
- 914 UL from S/N 7 682 317 inclusive

1.1.1) Interchangeability of parts

The oil pressure sensor part no. 956413 can no longer supplied and has been replaced by part no. 456180.

parts requirement:

Fig item no	New part no	Qty per engine	Description	Old part no	application
1	456180	1	oil pressure sensor	956413	oil pump
-	881302	1	connector set OPS and MAPS	-	oil pressure sensor
	or				
-	864250	1	oil pressure sensor wire assy.	-	oil pressure sensor
	686250*	1	oil pump housing with sensor	-	lubrication system

* Oil pump body with mounted sensor for easy retrofit if a rework of the oil pump housing is necessary.

1.1.2) Special tooling/lubricant-/adhesives-/sealing compound - Price and availability

Price and availability will be supplied on request by ROTAX® Authorized Distributors or their Service Centers.

parts requirement:

Fig item no	New part no	Qty per engine	Description	Old part no	application
-		1	crimp tool Delphi (manufacturer no. 12155975)	-	connector set OPS and MAPS assy.
-		1	thread tap M10x1	-	oil pump housing

1.2) Retrofitting and/or new reinstallation

See current issue of Maintenance Manual Heavy.

1.3) ROTAX® Flydat

◆ NOTE: Due to a configuration of the electric oil pressure sensor on the ground are already about approx. 0.2 bar (3 psi) (depending on the sea level and ambient pressure) displayed.

1.3.1) ROTAX® Flydat part no. 886858

- The ROTAX® Flydat part no. 886858 has already been prepared for the electric oil pressure sensor concerning its hardware and software.

◆ NOTE: For more information, please contact an authorized distributor or Service Center for ROTAX® aircraft engines.

1.3.2) ROTAX® Flydat part no. 886857

- For the ROTAX® Flydat part no. 886857 a retrofit kit for the electric oil pressure sensor is offered.

◆ NOTE: For more information, please contact an authorized distributor or Service Center for ROTAX® aircraft engines.

1.3.3) old models of ROTAX® Flydat

- For older ROTAX® Flydat models as e.g. part no. 886856/886855 a retrofit is not possible.

d06376

1.4) Illustration

the following sensor characteristic and drawings should convey additional information:

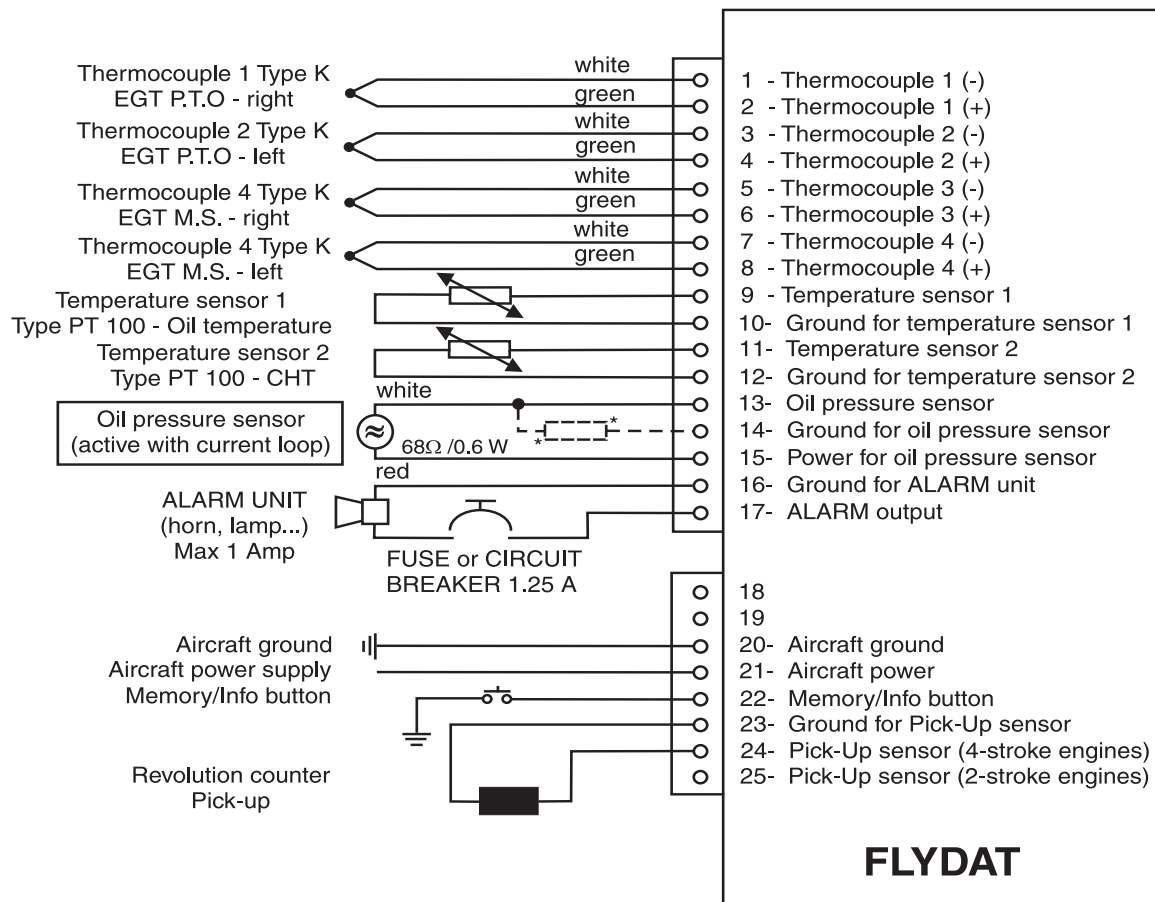

* resistor is part of the retrofit kit for Flydat part no. 886857. See also 1.3.2.

08446

fig. 1