

**SERVICE INSTRUCTION****Fuel pump assembly for ROTAX® Engine Type 912 i (Series)**

ATA System: 73-00-00 Fuel system

**1) Planning information**

To obtain satisfactory results, procedures specified in this publication must be accomplished with accepted methods in accordance with prevailing legal regulations.

BRP-Rotax GmbH & Co KG cannot accept any responsibility for the quality of work performed in accomplishing the requirements of this publication.

**1.1) Applicability**

All versions of ROTAX® engines types:

Engine type	Serial number
912 iSc Sport	all
912 iS Sport	all

**1.2) Concurrent ASB/SB/SI and SL**

In addition to this Service Instruction the following documents must be observed and complied with:

in general - all relevant Alert Service Bulletins (ASB), Service Bulletins (SB), Service Instructions (SI), Service Letters (SL), Service Instruction - Parts and Accessories (SI-PAC) with relevance to perform this maintenance, repair or overhaul task.

- ASB-915 i A-008/ASB-912 i-011, title "Replacement of fuel pump assy. for ROTAX® Aircraft Engine Type 915 i A and 912 i (Series)", current issue.
- ASB-912 i-010/ASB-915 i-006, title "Inspection and/or replacement of fuel pump assy.", current issue.
- SI-912 i-019/SI-915 i-005, title "Introduction of revised fuel pump assy. for ROTAX® Engine Type 912 i and 915 i (Series)", current issue.
- SI-PAC-008, title "Fuel pump service kit for ROTAX® Aircraft Engines", current issue.
- SI-PAC-016, title "Fuel pump assy. for ROTAX® Aircraft Engines", current issue.

**1.3) Reason**

Installation and maintenance information for Genuine ROTAX® fuel pump assy. part no. 889696 (UNF) / 889698 (Metric). See section 2.3 for packaged part numbers.

**1.4) Subject**

Fuel pump assembly for ROTAX® Engine Type 912 i (Series).

**1.5) Compliance**

None - For Information Only.

**1.6) Approval**

The technical content of this document is approved under the authority of the DOA ref. EASA.21J.048.

# SERVICE INSTRUCTION

---

## 1.7) Labor time

Estimated labor hours:

Engine installed in the aircraft - - - labor time will depend on airframe installation and therefore no estimate is available from the engine manufacturer.

## 1.8) Mass data

Change of weight - - - none.

## 1.9) Electrical load data

See section 3.2.

## 1.10) Software modifications

No change.

## 1.11) References

In addition to this technical information refer to current issue of

- in general Operators Manual (OM)
- in general Illustrated Parts Catalog (IPC)
- in general Installation Manual (IM)
- in general Maintenance Manual Line (MML)
- in general Maintenance Manual Heavy (MMH) and in particular:  
Chapter 73-00-00

NOTE: The status of the Manuals can be determined by checking the table of amendments. The 1<sup>st</sup> column of this table shows the revision status. Compare this number to the one listed on the ROTAX® website:  
[www.flyrotax.com](http://www.flyrotax.com). Updates and current revisions can be downloaded for free.

## 1.12) Other Publications affected

None.

## 1.13) Interchangeability of parts

- not affected

# SERVICE INSTRUCTION

## 2) Material Information

### 2.1) Material- cost and availability

Price and availability will be provided on request by ROTAX® Authorized Distributors or their independent Service Centers.

### 2.2) Company support information

- Any possible support by BRP-Rotax will be provided on request by ROTAX® Authorized Distributors or their independent Service Centers.

### 2.3) Material requirement per engine

Parts requirement:

Part no.	Qty/engine	Description	Application
889697	(1)	Fuel pump assy. UNF packaged (889696 + 3x 850620 + packaging)	Airframe fuel system
889699	(1)	Fuel pump assy. METRIC packaged (889698 + 3x 850620 + packaging)	Airframe fuel system
889537	AR	Fuel pump service kit (includes all rubber hoses and clamps necessary for 5 year rubber replacement)	Fuel pump assy. repair / maintenance, see SI-PAC-008, title "Fuel pump service kit for ROTAX® Aircraft Engines", current issue
481378	AR	Replacement kit - single fuel pump (includes 1x fuel pump and all necessary rubber hoses and clamps to replace a single pump)	Exchange of fuel pump(s) within pump assy.

### 2.4) Material requirement per spare part

None.

### 2.5) Rework of parts

None.

d06905.fm

## SERVICE INSTRUCTION

### 2.6) Special tooling/lubricants- /adhesives- /sealing compounds

Price and availability will be supplied on request by ROTAX® Authorized Distributors or their independent Service Centers:

Description	Part no.	Application
KNIPEX 1099 pliers (or similar OETIKER type pliers)*	-	Fuel pump service. Crimp connections
CRC Leak Detector (14503)*. Non-flammable water-based formula. No oils, silicones or harmful solvents	-	Fuel pump service. Crimp connection leak detection
BERNER "Leckfinder" (148383)*. Water based formula, non-corrosive, silicone free.	-	Fuel pump service. Crimp connection leak detection

\*) or equivalent

NOTE: There are many third-party commercial leak detection products available. Ensure that the leak detection solution used is non-corrosive and does not contain harmful solvents.

#### **NOTICE**

If using these special tools observe the manufacturers specifications.

# SERVICE INSTRUCTION

## 3) Accomplishment/Instructions

- ROTAX reserves the right to make any amendments to existing documents which might become necessary due to this standardization, at the time of next revision or issue.

NOTE: Before maintenance, review the entire documentation to make sure you have a complete understanding of the procedure and requirements.

### Accomplishment

All measures must be implemented and confirmed by at least one of the following persons or organizations:

- ROTAX® - Airworthiness representatives
- ROTAX® - Authorized Distributors or their independent Service Centers
- Persons approved by the respective Aviation Authority
- Persons with approved qualifications for the corresponding engine types. Only authorized persons (iRMT, Level Heavy Maintenance) are entitled to carry out this work.



See current Installation Manual (IM) for the respective engine type.

### General

Further material on general inspection, maintenance and repair can also be found in relevant Advisory Circular AC 43.13 from FAA.

### Advisory Circular

The Advisory Circular (AC) contains maintenance methods, techniques and practices.

### 3.1) Spare Parts - related information



See current Illustrated Parts Catalog (IPC) for the respective engine type.

### 3.2) Installation - related information



See current Installation Manual (IM) for the respective engine type.

NOTE: The Genuine ROTAX® fuel pump assy. has been tested and approved according to CS-E-130. Thus, the fuel pump assy. can be installed on the firewall without additional fire protection.

The electrical fuel pump must be installed near the tank and away from potential sources of heat to ensure a safe fuel supply, and minimize the risk of vapor lock.

NOTE: If the length of the power supply wire is insufficient, it can be extended. A ROTAX® connector set is available.

### NOTICE

Do not connect additional load (additional fuel pumps, lamps, LED, etc.) to the power supply of the fuel pumps.  
The wiring is manufactured for the Genuine ROTAX® fuel pump assy. only.

d06905.fm

# SERVICE INSTRUCTION

Current input (Operating condition of the fuel pumps: ON)	
912 i (Series)	
Voltage	Current
12 V	-
14 V	10.1 A
13.8 V	-

Step	Procedure
1	Remove the negative terminal of the battery.
2	Install the fuel pump assy. to the aircraft. NOTE: The position and type of positioning and attachment of the fuel pump depends on the aircraft type. See aircraft manufacturer documentation.
3	Loosen 4 Allen screws M5 and remove the fuel pump assy. cover.
4	Connect the wiring harness connectors to the appropriate fuel pumps. NOTE: Check the color of the engine wiring harness connector gaskets (orange must be present). If seals are of any other color, follow instructions in SI-912 i-019/SI-915 i-005 (latest version), section 3.2 to replace with revised connector gaskets.

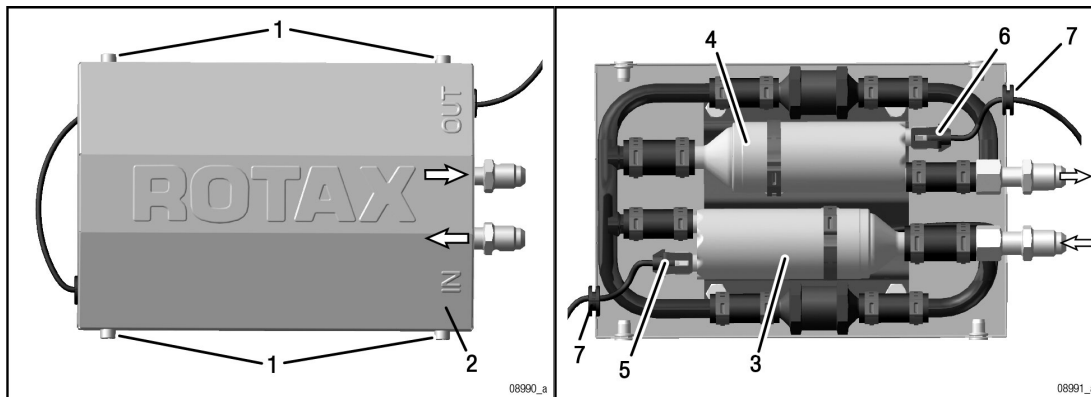

- 1 Allen screws M5x12
- 2 Cover
- 3 Fuel pump (main)
- 4 Fuel pump (auxiliary)
- 5 Connector (main pump)
- 6 Connector (aux. pump)
- 7 Grommets

Fig. 1

d06905.fm

# SERVICE INSTRUCTION

Step	Procedure
5	Connect the fuel inlet and outlet. NOTE: Hold the fuel inlet and fuel outlet connections with a wrench on the fuel pump side while tightening fittings. NOTE: Torque for fuel hose connections depends upon factors such as connector type, material and design, therefore ROTAX® cannot provide torque values.
6	Insert grommets over fuel pump wiring at the housing edges.
7	Place cover carefully over grommets and fix with 4 Allen screws M5. Tightening torque 6 Nm (53 in. lb.)

**NOTICE** Inlet and outlet fuel fittings on fuel pump assy, and the engine fuel rail inlet and outlet fittings are material 1.4305 (X8CrNiS18-9).

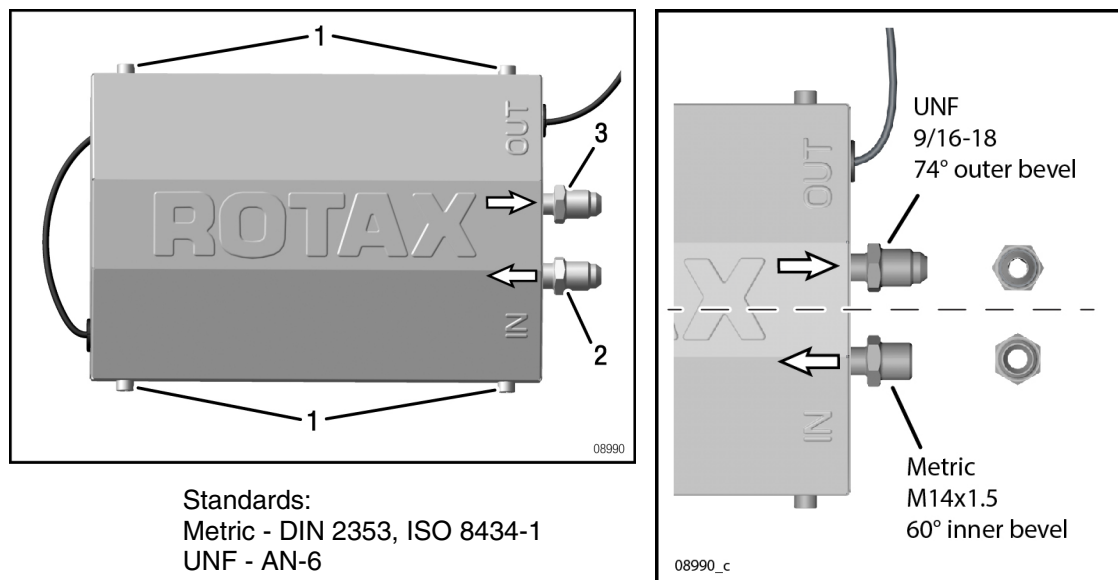

- 1 Allen screws M5x12
- 2 Fuel inlet
- 3 Fuel outlet

Fig. 2

d06905\_fm

# SERVICE INSTRUCTION

## 3.3) Operation - related information

### 3.3.1) Operating instruction



See current Operators Manual (OM) for the respective engine type.

## 3.4) Maintenance (Line) - related information

Points of inspection	Interval Operating hours		Chapter Reference
	100 h	200 h	
General visual inspection of the fuel pump assy. for damage, leaks, corrosion or abnormalities.	X		See relevant Maintenance Manual (Line) for the respective engine type and its periodical maintenance information.
Inspect the fuel pumps. - Remove the housing - Visual inspection of lines and connections - Check for leaks - Check for corrosion		X	

### NOTICE

Avoid over-tightening the fastening elements. Use a suitable torque wrench for all work.

### NOTICE

All rubber parts in the supply scope of ROTAX® must be replaced after a maximum of 5 years.  
See Maintenance Manual Line (MML) Chapter 05-10-00 section: 2.1).

## 3.5) Maintenance (Heavy) - related information

**NOTE:** Before accomplishment, review the entire documentation to make sure you have a complete understanding of the procedure and requirements.



See current Maintenance Manual Heavy (MMH) for the respective engine type.

### 3.5.1) Fuel pump assy. - removal

It is recommended to perform any fuel pump assy. maintenance on an assy. that has been removed from the aircraft.



Drain the fuel. See current Maintenance Manual Line (MML) for the respective engine type, Chapter 12-20-00 section Planned maintenance.

d06905.fm



# SERVICE INSTRUCTION

Step	Procedure
1	Remove the negative terminal of the battery.
2	Disconnect the fuel inlet and outlet hoses. NOTE: Hold the fuel inlet and fuel outlet connections with a wrench on the fuel pump side while loosening fittings.
3	Dis-connect the wiring harness connectors from the fuel pumps (main, aux): - Lift the latches - Unplug the connectors
4	Remove the fuel pump assy. from the aircraft according to the aircraft manufacturer's manual.

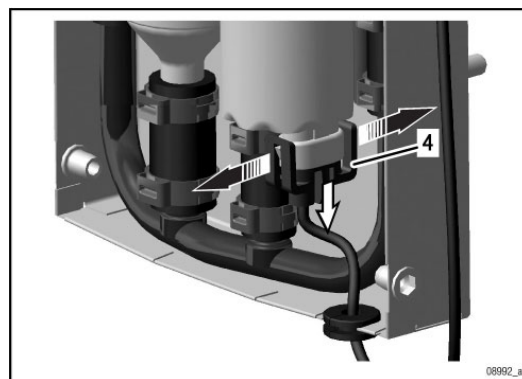
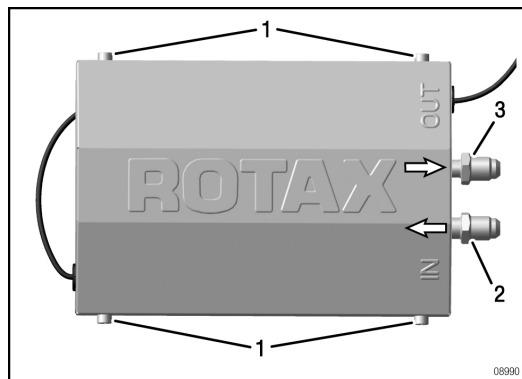

- 1 Allen screws M5x12
- 2 Fuel inlet
- 3 Fuel outlet
- 4 Connector

Fig. 3

### 3.5.2) Fuel pump assy. - disassembly

Step	Procedure
1	Loosen the 4 hex. nut M6 and take the fuel pump assy. out of the housing.

d06905.fm

# SERVICE INSTRUCTION

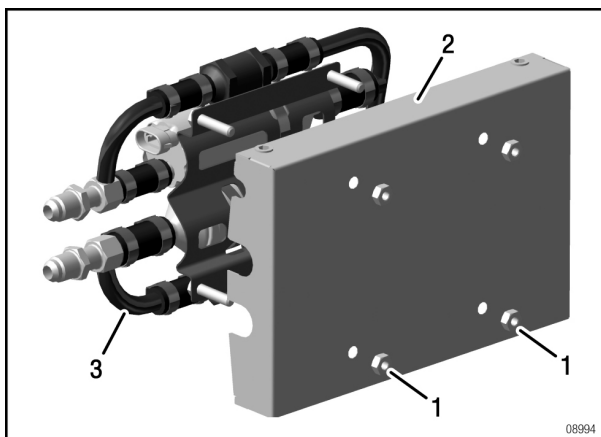

- 1 Hex. nut M6
- 2 Housing
- 3 Fuel pump assy.

Fig. 4

Step	Procedure
2	Remove 1-ear clamps (Fig. 6, pos 2, 3 and 4). NOTE: Use e.g. ear clamp pliers KNIPEX 1099 or equivalent. Position jaws of the pliers on the edge of ear and cut through the ear of each clamp. Then use pliers to spread and remove the clamp.

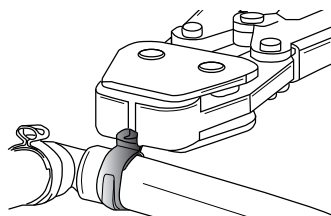

1. Place jaw tips on each side of clamp ear or single leg

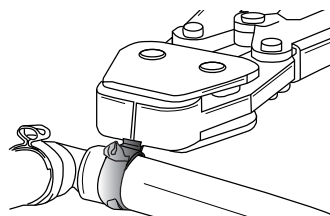

2. Squeeze handles

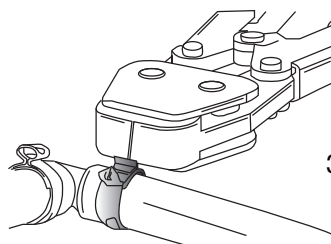

3. Cut through and remove clamp

Fig. 5

d06905.fm

# SERVICE INSTRUCTION

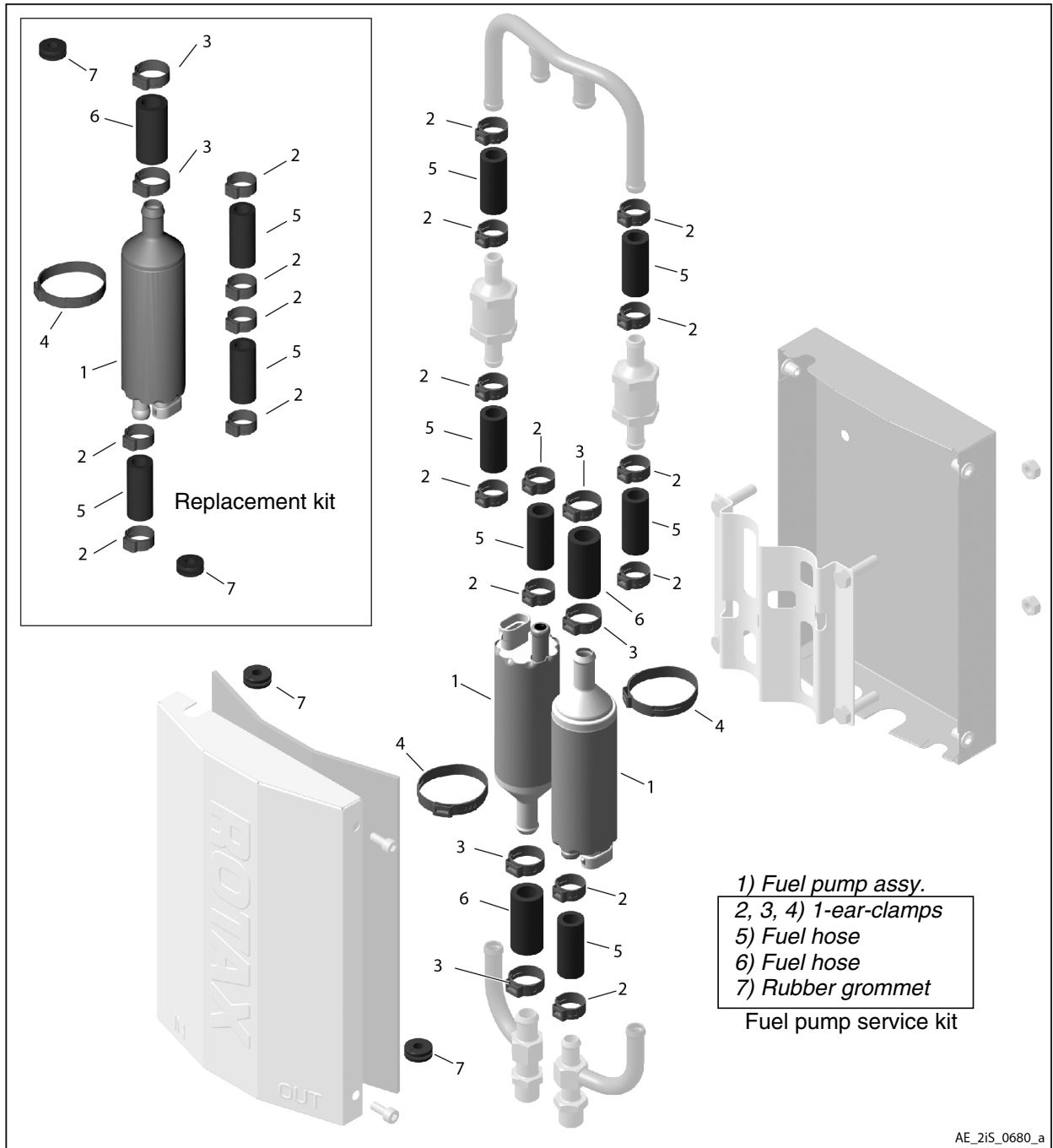

Fig. 6

d06905.fm

## SERVICE INSTRUCTION

Step	Procedure
3	Remove pump bracket assy.
4	Disassemble the fuel hose suction line, pressure line, connecting line, check valve, fuel pumps. NOTE: Do not damage fuel pump and check valve connectors during disassembly process. Do not use a knife or sharp object as this may cut, scratch or otherwise damage the fitting.

### 3.5.3) Fuel pump assy. - Checks

Step	Procedure
1	Check the fuel pump connectors for deformation, cuts or scratch marks. NOTE: Longitudinal cuts or scratches are not allowed. If such marks are found the fuel pump must be replaced.
2	Check the suction line, pressure line, connecting line and check valve for deformation or scratch marks. NOTE: Longitudinal cuts or scratches are not allowed. If such marks are found the check valve or connecting line must be replaced.
3	Check the entire system for deposits and/or contamination in the lines, fuel pumps etc.
4	Visual check of all fuel pump assy. components (cover, brackets, housing, heat protection mat etc.).

### 3.5.4) Fuel pump assy. - Assembly



Only use Genuine ROTAX® parts for replacement!  
See current Illustrated Part Catalog (IPC) for the respective engine type.

NOTE: Always use new hoses for assembly.

NOTE: For easier hose assembly, fuel or brake cleaner can be used to lubricate the inside of the hose. Do not use oil, silicone or any type of grease!

NOTE: Make sure that all 1-ear-clamps are crimped with 1.5 mm (0.06 in.) distance from hose end and are not positioned directly over the connector barb (see Fig. 7).

NOTE: Always use full slip on length of the hoses (see Fig. 7).

NOTE: Assemble with clean parts only in a clean environment!

NOTE: Ensure that check valves and fuel pumps are in their correct orientation.

d06905.fm

# SERVICE INSTRUCTION

NOTE: The fuel pumps and check valves must not be dismantled. Replace at maintenance interval or when contaminated.

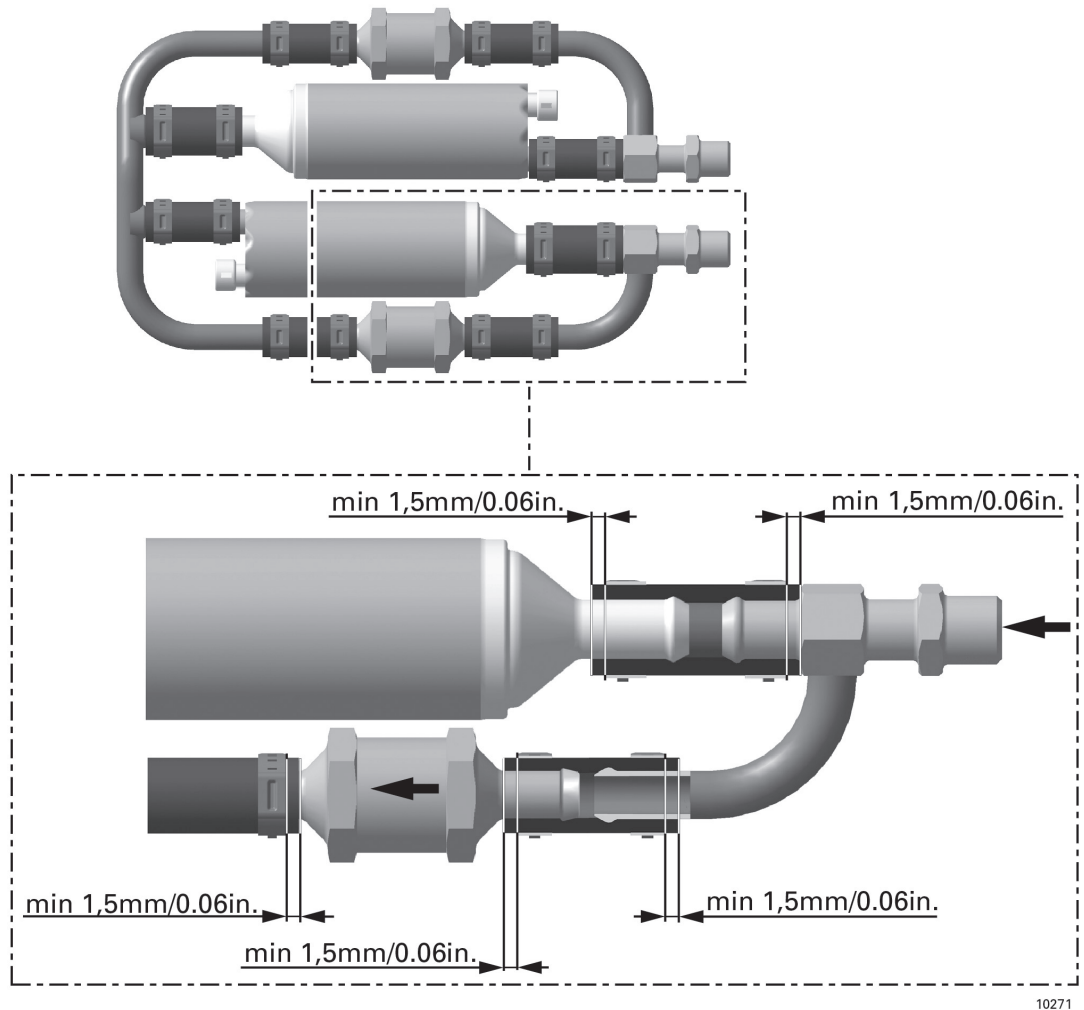

10271

Fig. 7

d06905.fm

## SERVICE INSTRUCTION

See Fig. 8

Step	Procedure
1	Position new hoses (10, 12) on connection line (15).
2	Slip on new 1-ear-clamps (11, 13).
3	Install the check valves (14) and the fuel pumps (8).
4	Position new hoses (10, 12) on check valves (14) and the fuel pumps (8).
5	Install new 1-ear-clamps (9) on the pump bracket assy. (2).
6	Slide in the check valves and fuel pumps accordingly.
7	Slip on new 1-ear-clamps (11, 13).
8	Install suction line (16).
9	Install pressure line (17).
10	Temporarily position complete fuel pump assy. (pump bracket assy. (2) with fuel pumps (8) etc.) in the fuel pump housing (1).
11	Arrange the position of the fuel pumps, check valves, hoses, clamps, etc. accordingly to fit in the fuel pump housing.
12	Mount and crimp the two fuel pump 1-ear-clamps (9) in their original position and orientation to fit in the fuel pump housing and be within the area of positioning on the fuel pump housing.  NOTE: Use e.g. ear clamp pliers KNIPEX 1099 or equivalent. If using these special tools observe the manufacturers specifications (force, open "ear" gap width to be used for relevant clamps).
13	For easier work on the consequent job tasks, remove the complete fuel pump assy. from the fuel pump housing without relocating hoses, check valves, fuel pumps etc.
14	Mount and crimp 1-ear-clamps (11, 13).  NOTE: Use e.g. ear clamp pliers KNIPEX 1099 or equivalent. If using these special tools observe the manufacturers specifications (force, open "ear" gap width to be used for relevant clamps).
15	Place complete fuel pump assy. (pump bracket assy. (2) with fuel pumps (8), etc.) in the fuel pump housing (1).
16	Install hex. nuts M6 (3). Tightening torque 10 Nm (90 in. lb.).
17	Before installing the fuel pump cover (4), perform a leakage check (see section 3.5.5).
18	Install the wiring and rubber grommets (6) into fuel pump housing (1).
19	Connect electrical connectors to MAIN and AUX fuel pump (8).
20	Install fuel pump cover (4) using 4 Allen screws M5x12 (7). Tightening torque 6 Nm (55 in. lb.).

d06905.fm

# SERVICE INSTRUCTION

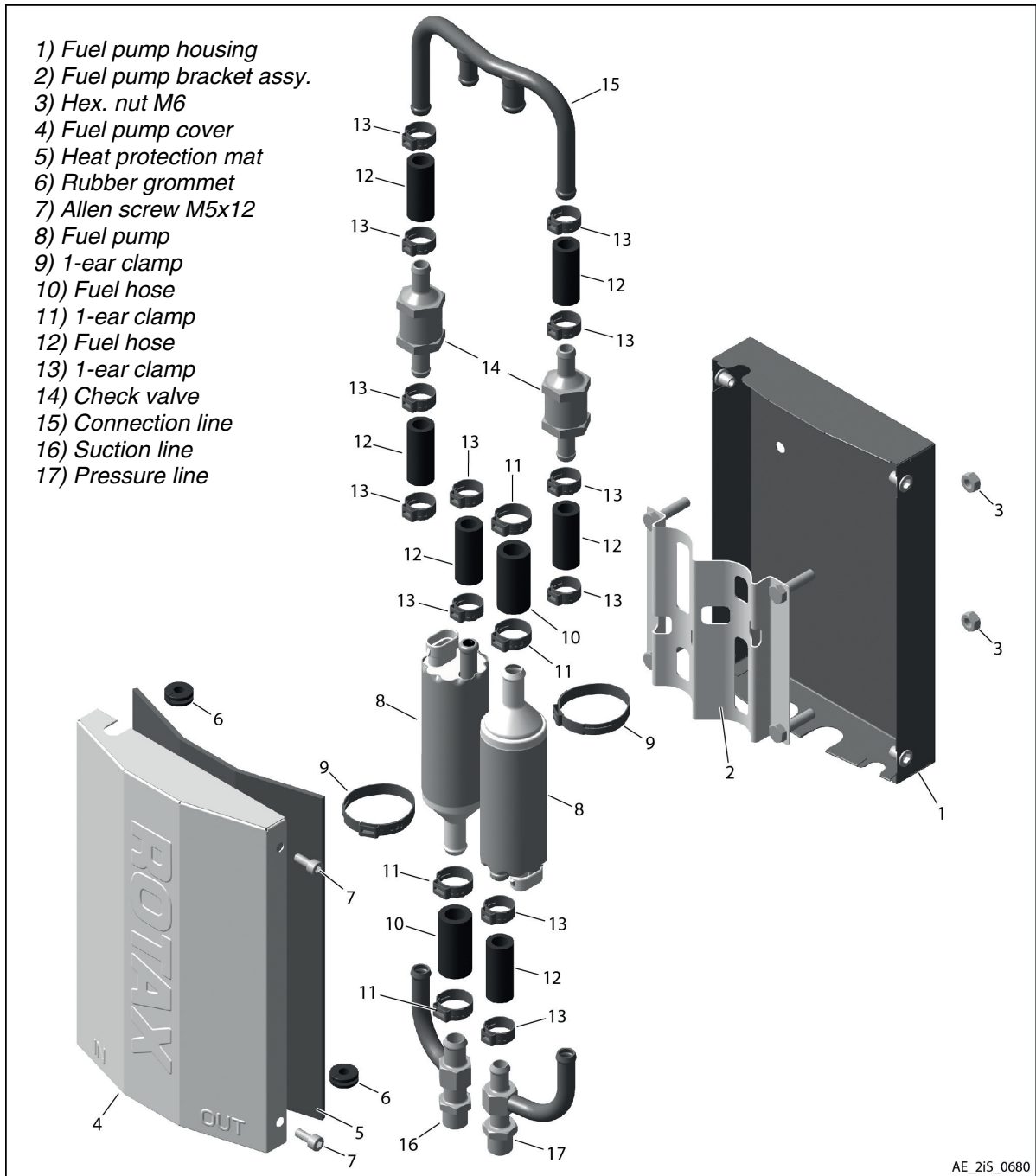

Fig. 8

d06905.fm

## SERVICE INSTRUCTION

### 3.5.5) Fuel pump assy. - Leakage check

Once all rubber hoses have been replaced and all clamps are properly crimped, the connections of the fuel pump assembly must be checked.



See current Maintenance Manual Heavy (MMH) for the respective engine type.

#### NOTICE

Make sure not to mix up IN (Fuel IN) and OUT (Fuel OUT) of fuel pump assembly in the following tasks.

#### NOTICE

For this leakage check disconnect electrical connectors to MAIN and AUX fuel pump.

Step	Procedure
1	Block the OUTLET of the fuel pump assembly with suitable threaded pressure cap (e.g. AN929-6).
2	Connect the INLET of the fuel pump assembly to a differential pressure gauge.
3	Apply 6 bar (87 psi) to the fuel pump assy.
4	NO pressure loss is allowed on the differential pressure gauge.
5	With the fuel system temporarily pressurized with air, use an appropriate leak detector solution at each hose and clamp connection to verify proper sealing.

#### NOTICE

Follow leak detector solution manufacturer's instructions for its use, clean up and safety information.

Step	Procedure
6	If any air bubbles are present at rubber hose connections, replace the clamp and ensure proper crimp.

d06905.fm



# SERVICE INSTRUCTION

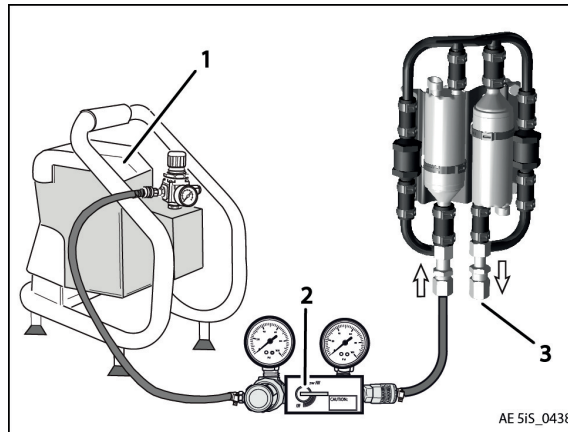

1 Air compressor  
2 Differential pressure tester  
3 Cap on "Outlet"

Fig. 9

### 3.6) Test run

In case of uninstalled engines test run can be skipped as this is covered by the mandatory test run after installation.



Conduct engine test run and perform leakage check. See current Maintenance Manual Line (MML) for the respective engine type, Chapter 12-20-00.

### 3.7) Summary

The execution of the Service Instruction must be confirmed in the logbook.

**NOTE:** Work on EASA certified parts might affect the EASA Form 1 and does require appropriate documentation by authorized persons. Repairs must be entered into the engine logbook and also do apply for the EASA Form 1.

| A revision bar outside of the page margin indicates a change to text or graphic.

Translation into other languages might be performed in the course of language localization but does not lie within ROTAX' scope of responsibility.

In any case the original text in English language and the metric units are authoritative.

### 3.8) Inquiries

Inquiries regarding this Service Instruction should be sent to the ROTAX® Authorized Distributor of your area.

A list of all ROTAX® Authorized Distributors or their independent Service Centers is provided on <https://dealerlocator.flyrotax.com>.

# SERVICE INSTRUCTION

## 4) Appendix

The following drawings/schematics/tables should convey additional information:

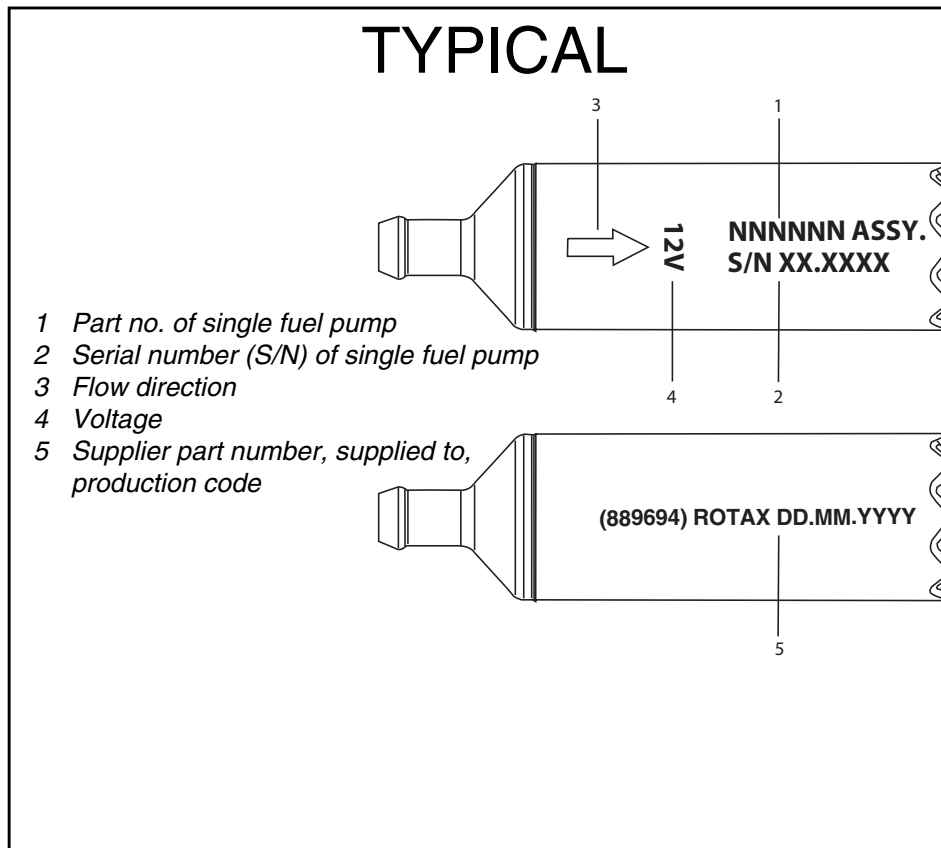

AE\_14\_206\_a

Fig. 10

d06905.fm

# SERVICE INSTRUCTION

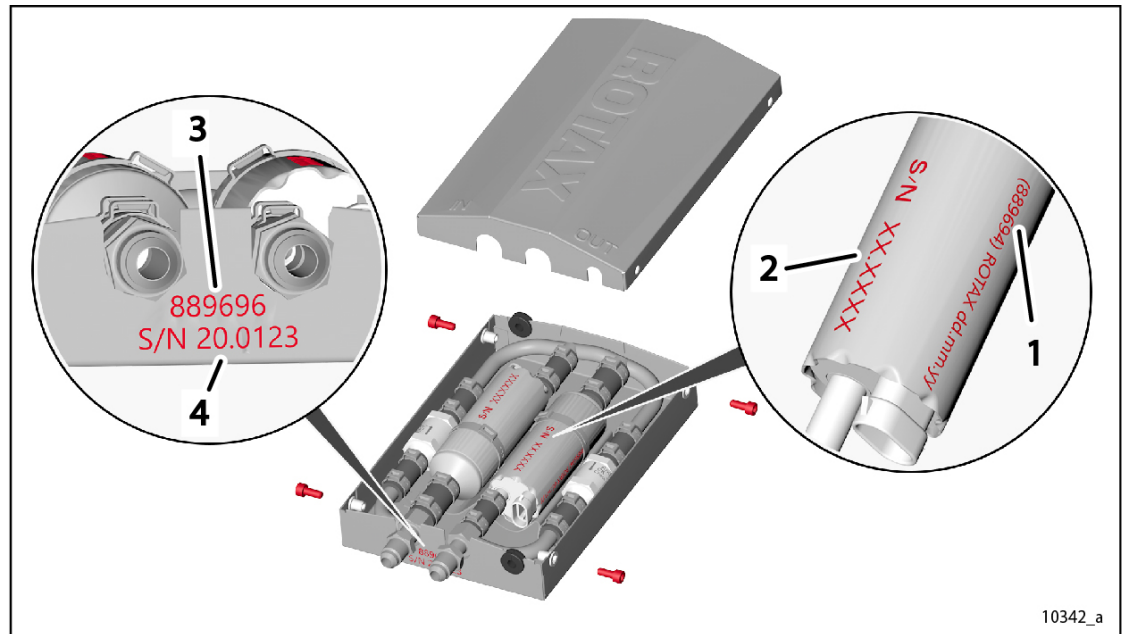

- 1 Part no. of single fuel pump, see Fig. 10
- 2 Serial number (S/N) of single fuel pump, see Fig. 10
- 3 889696 for UNF or 889698 for metric
- 4 S/N of complete fuel pump assy. (housing, fuel pumps,...)

Fig. 11

10342\_1

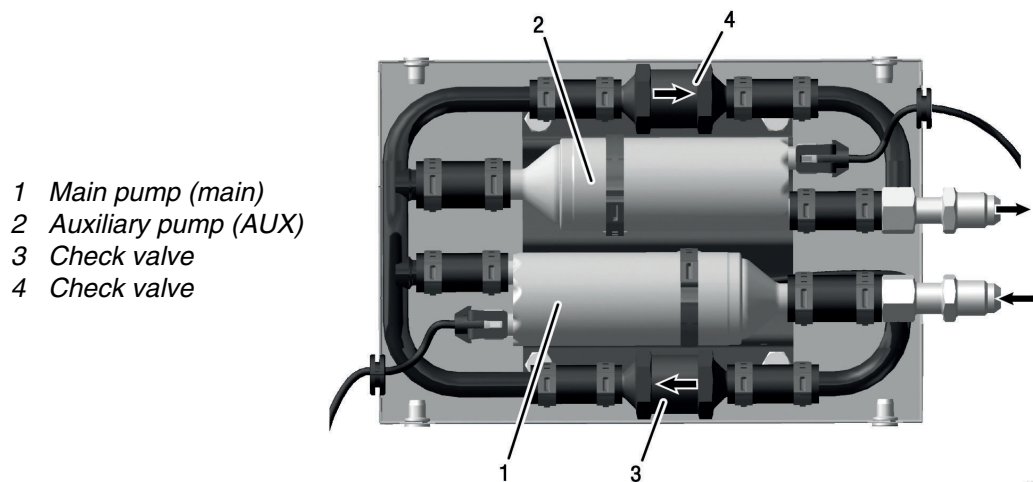
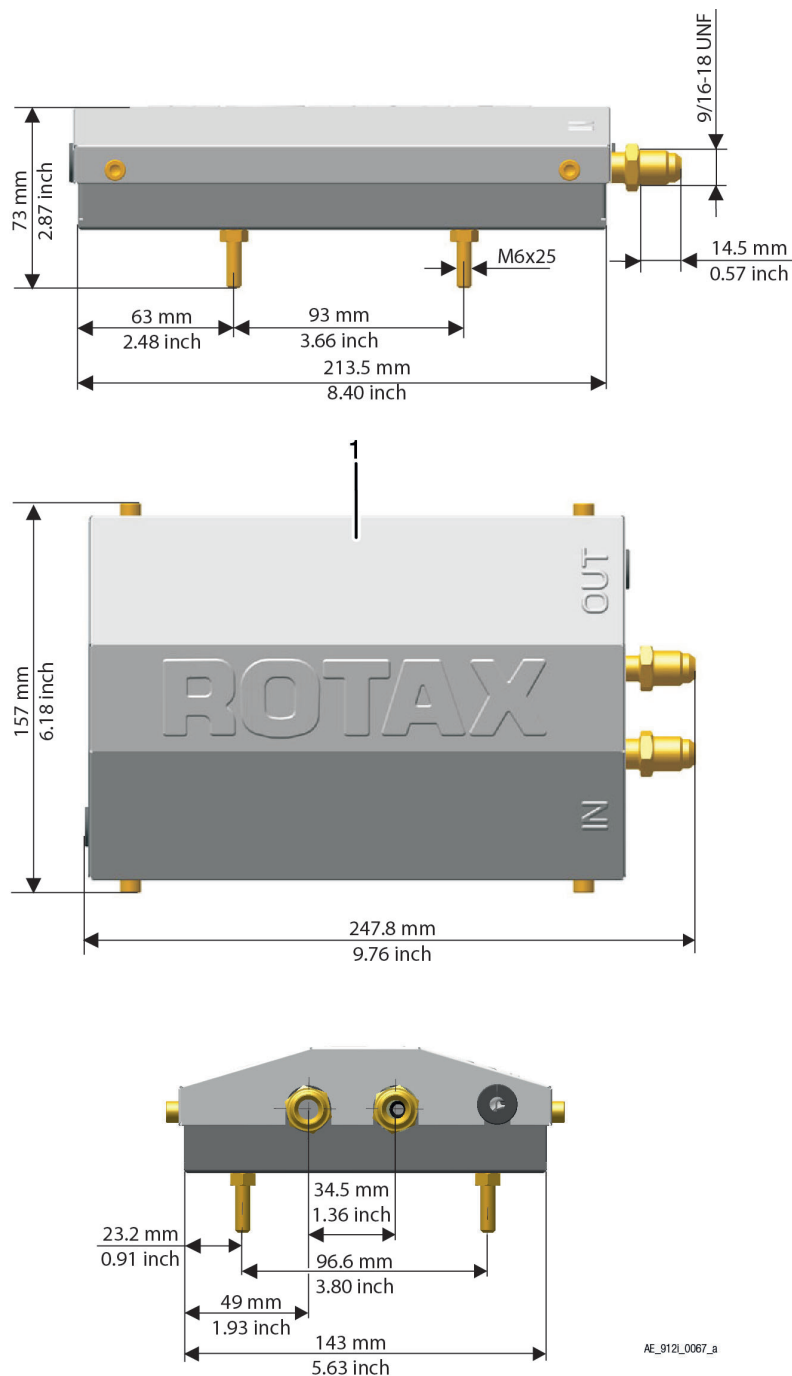

Fig. 12

d06905.fm

# SERVICE INSTRUCTION



1 Fuel pump assy.  
(UNF, AN-6,  
outer bevel 74°)

Fig. 13

d06905.fm

# SERVICE INSTRUCTION

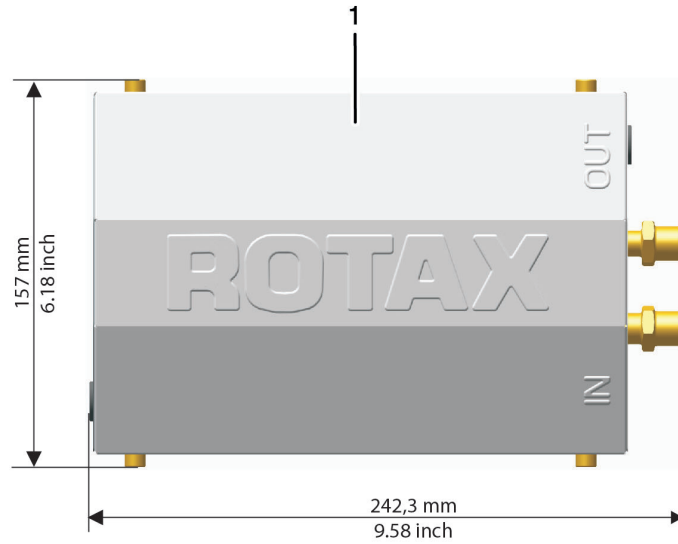
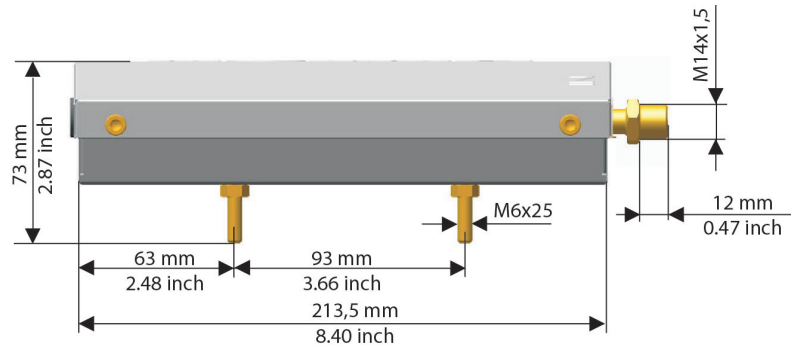

1 Fuel pump assy.  
(METRIC, DIN 2353  
ISO 8434-1, inner  
bevel 60°)

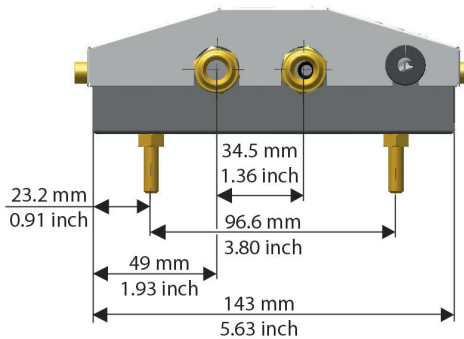

AE\_912i\_0068\_a

Fig. 14

NOTE: The illustrations in this document show the typical construction. They may not represent full detail or the exact shape of the parts which have the same or similar function.

Exploded views are **not technical drawings** and are for reference only. For specific detail, refer to the current documents of the respective engine type.

d06905.fm