

# SERVICE INSTRUCTION - PAC

## Governor flange cover and installation / use of governors for ROTAX® Aircraft Engines

ATA System: 61-20-00 Hydraulic governor

### 1) Planning information

“PAC” Service Instruction Documents provide detailed information on ROTAX® Aircraft Engine Parts and Accessories. Depending on the engine type used with referenced parts and accessories may be provided with or without EASA certification or ASTM compliance. Certification / Compliance of referenced Parts and Accessories must in such cases be completed by the aircraft OEM.

To obtain satisfactory results, procedures specified in this publication must be accomplished with accepted methods in accordance with prevailing legal regulations.

BRP-Rotax GmbH & Co KG cannot accept any responsibility for the quality of work performed in accomplishing the requirements of this publication.

#### 1.1) Applicability

Refer to the latest issue of the relevant Illustrated Parts Catalog of your specific engine type.

#### NOTICE

The governor flange cover may be declared as part of the hydraulic governor on by the aircraft OEM and so might not be a part of the Engine Type Design. Such a PAC part has been then tested and released by BRP-Rotax, but it might not be certified for the relevant engine type. In such a case the correct function in conjunction with the entire system is the responsibility of the aircraft manufacturer and must be carried out jointly with the aircraft.

#### 1.2) Concurrent ASB/SB/SI and SL

In addition to this Service Instruction - PAC the following Service Bulletin must be observed and complied with:

Service Bulletin-SB-912 i-001/SB-912-052/SB-914-035, title „Installation/Use of governors“, current issue.

#### 1.3) Reason

- The governor flange cover is provided as a protective cover for transportation only for configuration 3 and is not a part of the Engine Type Design. The governor flange cover must be replaced by a functional governor or converted to configuration 2 before the engine is run
- Replacement/Retrofitting under selection of different governors type and manufacturers

#### 1.4) Subject

Governor flange cover and installation / use of governors for ROTAX® Aircraft Engines.

#### 1.5) Compliance

NONE - For Information Only.

#### 1.6) Approval

None.

# SERVICE INSTRUCTION - PAC

---

## 1.7) Labor time

Estimated labor hours:

Engine installed in the aircraft - - - labor time will depend on airframe installation and therefore no estimate is available from the engine manufacturer.

## 1.8) Mass data

Change of weight - - - none.

Moment of inertia - - - unaffected.

## 1.9) Electrical load data

No change.

## 1.10) Software modifications

No change.

## 1.11) References

In addition to this technical information refer to current issue of

- Operators Manual (OM)
- Illustrated Parts Catalog (IPC)
- Installation Manual (IM)
- Maintenance Manual Line (MML)
- Maintenance Manual Heavy (MMH)

NOTE: The status of the Manuals can be determined by checking the table of amendments. The 1<sup>st</sup> column of this table shows the revision status. Compare this number to the one listed on the ROTAX Website:  
[www.flyrotax.com](http://www.flyrotax.com). Updates and current revisions can be downloaded for free.

## 1.12) Other Publications affected

None.

## 1.13) Interchangeability of parts

Not affected.

d06689.fm

# SERVICE INSTRUCTION - PAC

---

## 2) Material Information

### 2.1) Material- cost and availability

The governors are not directly supplied by ROTAX® Authorized Distributors or their independent Service Centers. They can be obtained via the sales network of the respective manufacturer.

### 2.2) Company support information

- Any possible support by BRP-Rotax will be provided on request by ROTAX® Authorized Distributors or their independent Service Centers.

### 2.3) Material requirement per engine

The amount of new parts required for installation of the respective governor type is indicated by the manufacturer of the governor.

### 2.4) Material requirement per spare part

None.

### 2.5) Rework of parts

None.

### 2.6) Special tooling/lubricants- /adhesives- /sealing compounds

None.

d06689.fm

# SERVICE INSTRUCTION - PAC

## 3) Accomplishment/Instructions

- ROTAX reserves the right to make any amendments to existing documents which might become necessary due to this standardization, at the time of next revision or issue.

NOTE: Before maintenance, review the entire documentation to make sure you have a complete understanding of the procedure and requirements.

### Accomplishment

All measures must be implemented and confirmed by at least one of the following persons or organizations:

- ROTAX® - Airworthiness representatives
- ROTAX® - Authorized Distributors or their independent Service Centers
- Persons approved by the respective Aviation Authority
- Persons with approved qualifications for the corresponding engine types. Only authorized persons (iRMT, Level Line Maintenance) are entitled to carry out this work.

Governors are not part of the engine. Governors specifically developed for this engine can be ordered. Furnishing proof according to the latest manufacturing specifications such as FAR and EASA shall be made by the aircraft or airframe manufacturer or the governor manufacturer.

### 3.1) Spare Parts - related information



See relevant Illustrated Parts Catalog for the respective engine type, Chapter 61-20-00.

### 3.2) Installation - related information

#### 3.2.1) Technical data

##### Governor flange

AND20010.

##### Governor drive

Internal toothing 20/40 SMS 1834 NA 14x1.27x30x12.

##### Reduction ratio

0.58 of the engine speed at gearbox with  $i = 2.27$ .

0.54 of the engine speed at gearbox with  $i = 2.43$ .

0.39 of the engine speed at gearbox with  $i = 2.54$ .

##### Direction of rotation

Direction of rotation of governor drive: Clockwise rotation seen on the attachment flange.

# SERVICE INSTRUCTION - PAC

### 3.3) Operation - related information

**General** Depending on the design/construction control cable of the governor, one of the flanges from intake manifold can be used (Fig. 1) for the installation of a support.

**Operating limits**

Power consumption of the hydraulic propeller governor	
Max.	600 W

Fig. 1

1 Flange from intake manifold 2/4

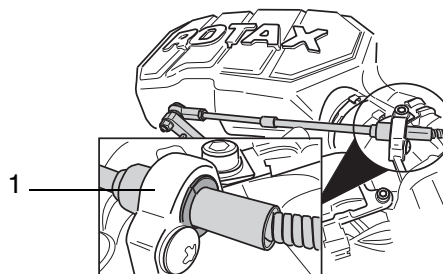

Detail: Flange from intake manifold 2/4

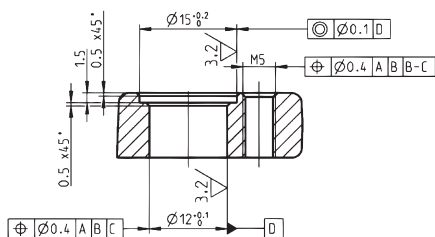

Detail: Flange from intake manifold 1/3

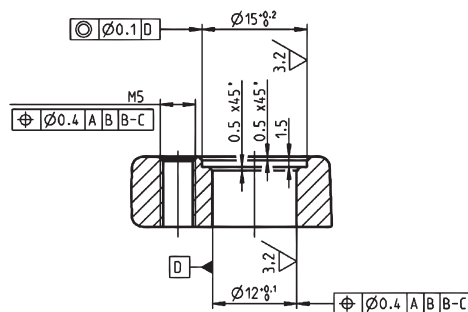

### 3.4) Maintenance (Line) - related information

Points of inspection	Interval Operating hours		Chapter Reference
	100 h	200 h	
Check for chafing or wear on the governor arm, governor cable, bushing halves and intake manifold connection point		X	See relevant Maintenance Manual (Line) for the respective engine type and its periodical maintenance information. NOTE: Observe the governor and governor cable manufacturer's installation instructions and specifications.



Follow the governor manufacturer's instructions for maintenance, inspection and repair.

d06689.fm

# SERVICE INSTRUCTION - PAC

## 3.5) Maintenance (Heavy) - related information

### Safety information



**WARNING**

Follow the general safety instructions during all work on the engine and the assemblies around it.



Follow the governor manufacturer's instructions for maintenance, inspection and repair.

### 3.5.1) Preparation

- General visual inspection.



See relevant Maintenance Manual Line for respective engine type.

### 3.5.2) Governor flange cover - removal

See Fig. 2.

Step	Procedure
1	Loosen 4 Allen screws M8x20 along with lock washers A8 and washers 8.4.
2	Remove the cover and the gasket.

Fig. 2.

- 1 Governor flange
- 2 Cover
- 3 Gasket
- 4 Lock washer A8
- 5 Washer 8.4
- 6 Allen screws M8x20

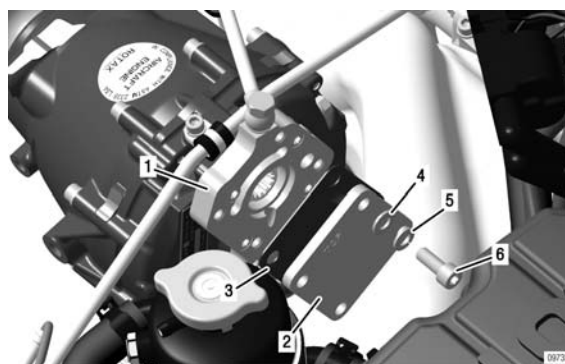

d06689.fm

# SERVICE INSTRUCTION - PAC

## 3.6) Governor - installation

For the 912 i and 915 i Series engines.

**NOTE:** Check your selected governor type for proper some governors will not fit. Use and specification due to their length.

**NOTICE** Various screws and nuts are required, depending on the manufacturer of the governor.



Refer to the information of the governor aircraft manufacturer on installation, function, operation and maintenance of the governor.

### Governor flange

See Fig. 3.

Thread length	
Min. 8 mm (0.31 in.)	Max. 14 mm (0.55 in.)

Tightening torque of the attachment screws/studs according the governor aircraft manufacturer.

Fig. 3.

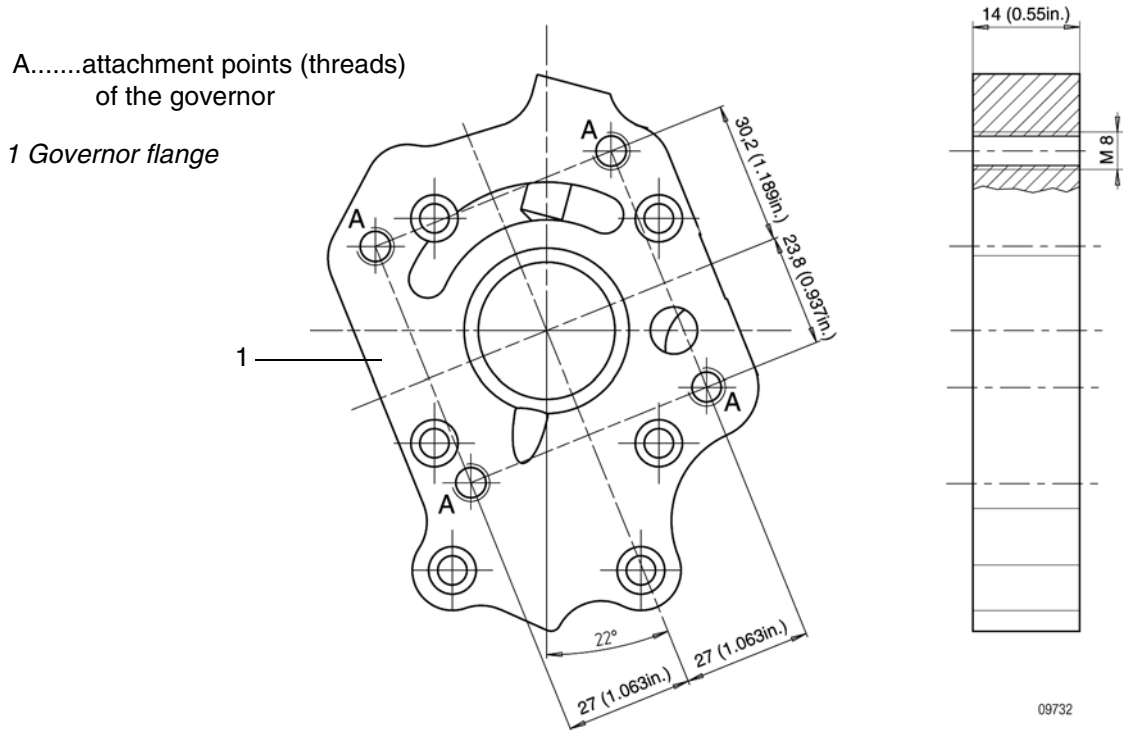

- Restore aircraft to original operating configuration
- Purge the lubrication system according to the current Maintenance Manual and Service Instruction SI-912 i-004/SI-915 i-003/SI-912-018/SI-914-020, current issue (if the lubrication system was opened or drained during maintenance work)
- Connect negative terminal of aircraft battery

d06689.fm

# SERVICE INSTRUCTION - PAC

---

## 3.7) Check of governor

Operational test of the governor as per specification of the Flight Manual and governor aircraft manufacturer.

## 3.8) Test run

In case of uninstalled engines test run can be skipped as this is covered by the mandatory test run after installation.



Conduct test run. See chapter 12-20-00 of the latest Maintenance Manual Line for the respective engine type.

## 3.9) Summary

The execution of the Service Instruction - PAC must be confirmed in the logbook.



A revision bar outside of the page margin indicates a change to text or graphic.

Translation into other languages might be performed in the course of language localization but does not lie within ROTAX' scope of responsibility.

In any case the original text in English language and the metric units are authoritative.

## 3.10) Inquiries

Inquiries regarding this Service Instruction - PAC should be sent to the ROTAX® Authorized Distributor of your area.

A list of all ROTAX® Authorized Distributors or their independent Service Centers is provided on [www.flyrotax.com](http://www.flyrotax.com).

NOTE: The illustrations in this document show the typical construction. They may not represent full detail or the exact shape of the parts which have the same or similar function. Exploded views are **not technical drawings** and are for reference only. For specific detail, refer to the current documents of the respective engine type.