

Air filter for ROTAX® Aircraft Engines

ATA System: 73-10-00 Intercooler, wastegate

1) Planning information

“PAC” Service Instruction Documents provide detailed information on non-certified ROTAX® Aircraft Engine Parts, Accessories and Clothing. Referenced parts and accessories are provided without EASA certification or ASTM compliance. Certification / Compliance of referenced Parts and Accessories must be completed by the aircraft OEM.

To obtain satisfactory results, procedures specified in this publication must be accomplished with accepted methods in accordance with prevailing legal regulations.

BRP-Rotax GmbH & Co KG cannot accept any responsibility for the quality of work performed in accomplishing the requirements of this publication.

1.1) Applicability

Refer to the latest issue of the relevant Illustrated Parts Catalog:

NOTICE

The air filter may be declared as part of the air intake system on aircraft-side and so might not be a part of the Engine Type Design. Such a PAC part has been then tested and released by BRP-Rotax, but it might not be certified for the relevant engine type.

In such a case the correct function in conjunction with the entire system is the responsibility of the aircraft manufacturer and must be carried out jointly with the aircraft.

1.2) Concurrent ASB/SB/SI and SL

None.

1.3) Reason

In the course of continued development and our commitment to product improvement, changes to air filter parts have been introduced.

1.4) Subject

Air filter for ROTAX® Aircraft Engines.

1.5) Compliance

NONE - For Information Only.

1.6) Approval

None.

1.7) Labor time and credit

Estimated labor hours:

Engine installed in the aircraft - - - labor time will depend on airframe installation and therefore no estimate is available from the engine manufacturer.

1.8) Mass data

Change of weight - - - 0.15 kg (0.33 lb).

Moment of inertia - - - unaffected.

SERVICE INSTRUCTION - PAC

1.9) Electrical load data

No change.

1.10) Software modifications

No change.

1.11) References

In addition to this technical information refer to current issue of

- Operators Manual (OM)
- Illustrated Parts Catalog (IPC)
- Installation Manual (IM)
- Maintenance Manual Line (MML)
- Maintenance Manual Heavy (MMH)

NOTE: The status of the Manuals can be determined by checking the table of amendments. The 1st column of this table shows the revision status. Compare this number to that listed on the ROTAX website: www.flyrotax.com. Updates and current revisions can be downloaded for free.

1.12) Other Publications affected

None.

1.13) Interchangeability of parts

- All parts are interchangeable

SERVICE INSTRUCTION - PAC

2) Material Information

2.1) Material- cost and availability

Price and availability will be provided on request by ROTAX® Authorized Distributors or their independent Service Centers.

2.2) Company support information

- Any possible support by BRP-Rotax will be provided on request by ROTAX® Authorized Distributors or their independent Service Centers.

2.3) Material requirement and credit per engine

Parts requirement:

Fig.no.	Part no.	Qty/ engine	Description	Application
1	825900	1	Air filter	Turbocharger air inlet

2.4) Material requirement and credit per spare part

None.

2.5) Rework of parts

None.

2.6) Special tooling/lubricants- /adhesives- /sealing compounds

Description	Qty/engine	Part no.	Application
Air filter oil (14.8 ml)	1	897870	Air filter

NOTICE

If using special lubricants/compounds, observe the manufacturers specifications.

SERVICE INSTRUCTION - PAC

3) Accomplishment/Instructions

- ROTAX® reserves the right to make any amendments to existing documents, which might become necessary due to this standardization, at the time of next revision or issue.

NOTE: Before maintenance, review the entire documentation to make sure you have a complete understanding of the procedure and requirements.

Accomplishment

All measures must be implemented and confirmed by at least one of the following persons or organizations:

- ROTAX® - Airworthiness representatives
- ROTAX® - Authorized Distributors or their independent Service Centers
- Persons with approved qualifications for the corresponding engine types. Only authorized persons (iRMT, Level Heavy Maintenance) are entitled to carry out this work.

NOTE: All work has to be performed in accordance with the relevant Maintenance Manual.

3.1) Spare Parts - related information



See relevant Illustrated Parts Catalog (IPC) for the respective engine type, Chapter 73-10-00.

Fig. 1. TYPICAL

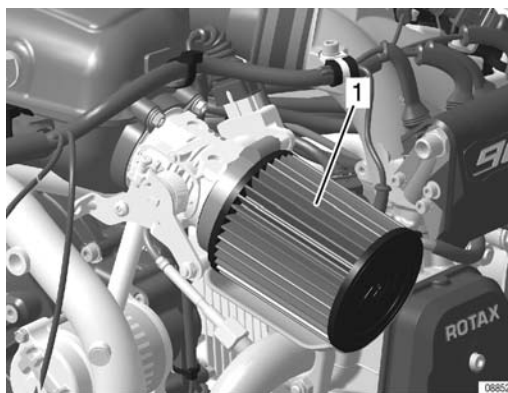

3.2) Installation - related information



Regarding installation of your air filter see also the aircraft manufacturer's instructions.

SERVICE INSTRUCTION - PAC

3.2.1) Technical data

Air filter dimension

Fig. 2

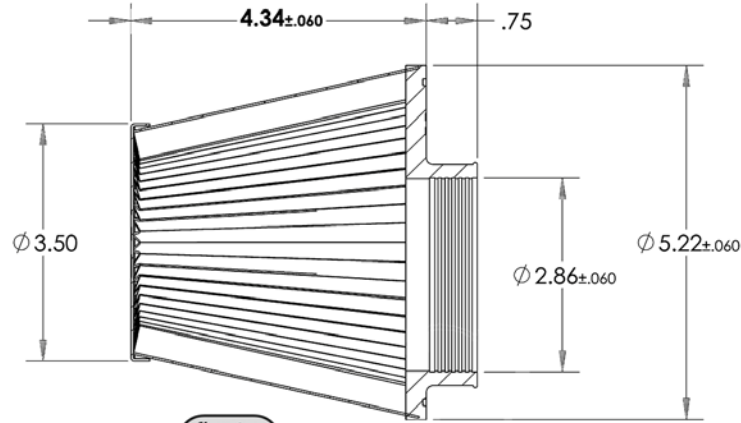

Installation

NOTE: New ROTAX® air filter part no. 825900 is pre-oiled and needs no further preparation before installation.

See Fig. 2.

Step	Procedure
1	Remove new air filter from the packaging and ensure that the inside of the filter is clean and free of foreign objects.
2	Clean and de-grease the air filter mounting flange and clamp area.
3	Place the air filter onto the aircraft's air inlet. Tighten clamp in place.

NOTE: Residual filter oil in the mounting flange area may inhibit secure attachment.

NOTICE

The air filter must be secured by clamp attachment and a wire securing element.

3.3) Operation - related information



Regarding proper operation and checks of your air filter see the aircraft manufacturer's instructions for continued airworthiness.

3.4) Maintenance (Line) - related information

Points of inspection interval operating hours instructions:

NOTICE

In the event of dust formation, clean air filter at correspondingly shorter intervals. If filter mat is damaged, replace air filter.

d06506.fm

SERVICE INSTRUCTION - PAC

Points of inspection	Interval Operating hours		Chapter Reference
	100 h	200 h	
Check for obstruction, cracks, wear and security of attachment.	X(25 h*)		See relevant Maintenance Manual Line (MML) for the respective engine type and its periodical maintenance information. NOTE: Observe the air filter manufacturer's installation instructions and specifications.

*) Flying in deserts or areas with heavily contaminated or dusty air causes increased wear on all components. For this reason, shorter maintenance intervals are recommended.

3.4.1) Cleaning the air filter

NOTICE

Never use gasoline, steam, caustic liquids, strong detergents, particle cleaning agents or high pressure cleaners during this steps.

Cleaning

To clean the dry air filter the following steps are necessary:

See Fig. 6.

Step	Procedure
1	Liberally spray K&N Air Filter Cleaner onto both sides of filter and allow to soak for 10 minutes to loosen deposits. Do not allow cleaner to dry on air filter.
2	Rinse off the air filter with cool low-pressure water applied to the clean side out in order to flush the dirt out of the air filter. Continue to rinse the air filter until all traces of cleaner are gone. It may be necessary to repeat steps 1 and 2.
3	After rinsing your filter, gently shake off the excess water and only allow air filter to dry naturally. Do not apply oil until the air filter is completely dry (6-8 hrs).
4	Apply K&N air filter oil sparingly along the crown of each pleat. Allow the oil to wick for approximately 20 minutes then touch up any light areas on either side of air filter until there is a uniform light pink color at all areas.

Fig. 3. Air filter cleaning procedure.



1. Soak

2. Rinse

3. Dry

4. Oil

3.5) Maintenance (Heavy) - related information

- Restore aircraft to original operating configuration.
- Connect negative terminal of aircraft battery.

d06506.fm

SERVICE INSTRUCTION - PAC

3.6) Test run

In case of uninstalled engines test run can be skipped as this is covered by the mandatory test run after installation.



Conduct test run. See chapter 12-20-00 of the latest Maintenance Manual Line (MML) for the respective engine type.

3.7) Summary

The execution of the Service Instruction - PAC must be confirmed in the logbook.

| A revision bar outside of the page margin indicates a change to text or graphic.

Translation into other languages might be performed in the course of language localization but does not lie within ROTAX® scope of responsibility.

In any case the original text in English language and the metric units are authoritative.

3.8) Inquiries

Inquiries regarding this Service Instruction - PAC should be sent to the ROTAX® Authorized Distributor of your area.

A list of all ROTAX® Authorized Distributors or their independent Service Centers is provided on www.flyrotax.com.

NOTE: The illustrations in this document show the typical construction. They may not represent full detail or the exact shape of the parts which have the same or similar function. Exploded views are **not technical drawings** and are for reference only. For specific detail, refer to the current documents of the respective engine type.