

# Optional fuel pressure adapter for ROTAX® Aircraft Engines

ATA System: 73-10-00 Fuel system

## 1) Planning information

“PAC” Service Instruction Documents provide detailed information on ROTAX® Aircraft Engine Parts and Accessories. Depending on the engine type used with, the referenced parts and accessories may be provided with or without EASA certification or ASTM compliance. Certification / Compliance of referenced Parts and Accessories must in such cases be completed by the aircraft OEM.

To obtain satisfactory results, procedures specified in this publication must be accomplished with accepted methods in accordance with prevailing legal regulations.

BRP-Rotax GmbH & Co KG cannot accept any responsibility for the quality of work performed in accomplishing the requirements of this publication.

### 1.1) Applicability

Refer to the latest issue of the relevant Illustrated Parts Catalog of your specific engine type.

#### **NOTICE**

The optional fuel pressure adapter is not part of the Engine Type Design. Such a PAC part has been then tested and released by BRP-Rotax, but it might not be certified for the relevant engine type.

In such a case the correct function in conjunction with the entire system is the responsibility of the aircraft manufacturer and must be carried out jointly with the aircraft.

### 1.2) Concurrent ASB/SB/SI and SL

In addition to this Service Instruction - PAC the following Service documents must be observed and complied with:

in general all relevant Alert Service Bulletins (ASB), Service Bulletins (SB), Service Instructions (SI), Service Letters (SL), Service Instruction - Parts and Accessories (SI-PAC).

### 1.3) Reason

In the course of continuous development and standardization, an optional fuel pressure adapter has been introduced as an optional extra part.

### 1.4) Subject

Optional fuel pressure adapter for ROTAX® Aircraft Engines.

### 1.5) Compliance

None - For Information Only.

### 1.6) Approval

None.

### 1.7) Labor time

Estimated labor hours:

Engine installed in the aircraft - - - labor time will depend on airframe installation and therefore no estimate is available from the engine manufacturer.

# SERVICE INSTRUCTION - PAC

---

## 1.8) Mass data

Change of weight - - - none.

Moment of inertia - - - unaffected.

## 1.9) Electrical load data

No change.

## 1.10) Software modifications

No change.

## 1.11) References

In addition to this technical information refer to current issue of

- in general Operators Manual (OM)
- in general Illustrated Parts Catalog (IPC)
- in general Installation Manual (IM)
- in general Maintenance Manual Line (MML)
- in general Maintenance Manual Heavy (MMH)

NOTE: The status of the Manuals can be determined by checking the table of amendments. The 1<sup>st</sup> column of this table shows the revision status. Compare this number to the one listed on the ROTAX website:  
[www.flyrotax.com](http://www.flyrotax.com). Updates and current revisions can be downloaded for free.

## 1.12) Other Publications affected

None.

## 1.13) Interchangeability of parts

- All parts are interchangeable

# SERVICE INSTRUCTION - PAC

## 2) Material Information

### 2.1) Material- cost and availability

Price and availability will be provided on request by ROTAX® Authorized Distributors or their independent Service Centers.

### 2.2) Company support information

- Any possible support by BRP-Rotax will be provided on request by ROTAX® Authorized Distributors or their independent Service Centers.

### 2.3) Material requirement per engine

Parts requirement:

Part no.	Qty/ engine	Description	Application
841131	1	Sensor banjo bolt M12x1.5	at fuel pressure regulator
664365*	1	Pressure sensor 10	at fuel pressure regulator
250646	2	Sealing ring A12x18-CU	at fuel pressure regulator

\*or equivalent as required by your avionic system and/or aircraft manufacturer.

### 2.4) Material requirement per spare part

None.

### 2.5) Rework of parts

None.

### 2.6) Special tooling/lubricants- /adhesives- /sealing compounds

None.

# SERVICE INSTRUCTION - PAC

---

## 3) Accomplishment/Instructions

- ROTAX reserves the right to make any amendments to existing documents which might become necessary due to this standardization, at the time of next revision or issue.

NOTE: Before maintenance, review the entire documentation to make sure you have a complete understanding of the procedure and requirements.

### Accomplishment

All measures must be implemented and confirmed by at least one of the following persons or organizations:

- ROTAX® Airworthiness representatives
- ROTAX® - Authorized Distributors or their independent Service Centers
- Persons with approved qualifications for the corresponding engine types. Only authorized persons (iRMT, Level Heavy Maintenance) are entitled to carry out this work.



See current Installation Manual (IM) for the respective engine type.

### General

Further material on general inspection, maintenance and repair can also be found in relevant Advisory Circular AC 43.13 from FAA.

### Advisory Circular

The Advisory Circular (AC) contains maintenance methods, techniques and practices.

# SERVICE INSTRUCTION - PAC

## 3.1) Spare parts - related information



See current Illustrated Parts Catalog (IPC) for the respective engine type.

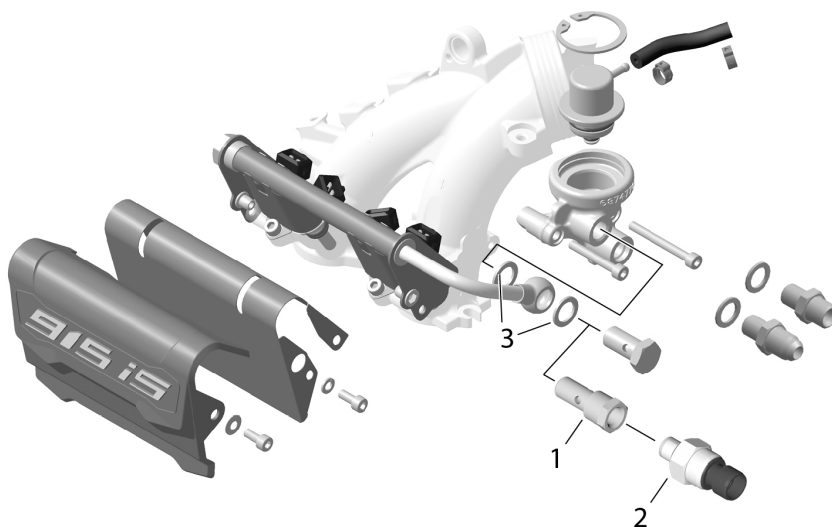

AE 5iS\_0130\_b

Pos.	Description	Part no.
1	Sensor banjo bolt M12x1.5	841131
2	Pressure sensor 10	664365
3	Sealing ring A12x18-CU	250646

## 3.2) Operation - related information



See current Operators Manual (OM) for the respective engine type.

## 3.3) Installation - related information

### General



See current Installation Manual (IM) for the respective engine type.

d06919.fm

# SERVICE INSTRUCTION - PAC

## 3.4) Maintenance (Line) - related information



See current Maintenance Manual Line (MML) for the respective engine type.

Points of inspection	Interval Operating hours	Chapter Reference
	100 h	
Inspect the fuel system on the engine side for leaks.	X	See relevant Maintenance Manual Line (MML) for the respective engine type and its periodical maintenance information.
Inspect the fuel system for damages	X	

## 3.5) Maintenance (Heavy) - related information



See current Maintenance Manual Heavy (MMH) for the respective engine type.



Before opening the fuel injection system, drain the fuel from engine rail. See relevant Maintenance Manual Line Chapter 12-20-00 section Planned maintenance.

**NOTE:** Before accomplishment, review the entire documentation to make sure you have a complete understanding of the procedure and requirements.



If the fuel system has already been installed and pressurized, drain the fuel from engine rail. See relevant Maintenance Manual Line Chapter 12-20-00 section Scheduled maintenance

Step	Procedure
1	Remove the fuel pressure regulator banjo bolt at fuel rail 2/4 and discard sealing rings.

d06919.fm

# SERVICE INSTRUCTION - PAC

- 1. Banjo bolt M12x1.5

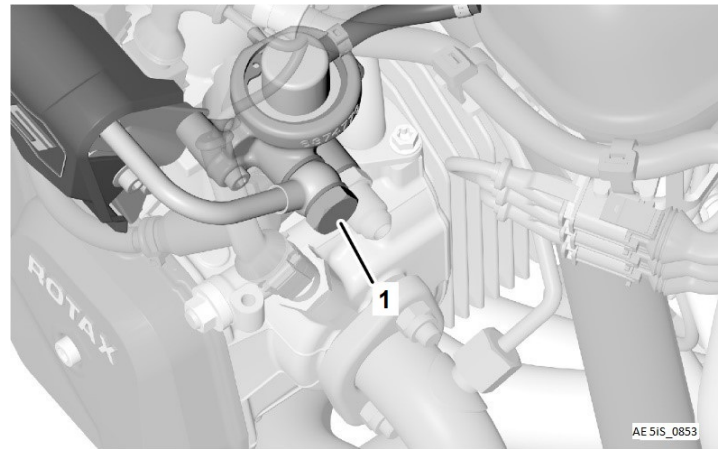

Fig. 1

## **ENVIRONMENTAL NOTE**

Work with the utmost care to ensure that no water pollutants can penetrate into the soil, water or the sewerage system.  
 Dispose of fuel at the respective collecting point or hand it over to an approved disposal company.

Step	Procedure
2	Install and hand-tighten the adapter for fuel pressure sensor with new sealing rings.

- 1. Adapter
- 2. Sealing ring A12

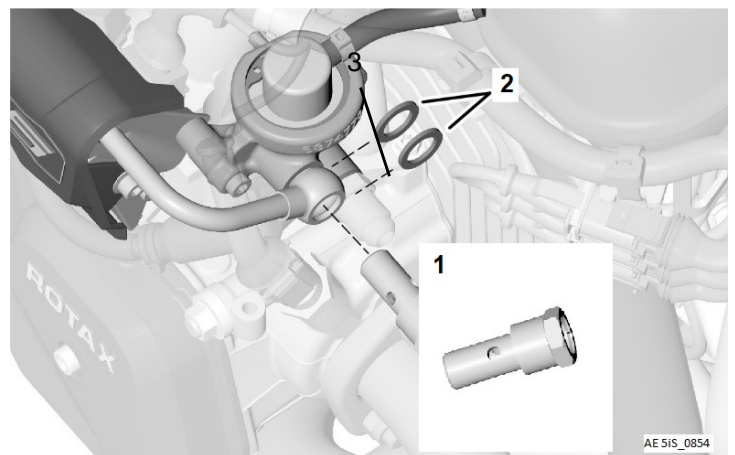

Fig. 2

d06919.fm

# SERVICE INSTRUCTION - PAC

Step	Procedure
3	Torque adapter to 25 Nm (18 ft. lb.).
4	Clean threads of the pressure sensor.
5	Apply LOCTITE 243 to threads of the pressure sensor.
6	Torque sensor into adapter. Tightening torque 15 Nm (133 in. lb.).
7	Connect pressure sensor to instrumentation.

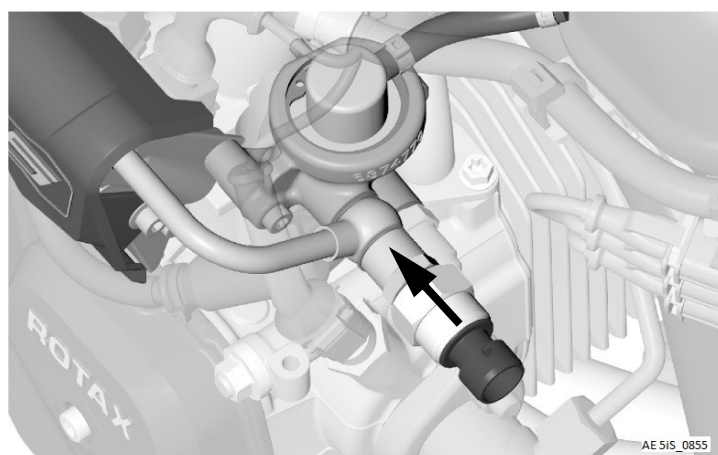

Fig. 3



# SERVICE INSTRUCTION - PAC

---

## 3.6) Finishing work

- Restore aircraft to original operating configuration
- Connect negative terminal of aircraft battery

## 3.7) Test run

In case of uninstalled engines test run can be skipped as this is covered by the mandatory test run after installation.



Conduct test run and perform leakage check.  
See current Maintenance Manual Line (MML) for the respective engine type, Chapter 12-20-00.

## 3.8) Summary

The execution of the Service Instruction - PAC must be confirmed in the logbook.

**|** A revision bar outside of the page margin indicates a change to text or graphic.

Translation into other languages might be performed in the course of language localization but does not lie within ROTAX' scope of responsibility.

In any case the original text in English language and the metric units are authoritative.

## 3.9) Inquiries

Inquiries regarding this Service Instruction - PAC should be sent to the ROTAX® Authorized Distributor of your area.

A list of all ROTAX® Authorized Distributors or their independent Service Centers is provided on <https://dealerlocator.flyrotax.com>.

# SERVICE INSTRUCTION - PAC

## 4) Appendix

The following drawings should convey additional information:

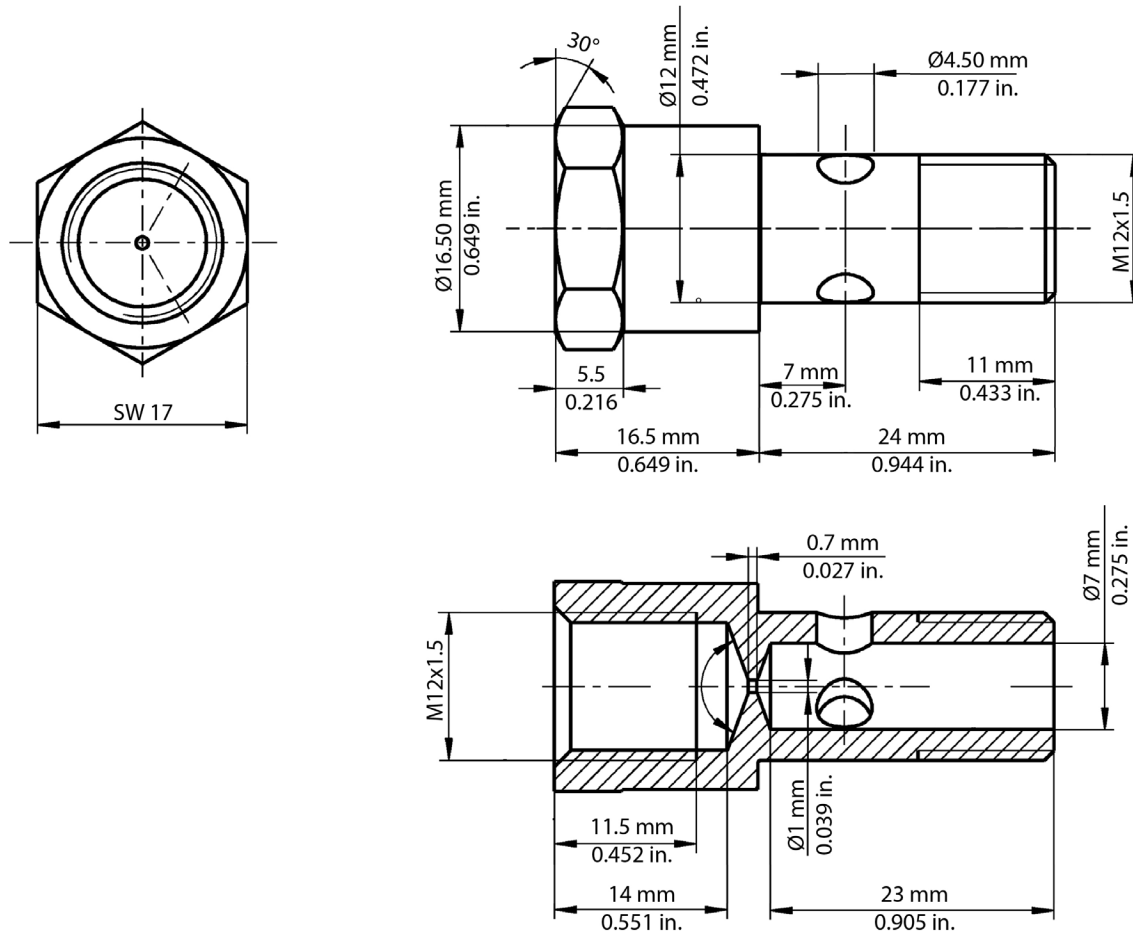

AE\_5iS\_0752\_a

Sensor banjo bolt part no. 841131

Fig. 4